

DEVELOPMENT AND TESTING OF PROTOCOLS FOR EVALUATING EMERGING
TECHNOLOGIES FOR THE TREATMENT OF STORMWATER

by

NOBORU TOGAWA

ROBERT E. PITT, COMMITTEE CHAIR
S. ROCKY DURRANS
DEREK G. WILLIAMSON
KAREN M. BOYKIN
SHIRLEY E. CLARK

A DISSERTATION

Submitted in partial fulfillment of the requirements
for the degree of Doctor of Philosophy
in the Department of Civil, Construction, and Environmental Engineering
in the Graduate School of
The University of Alabama

TUSCALOOSA, ALABAMA

2011

Copyright Noboru Togawa 2011
ALL RIGHTS RESERVED

ABSTRACT

The primary objective of this research is to examine different testing protocols used to evaluate the removal capabilities of small stormwater control devices. The focus of the field research is to examine the different methods that have been used to measure the performance of stormwater control devices. Detailed field evaluations of the Up-Flo[®] Filter, which was, in part, developed by engineers at the University of Alabama through a Small Business Innovative Research (SBIR) grant from the U.S. Environmental Protection Agency, are used to evaluate and compare the different evaluation protocols. Past data from laboratory and pilot-scale tests that examined unit process performance are also used in the examination of the different evaluation protocols. Therefore, different evaluation tests were conducted under many different scales and conditions to determine the expected performance of the Up-Flo[®] Filter. This is a unique opportunity to examine the results of these different tests to compare and determine which results are also reflected during the full-scale observations under actual rain conditions, and to determine the performance insights which were found during the different testing methods.

The evaluation testing is based on the available protocols, including: TAPE, TARP, NJCAT, and ETV, extended to incorporate additional information. The aim of this research is to recommend modifications to these protocols and to develop a more robust testing and evaluation procedure that can be better used under a broad range of conditions, considering scaling issues and uncertainties associated with different testing environments. Even though these tests examined a single technology in detail, it is expected that the insights obtained pertaining to

evaluation protocols would apply to other similar devices (relatively small flow-through systems having limited storage capacity for the treatment of stormwater).

DEDICATION

To my mother *Masako*, my father *Hiroshi*, who sacrificed their today for my tomorrow.

To *Dr. Robert Pitt*, who has given me knowledge, wisdom, and direction in my life.

LIST OF ABBREVIATIONS AND SYMBOLS

<i>μg/L</i>	Microgram per Little
<i>μm</i>	Micrometer
<i>mg/L</i>	Milligram per Little
<i>g/L</i>	Gram per Little
<i>hr/day</i>	Hour per Day
<i>gal/min/ft²</i>	Gallon per Minutes per Square Foot
<i>%</i>	Percentage
<i>ac</i>	Acre
<i>AL</i>	Alabama
<i>ANOVA</i>	Analysis of Variance
<i>ASCE</i>	American Society of Civil Engineers
<i>ASTM</i>	American Society for Testing and Materials
<i>BBA</i>	British Board of Agreement
<i>BMP</i>	Best Management Practice
<i>BOD</i>	Biochemical Oxygen Demand
<i>Cd</i>	Cadmium
<i>COD</i>	Chemical Oxygen Demand
<i>COV</i>	Coefficient of Variation

<i>Cr</i>	Chromium
<i>Cu</i>	Copper
<i>DI water</i>	Distilled water
<i>DQIs</i>	Data Quality Indicators
<i>EPA</i>	Environmental Protection Agency
<i>ETV</i>	Environmental Technology Verification Program
<i>EU</i>	European Union
<i>EWRI</i>	Environmental and Water Resources Institute
<i>ft</i>	Feet
<i>FHWA</i>	Federal Highway Administration
<i>GPM</i>	Gallons per Minute
<i>IDF</i>	Intensity Duration Frequency
<i>L</i>	Little
<i>LSD</i>	Least Significant Difference
<i>m</i>	Meter
<i>MCTT</i>	Multi-Chamber-Treatment-Train
<i>mL</i>	Mill Little
<i>mm</i>	Millimeter
<i>MPN</i>	Most Probable Number
<i>MS4</i>	Municipal Separate Storm Sewer System
<i>NIST</i>	National Institute of Standards
<i>Ni</i>	Nickel
<i>NJCAT</i>	New Jersey Corporative for Advanced Technology

<i>NPDES</i>	National Pollutant Discharge Elimination System
<i>NSF</i>	National Stormwater Foundation
<i>NSQD</i>	National Stormwater Quality Database
<i>NTU</i>	Nephelometric Turbidity Units
<i>ORP</i>	Oxidation Reduction Potential
<i>PAH</i>	Polycyclic Aromatic Hydrocarbons
<i>Pb</i>	Lead
<i>PEF</i>	Performance Expectation Function
<i>PHs</i>	Petroleum Hydrocarbons
<i>PSD</i>	Particle Size Distribution
<i>PSH</i>	Penn State Harrisburg
<i>QA</i>	Quality Assurance
<i>QAPP</i>	Quality Assurance Project Plan
<i>QC</i>	Quality Control
<i>RPD</i>	Relative Percent Difference
<i>RSD</i>	Relative Standard Deviation
<i>SBIR</i>	Small Business Innovative Research
<i>SD</i>	Standard Deviation
<i>SSC</i>	Suspended Solids Concentration
<i>SWMM</i>	Stormwater Management Manual
<i>TAPE</i>	Technology Assessment Protocol – Ecology
<i>TARP</i>	Technology Acceptance Reciprocity Partnership
<i>TDS</i>	Total Dissolved Solids

<i>TMDL</i>	Total Maximum Daily Load
<i>TN</i>	Total Nitrogen
<i>TP</i>	Total Phosphorus
<i>TS</i>	Total Solids
<i>TSS</i>	Total Suspended Solids
<i>WERF</i>	Water Environment Research Foundation
<i>WinSLAMM</i>	Windows Version of Source Loading and Management Model
<i>Zn</i>	Zinc

ACKNOWLEDGEMENTS

I would like to thank my advisor, Dr. Robert Pitt, for his continuous guidance, trust, and support in this research. I would like to thank the remaining members of my committee, Dr. S. Rocky Durrans, Dr. Derek G. Williamson, Dr. Shirley E. Clark, and Dr. Karen M. Boykin, for their assistance and advice during this research.

I would like to thank Dr. Bob Andoh and Mr. Kwabena Osei of Hydro International, Portland, ME for providing financial support to this research. I want to thank my fellow UA graduate students who helped me with various field tests, especially Redahegn Sileshi, Sree Usha, and Brad Wilson. Without your help, we could not complete the field tests. I also thank the City of Tuscaloosa for giving us permission and helping us in conducting the field tests. Special thanks to Tim Ryan, department technician at the University of Alabama who helped us with the field installations. Thank you again for the faculty and staff of the Department of Civil, Construction, and Environmental Engineering for your kind support and concern during my study here.

CONTENTS

ABSTRACT.....	ii
DEDICATION.....	iv
LIST OF ABBREVIATIONS AND SYMBOLS.....	v
ACKNOWLEDGEMENTS.....	ix
LIST OF TABLES.....	xxviii
LIST OF FIGURES.....	xxxii
1: INTRODUCTION.....	1
1.1 Common Stormwater Technology Testing Protocols.....	1
1.2 Protocols Conflicts and Evaluation.....	2
1.3 The need for New Protocols used to Test Emerging Stormwater Technologies.....	4
1.4 Up-Flo [®] Filter Overview.....	5
1.5 Significance of the Study.....	6
1.6 Hypotheses.....	6
1.6.1 Methods and Analyses.....	7

1.7	Objective	10
1.8	Contributions.....	11
2:	LITERATURE REVIEW	12
2.1	Background History for Protocols	12
2.2	Development of Stormwater Treating Protocols	14
2.2.1	Technology Assessment Protocol – Ecology (TAPE).....	15
2.2.2	Technology Acceptance Reciprocity Partnership (TARP).....	15
2.2.3	New Jersey Corporation for Advanced Technology (NJCAT).....	16
2.2.4	Environmental Technology Verification Program (ETV).....	16
2.3	TAPE, TARP, NJCAT, and ETV Comparison.....	17
2.3.1	Applicable States	17
2.3.2	Stormwater Criteria for Sampling.....	18
2.3.3	Sampling Procedure	20
2.3.4	Constituents for Analysis.....	21
2.3.5	Sampling Preservation and Handling.....	24
2.4	Other Protocols for Stormwater Technology Verification.....	25
2.4.1	International BMP Database Protocol	26
2.4.2	International Protocols	27
2.5	Statistical Analyses for Data Presentations.....	27
2.5.1	Numbers of Storms to Monitor	28
2.5.2	Short-Comings Associated with Pollutant Percent Removal Performance Requirements	31

2.5.3	Percentage Reduction and Effluent Quality.....	33
2.5.4	Percent Removal and Particle Size Distribution.....	34
2.5.5	Field Testing Challenges.....	35
2.5.6	TSS Reduction Criterion and/or TP Removal Requirements	36
2.6	Review of the Upflow Filtration Technology	37
2.6.1	Definition and Purpose of Catch Basin.....	38
2.6.2	Geometries of Catch Basins.....	38
2.7	Stormwater Pollutants	41
2.8	Up-Flo [®] Filter Technology Background.....	44
2.8.1	General Technology.....	44
2.8.2	Operation.....	45
2.8.3	Filtration Module	46
2.8.4	Filtration Process	47
3:	METHDOLOGY AND DESCRIPTION OF THE EXPERIMENTS	49
3.1	Introduction.....	49
3.1.1	Project Goals.....	50
3.1.2	Project Objectives	50
3.2	Available Data for the Analysis.....	51
3.3	Design of Experiment	56
3.4	Applicable State Criteria.....	57
3.5	Minimum Storm Event Criteria	58

3.6	Minimum Rain Depth and Storm Duration Criteria	59
3.7	Minimum Number of Subsamples per Event Criterion	60
3.8	Minimum Time Between Event Criterion	61
3.9	Initial Field Sampling	62
3.9.1	Test Location and Land Use	62
3.9.2	Pollutant Sources and Site Maintenance.....	65
3.9.3	Water Quality and Water Resources.....	66
3.9.4	Local Meteorological Conditions	66
3.9.5	Stormwater Treatment Flow Rates	68
3.9.6	Background Water Quality and Pollutants	71
3.10	Installation of Full Scale Filter	76
3.11	Controlled Tests	80
3.11.1	Summary	80
3.11.2	Controlled Flow Test Preparation.....	80
3.11.3	Methodology for the Evaluation of Filtration Rate.....	82
3.11.4	Controlled SSC Removal Tests	84
3.12	Actual Field Monitoring	93
3.12.1	Sampling Location.....	93
3.12.2	Pollutant Constituent Selection.....	94
3.12.3	Phosphorus Testing Procedures	95
3.12.4	Sampling Process (Flow Chart in Figure 30).....	97
3.12.5	Suspended Sediment Concentration (ASTM, 1997).....	101

3.12.6	Dissolved Solids.....	101
3.12.7	Procedure for Suspended Sediment Solids Analysis (Chan, Li, & Stenstrom, 2008; Clark & Pitt, 2008; Clark & Siu, 2008; J. R. Gray, Glysson, Turcios, & Schwarz, 2000).	102
3.12.8	Procedure for Total Dissolved Solids Analysis (Standard Method, 2005).....	103
3.12.9	TSS and SSC Procedures.....	103
3.12.10	Sampling Effort.....	104
3.12.11	Water Quality Data Collection Method.....	105
3.12.12	Monitoring Equipment.....	106
3.12.13	Pre-Sampling Site Hydrology Monitoring and Programming of Automatic Samplers	107
3.12.14	Estimated Total Number of Samples.....	113
3.12.15	Sample Handling.....	114
3.12.16	Sampler Maintenance.....	115
3.12.17	Field Sheet.....	115
3.12.18	Automated Data Recording.....	117
3.12.19	Precipitation Measurements.....	117
3.12.20	Additional Monitoring.....	117
3.12.21	Regulatory Criteria.....	117
3.13	QA/QC Methods.....	118
3.13.1	Data Quality Indicators.....	118
3.13.2	Precision.....	119
3.13.3	Comparability.....	120
3.13.4	Representativeness.....	120

3.13.5	Completeness	121
3.13.6	Field Quality Assurance.....	122
3.13.7	Equipment Maintenance and Calibration.....	123
3.13.8	Laboratory Quality Assurance	123
3.13.9	Quality Control Procedures.....	124
4:	EVALUATION OF RESULTS AND VERIFICATION OF PROTOCOLS.....	127
4.1	Introduction.....	127
4.2	Laboratory Technology Performance under Different Flows and Sediment Characteristics using UpFlow Filter	135
4.2.1	Statistical Variation in Influent vs. Effluent Concentrations for SSC	138
4.2.2	Bama Belle Full-Scale and SBIR II Performance Comparison of UpFlow Filter 140	
4.3	Different Flows and Sediment Characteristics for Controlled Conditions	142
4.3.1	Bama Belle Full-Scale and SBIR II (pilot-scale) Performance for Different Particle Sizes.....	142
4.3.2	Bama Belle Full-Scale and SBIR II (pilot-scale) Performance for Different Flow Rates	150
4.4	Performance Test Comparisons during Actual Storm Conditions Having Varying Flows and Influent Sediment Characteristics	155
4.4.1	Bama Belle Full-Scale and SBIR II (pilot-scale) Particulate Characteristic under Actual Storm Conditions.....	157

4.4.2	BamaBelle Full-Scale and SBIR II Pilot-scale Observations for Other Constituents during Actual Storm Conditions	163
4.5	Treatment Flow Rate Change with Operation of the Technology	171
4.6	Applicable State Criteria Analysis.....	172
4.7	Minimum Storm Event Criteria Analysis	175
4.7.1	Burton and Pitt Formula.....	176
4.7.2	Paired Sample Formula.....	178
4.7.3	Different Variations Formula.....	179
4.7.4	Non-Parametric Sample Size Approach	179
4.7.5	UpFlow Project Example.....	180
4.8	Minimum Rain Depth and Storm Duration Criteria	181
4.9	Requirements for the Minimum Number of Subsamples per Event.....	183
4.10	Minimum Time Between Event Criterion Analysis	188
4.11	Overall Summary Tables of Performance.....	190
5:	PERFORMANCE OF FULL-SCALE UPFLOW FILTER.....	199
5.1	Controlled Test Results.....	199
5.1.1	Sand Media 25 gpm Controlled Flow Test Results	200
5.1.2	Sand Media 75 gpm Controlled Flow Test Results	202
5.1.3	Sand Media 150 gpm Controlled Flow Test Results	204
5.1.4	CPZ Mix™ Media 25 gpm Controlled Flow Test Results	206
5.1.5	CPZ Mix™ Media 75 gpm Controlled Flow Test Results	208

5.1.6	CPZ Mix™ Media 150 gpm Controlled Flow Test Results	210
5.2	Full-Scale Monitoring Results during Rains.....	212
5.2.1	Example Monitoring Results for July 16, 2010 Event.....	212
5.2.2	Actual Monitoring Results for SSC Analysis	217
5.2.3	Influent and Effluent TSS Concentrations Time Series Plots.....	221
5.2.4	Influent and Effluent SSC Concentrations Time Series	223
5.2.5	Influent and Effluent Turbidity Time Series Plots.....	225
5.2.6	Removal Capability Change with Time for SSC.....	227
5.2.7	Removal Capability Change for TDS	228
5.2.8	Continuous Sump Turbidity Monitoring	229
5.2.9	Bypassing Flow Rate Monitoring.....	230
5.2.10	Sump Sediment Analysis	231
6:	EXAMINATION OF EACH PROTOCOL.....	234
6.1	Technology Assessment Protocol – Ecology (TAPE) Protocol Analysis	234
6.1.1	TAPE Criteria Verification for each Sample Event.....	235
6.1.2	TAPE Qualified Events and UpFlow Filter Performance.....	237
6.2	Technology Acceptance Reciprocity Partnership (TARP) Protocol Analysis	245
6.2.1	TARP Criteria Verification for each Sample Event	245
6.2.2	TARP Qualified Events and UpFlow Filter Performance	247
6.3	New Jersey Corporation for Advanced Technology (NJCAT) Protocol Analysis	249
6.4	Environmental Technology Verification Program (ETV) Analysis	249
6.4.1	ETV Criteria Verification for each Sample Event.....	250

6.4.2	ETV Qualified Events and UpFlow Filter Performance.....	251
6.5	Summary	251
6.6	Recommendations and Proposed Protocol Framework	252
7:	QUALITY ASSURANCE PROJECT PLAN AND RESULTS	258
7.1	Data Quality Verification.....	258
7.1.1	Controlled Test Verification	259
7.1.2	Field Test Verification	260
7.2	Analytical Methods Verification.....	265
7.3	Sample Collection Procedure Verification	266
7.4	Completeness Verification for Each Protocol.....	267
7.5	Field and Laboratory Blank Verification	268
8:	CONCLUSIONS AND FINDINGS	272
8.1	Hypothesis #1.....	272
8.2	Hypothesis #2.....	273
8.3	Objective #1	274
8.4	Objective #2	275
8.5	Objective #3	276
9:	RECOMMENDATIONS AND FUTURE RESEARCH NEEDS.....	278
9.1	Recommendations.....	278

9.2	Future Research Subjects.....	279
	REFERENCES	281
	APPENDICES	287
	Appendix A.1: October 9, 2007 Rain Event and Sampling Graphs	288
	Appendix A.2: October 22, 2007 Rain Event and Sampling Graphs	291
	Appendix A.3: November 18, 2007 Rain Event and Sampling Graphs	294
	Appendix A.4: Jan 8, 2008 Rain Event and Sampling Graphs.....	297
	Appendix A.5: Jan 31, 2008 Rain Event and Sampling Graphs.....	300
	Appendix A.6: March 3-4, 2008 Rain Event and Sampling Graphs	302
	Appendix A.7: April 11, 2008 Rain Event and Sampling Graphs.....	303
	Appendix B.1: Kruskal-Wallis Multiple Comparison for the Influent SSC.....	304
	Appendix B.2: Kruskal-Wallis Multiple Comparison for the Effluent SSC	306
	Appendix B.3: Kruskal-Wallis Multiple Comparison for the Full-Scale vs. SBIR II.....	308
	Appendix B.4.a: Kruskal-Wallis Multiple Comparison for the <0.45 μm Solids Concentration.....	310
	Appendix B.4.b: Kruskal-Wallis Multiple Comparison for the 0.45~3 μm Solids Concentration	312
	Appendix B.4.c: Kruskal-Wallis Multiple Comparison for the 3~12 μm Solids Concentration	314

Appendix B.4.d: Kruskal-Wallis Multiple Comparison for the 12~30 μm Solids Concentration	316
Appendix B.4.e: Kruskal-Wallis Multiple Comparison for the 30~60 μm Solids Concentration	318
Appendix B.4.f: Kruskal-Wallis Multiple Comparison for the 60~120 μm Solids Concentration	320
Appendix B.4.g: Kruskal-Wallis Multiple Comparison for the 120~250 μm Solids Concentration	322
Appendix B.4.h: Kruskal-Wallis Multiple Comparison for the >250 μm Solids Concentration	324
Appendix C.1: Kruskal-Wallis Multiple Comparison for the <0.45 μm Solids Concentration	326
Appendix C.2: Kruskal-Wallis Multiple Comparison for the 0.45~3 μm Solids Concentration	328
Appendix C.3: Kruskal-Wallis Multiple Comparison for the 3~12 μm Solids Concentration	330
Appendix C.4: Kruskal-Wallis Multiple Comparison for the 12~30 μm Solids Concentration	332
Appendix C.5: Kruskal-Wallis Multiple Comparison for the 30~60 μm Solids Concentration	334
Appendix C.6: Kruskal-Wallis Multiple Comparison for the 60~120 μm Solids Concentration	336
Appendix D.1: Kruskal-Wallis Multiple Comparison for the Turbidity	338
Appendix D.2: Kruskal-Wallis Multiple Comparison for the COD	340

Appendix D.3: Kruskal-Wallis Multiple Comparison for the Phosphorus.....	342
Appendix D.4: Kruskal-Wallis Multiple Comparison for the Nitrate	344
Appendix D.5: Kruskal-Wallis Multiple Comparison for the Ammonia	346
Appendix D.6: Kruskal-Wallis Multiple Comparison for the E-Coli.....	348
Appendix D.7: Kruskal-Wallis Multiple Comparison for the Enterococci	350
Appendix D.8: Kruskal-Wallis Multiple Comparison for the TSS.....	352
Appendix D.9: Kruskal-Wallis Multiple Comparison for the SSC	354
Appendix E.1: Kruskal-Wallis Multiple Comparison for the TSS	356
Appendix E.2: Kruskal-Wallis Multiple Comparison for the Rain Depth.....	358
Appendix F.1: Kruskal-Wallis Multiple Comparison for the July 16, 2010 Turbidity	360
Appendix F.2: Kruskal-Wallis Multiple Comparison for the September 26, 2010 Turbidity	363
Appendix F.3: Kruskal-Wallis Multiple Comparison for the October 12, 2010 Turbidity	366
Appendix F.4: Kruskal-Wallis Multiple Comparison for the October 25, 2010 Turbidity	369
Appendix F.5: Kruskal-Wallis Multiple Comparison for the December 11, 2010 Turbidity.....	372
Appendix F.6: Kruskal-Wallis Multiple Comparison for the December 25, 2010 Turbidity.....	375
Appendix F.7: Kruskal-Wallis Multiple Comparison for the December 31, 2010 Turbidity.....	378
Appendix F.8: Kruskal-Wallis Multiple Comparison for the January 1, 2011 Turbidity.....	381

Appendix F.9: Kruskal-Wallis Multiple Comparison for the January 10, 2011 Turbidity.....	384
Appendix F.10: Kruskal-Wallis Multiple Comparison for the January 25, 2011 Turbidity.....	387
Appendix F.11: Kruskal-Wallis Multiple Comparison for the April 11, 2011 Turbidity.....	390
Appendix G.1: Sand Media 25gpm TSS Probability Analysis Detail	393
Appendix G.2: Sand Media 25gpm TDS Probability Analysis Detail	395
Appendix G.3: Sand Media 25gpm 0.45-3 μm Probability Analysis Detail	397
Appendix G.4: Sand Media 25gpm 3-12 μm Probability Analysis Detail	399
Appendix G.5: Sand Media 25gpm 12-30 μm Probability Analysis Detail	401
Appendix G.6: Sand Media 25gpm 30-60 μm Probability Analysis Detail	403
Appendix G.7: Sand Media 25gpm 60-120 μm Probability Analysis Detail	405
Appendix G.8: Sand Media 25gpm 120-250 μm Probability Analysis Detail	407
Appendix G.9: Sand Media 25gpm 250-1180 μm Probability Analysis Detail	409
Appendix G.10: Sand Media 25gpm >1180 μm Probability Analysis Detail	411
Appendix G.11: Sand Media 75gpm TSS Probability Analysis Detail.....	413
Appendix G.12: Sand Media 75gpm TDS Probability Analysis Detail	415
Appendix G.13: Sand Media 75gpm 0.45-3 μm Probability Analysis Detail	417
Appendix G.14: Sand Media 75gpm 3-12 μm Probability Analysis Detail	419

Appendix G.15: Sand Media 75gpm 12-30 μm Probability Analysis Detail	421
Appendix G.16: Sand Media 75gpm 30-60 μm Probability Analysis Detail	423
Appendix G.17: Sand Media 75gpm 60-120 μm Probability Analysis Detail	425
Appendix G.18: Sand Media 75gpm 120-250 μm Probability Analysis Detail	427
Appendix G.19: Sand Media 75gpm 250-1180 μm Probability Analysis Detail	429
Appendix G.20: Sand Media 75gpm >1180 μm Probability Analysis Detail	431
Appendix G.21: Sand Media 150gpm TSS Probability Analysis Detail	433
Appendix G.22: Sand Media 150gpm TDS Probability Analysis Detail	435
Appendix G.23: Sand Media 150gpm 0.45-3 μm Probability Analysis Detail	437
Appendix G.24: Sand Media 150gpm 3-12 μm Probability Analysis Detail	439
Appendix G.25: Sand Media 150gpm 12-30 μm Probability Analysis Detail	441
Appendix G.26: Sand Media 150gpm 30-60 μm Probability Analysis Detail	443
Appendix G.27: Sand Media 150gpm 60-120 μm Probability Analysis Detail	445
Appendix G.28: Sand Media 150gpm 120-250 μm Probability Analysis Detail	447
Appendix G.29: Sand Media 150gpm 250-1180 μm Probability Analysis Detail	449
Appendix G.30: Sand Media 150gpm >1180 μm Probability Analysis Detail	451
Appendix G.31: Mixed Media 25gpm TSS Probability Analysis Detail.....	453

Appendix G.32: Mixed Media 25gpm TDS Probability Analysis Detail.....	455
Appendix G.33: Mixed Media 25gpm 0.45-3 μm Probability Analysis Detail.....	457
Appendix G.34: Mixed Media 25gpm 3-12 μm Probability Analysis Detail.....	459
Appendix G.35: Mixed Media 25gpm 12-30 μm Probability Analysis Detail.....	461
Appendix G.36: Mixed Media 25gpm 30-60 μm Probability Analysis Detail.....	463
Appendix G.37: Mixed Media 25gpm 60-120 μm Probability Analysis Detail.....	465
Appendix G.38: Mixed Media 25gpm 120-250 μm Probability Analysis Detail.....	467
Appendix G.39: Mixed Media 25gpm 250-1180 μm Probability Analysis Detail.....	469
Appendix G.40: Mixed Media 25gpm >1180 μm Probability Analysis Detail.....	471
Appendix G.41: Mixed Media 75gpm TSS Probability Analysis Detail.....	473
Appendix G.42: Mixed Media 75gpm TDS Probability Analysis Detail.....	475
Appendix G.43: Mixed Media 75gpm 0.45-3 μm Probability Analysis Detail.....	477
Appendix G.44: Mixed Media 75gpm 3-12 μm Probability Analysis Detail.....	479
Appendix G.45: Mixed Media 75gpm 12-30 μm Probability Analysis Detail.....	481
Appendix G.46: Mixed Media 75gpm 30-60 μm Probability Analysis Detail.....	483
Appendix G.47: Mixed Media 75gpm 60-120 μm Probability Analysis Detail.....	485
Appendix G.48: Mixed Media 75gpm 120-250 μm Probability Analysis Detail.....	487

Appendix G.49: Mixed Media 75gpm 250-1180 μm Probability Analysis Detail.....	489
Appendix G.50: Mixed Media 75gpm >1180 μm Probability Analysis Detail.....	491
Appendix G.51: Mixed Media 150gpm TSS Probability Analysis Detail.....	493
Appendix G.52: Mixed Media 150gpm TDS Probability Analysis Detail.....	495
Appendix G.53: Mixed Media 150gpm 0.45-3 μm Probability Analysis Detail.....	497
Appendix G.54: Mixed Media 150gpm 3-12 μm Probability Analysis Detail.....	499
Appendix G.55: Mixed Media 150gpm 12-30 μm Probability Analysis Detail.....	501
Appendix G.56: Mixed Media 150gpm 30-60 μm Probability Analysis Detail.....	503
Appendix G.57: Mixed Media 150gpm 60-120 μm Probability Analysis Detail.....	505
Appendix G.58: Mixed Media 150gpm 120-250 μm Probability Analysis Detail.....	507
Appendix G.59: Mixed Media 150gpm 250-1180 μm Probability Analysis Detail.....	509
Appendix G.60: Mixed Media 150gpm >1180 μm Probability Analysis Detail.....	511
Appendix H.1: July 16, 2010 Rain Event Analysis	513
Appendix H.2: August 14, 2010 Rain Event Analysis	516
Appendix H.3: August 28, 2010 Rain Event Analysis	519
Appendix H.4: September 26, 2010 Rain Event Analysis.....	522
Appendix H.5: October 12, 2010 Rain Event Analysis.....	525

Appendix H.6: October 25, 2010 Rain Event Analysis	528
Appendix H.7: October 28, 2010 Rain Event Analysis	531
Appendix H.8: November 2, 2010 Rain Event Analysis	534
Appendix H.9: November 3, 2010 Rain Event Analysis	537
Appendix H.10: December 11, 2010 Rain Event Analysis	540
Appendix H.11: December 25, 2010 Rain Event Analysis	543
Appendix H.12: December 31, 2010 Rain Event Analysis	545
Appendix H.13: January 1, 2011 Rain Event Analysis	547
Appendix H.14: January 10, 2011 Rain Event Analysis	549
Appendix H.15: January 25, 2011 Rain Event Analysis	551
Appendix H.16: February 25, 2011 Rain Event Analysis	553
Appendix H.17: March 4, 2011 Rain Event Analysis	555
Appendix H.18: March 28, 2011 Rain Event Analysis	557
Appendix H.19: March 29, 2011 Rain Event Analysis	559
Appendix H.20: April 11, 2011 Rain Event Analysis	561
Appendix I.1: BamaBelle Full-Scale and SBIR II (pilot-scale) Performance for “Low” Flow Rate	563

Appendix I.2: BamaBelle Full-Scale and SBIR II (pilot-scale) Performance for “Medium” Flow Rate	566
Appendix I.3: BamaBelle Full-Scale and SBIR II (pilot-scale) Performance for “High” Flow Rate	569
Appendix J: Logistic Regression Analysis for the TAPE Qualification.....	572

LIST OF TABLES

Table 1. Applicable States for each protocol	17
Table 2. Minimum Number of Events	18
Table 3. Minimum Subsamples per Event.....	19
Table 4. Minimum Storm Depth (inches).....	19
Table 5. Minimum Time Duration (hours).....	20
Table 6. Primary Water Quality Constituent of Protocols.....	23
Table 7. Advanced Water Quality Constituent of Protocols.....	24
Table 8. Testing Procedures.....	25
Table 9. Comparison of BMP Database with Other Major Protocols	26
Table 10. Summary of Selected Stormwater Quality Data included in NSQD, Version 3.0 (Pitt et al., 2008)	43
Table 11. Drainage Area and Land Use.....	65
Table 12. Temperature and Precipitation Summary for Tuscaloosa (National Climatic Data Center, 1994-2010)	67
Table 13. Median Stormwater Quality during Preliminary Bama Belle Site Monitoring	74
Table 14. Analytical Methods and Detection Limits/Ranges	97
Table 15. Rainfall and Runoff Data Collected at Monitoring Site	108
Table 16. Automatic Sampler Programs for Different Expected Rain Event Condition.....	110

Table 17. Required Volume and Storage Time for Physical and Chemical Analysis (Standard Method, 2005).....	114
Table 18. Field Sheet for UpFlow Project	116
Table 19. Current and SBIR I Project Under Actual Storm Event Data Comparison (average concentrations).....	129
Table 20. Full and SBIR II Controlled Test Comparison in “Low” Flow Rate for CPZ Mix™ Media (average concentrations).....	130
Table 21. Full and SBIR II Controlled Test Comparison in “Medium” Flow Rate for CPZ Mix™ Media (average concentrations).....	131
Table 22. Full and SBIR II Controlled Test Comparison in “High” Flow Rate for CPZ Mix™ Media (average concentrations).....	131
Table 23. Full and SBIR II Comparison under Actual Storm Event (average concentrations)..	132
Table 24. Six and Single Module Controlled Test Comparison in “Low” Flow Rate (average concentrations).....	133
Table 25. Six and Single Module Test Comparison in “High” Flow Rate for CPZ Media (average concentrations).....	133
Table 26. Observations of Catchbasin Sump Performance (average concentrations).....	134
Table 27. Laboratory/Controlled Test Summary	136
Table 28. “Low Flow” Nonparametric Test Comparisons for Influent and Effluent Sediment Concentrations	151
Table 29. “Medium Flow” Nonparametric Comparison Tests for Influent and Effluent Sediment Concentrations	152

Table 30. “High Flow” Nonparametric Test for Influent and Effluent Sediment Concentrations	154
Table 31. Summary Table for Storm Events of Full and SBIR II	156
Table 32. Required Sample Sizes for UpFlow Project	180
Table 33. Storm Event Summary for November 2 and 3, 2010	189
Table 34. Overall Performance Summary for <0.45 μm (TDS).....	190
Table 35. Overall Performance Summary for 0.45 to 3 μm	191
Table 36. Overall Performance Summary for 3 to 12 μm	192
Table 37. Overall Performance Summary for 12 to 30 μm	193
Table 38. Overall Performance Summary for 30 to 60 μm	194
Table 39. Overall Performance Summary for 60 to 120 μm	195
Table 40. Overall Performance Summary for 120 to 250 μm	196
Table 41. Overall Performance Summary for >250 μm	197
Table 42. Actual Monitoring SSC Analysis Summary (without Sump Accumulations)	218
Table 43. Summary of Full-Scale UpFlow Filter Actual Storm Monitoring.....	220
Table 44. Calculated Mass Balance of Particulate Solids for Monitoring Period	233
Table 45. TAPE Protocol Criteria.....	235
Table 46. Sample Qualification Verification for TAPE Protocol.....	236
Table 47. Qualified Events and UpFlow Filter Performance Evaluation by TSS	238
Table 48. Qualified Events and UpFlow Filter Performance Evaluation by SSC (excluding sump gross solids samples).....	240
Table 49. All Events: UpFlow Filter Performance Evaluation by SSC (excluding sump gross solids samples).....	242

Table 50. TARP Protocol Criteria	245
Table 51. Monitored Rain Qualification Verification for TARP Protocol	246
Table 52. Overall Monitored Performance of the UpFlow Filter (excluding gross solids captured in the sump).....	248
Table 53. ETV Protocol Criteria.....	249
Table 54. Sample Qualification Verification for ETV Protocol	250
Table 55. Turbidity Duplicate Analysis for Sand Media Controlled Flow Test.....	259
Table 56. Turbidity Duplicate Analysis for Mixed Media Controlled Flow Test	259
Table 57. September 26, 2010 Event Duplicate Analysis Result	262
Table 58. February 25, 2011 Event Duplicate Analysis Result.....	264
Table 59. Analytical Method Used.....	266
Table 60. Completeness for Each Protocol.....	267
Table 61. July 13, 2010 Blank Analysis Result	269
Table 62. December 29, 2010 Blank Analysis Result	270

LIST OF FIGURES

Figure 1. Sample Effort Needed for Paired Testing (Power of 80% and Confidence of 95%) (A. Burton & R. Pitt, 2001).....	30
Figure 2. Lenhart’s Performance Expectation Curve (Lenhart, 2007)	33
Figure 3. Typical Catch Basin Designs in United States and Canada (Lager et al., 1977)	39
Figure 4. Typical Catch Basin Designs in Europe (Lager et al., 1977)	40
Figure 5. Recommended design (Lager et al., 1977).....	41
Figure 6. Up-Flo [®] Filter Component (Hydro International Drawing, 2010).....	45
Figure 7. Filter Module Component (Hydro International Drawing, 2010).....	46
Figure 8. Outlet Module and Filtered Draindown (Hydro International Drawing, 2010)	48
Figure 9. Test Site at the Bama Belle Parking Lot	64
Figure 10. Aerial Map by Microsoft Corporation Bird’s Eye (2010).....	65
Figure 11. IDF Curves for Tuscaloosa (Alabama Rainfall Atlas, S. Rocky Durrans).....	68
Figure 12. Percentage of Annual Flows at Tuscaloosa Test 0.9 ac Impervious Site (Pitt & Khambhammettu, 2006)	70
Figure 13. Treatment Flow Rate and Percentage of Annual Flow Treated for Tuscaloosa, AL, 0.9 acre impervious site (Pitt & Khambhammettu, 2006)	71
Figure 14. January 8, 2008 Stormwater Analysis at Bama Belle Site	73
Figure 15. Construction Pictures (Digging and placement of the filter).....	77

Figure 16. Construction Pictures (Pipe connection and effluent sampling box construction).....	78
Figure 17. Construction Photographs (Inlet Installation and Completion).....	79
Figure 18. Controlled Flow Test Preparation	81
Figure 19. Flow Rate Measurement and Controlled Flow Splitter Setup.....	82
Figure 20. Flow vs. Head Graph for the Mixed Media, showing highly repeatable measurements (total filter surface area: 9 ft ²).....	83
Figure 21. Flow vs. Head Graph for Sand Media (total filter surface area: 9 ft ²)	83
Figure 22. Flow vs. Head Graph for CPZ Media (total filter surface area: 9 ft ²).....	84
Figure 23. PSD for the Four Components	86
Figure 24. PSD for the Mixture used for Flow Test	87
Figure 25. Controlled Sediment Capture Test	89
Figure 26. USGS/Dekaport Teflon [™] Cone Splitter	90
Figure 27. Flow Chart for the Analysis	92
Figure 28. Influent Sample is Collected in the Sample Tray.....	94
Figure 29. Sample Splitting Using Churn Splitter.....	99
Figure 30. Flow Chart for the Field Sample Analysis	100
Figure 31. Multiple Comparisons Chart for Influent SSC Concentration	139
Figure 32. Multiple Comparisons Chart for Effluent SSC Concentration.....	139
Figure 33. Full-Scale vs. SBIR II Comparison of Influent and Effluent.....	141
Figure 34. Multiple Comparison Plots for <0.45 μm (TDS) Solids Concentrations.....	142
Figure 35. Multiple Comparison Plots for 0.45~3 μm Solids Concentrations	143
Figure 36. Multiple Comparison Plots for 3~12 μm Solids Concentrations	144
Figure 37. Multiple Comparison Plots for 12~30 μm Solids Concentrations	145

Figure 38. Multiple Comparison Plots for 30~60 μm Solids Concentration.....	146
Figure 39. Multiple Comparison Plots for 60~120 μm Solids Concentration.....	147
Figure 40. Multiple Comparison Plots for 120~250 μm Solids Concentration.....	148
Figure 41. Multiple Comparison Plots for >250 μm Solids Concentration.....	149
Figure 42. Multiple Comparison Plots for <0.45 μm (TDS) Influent and Effluent Solids Concentrations for Monitored Storms	157
Figure 43. Multiple Comparison Plots for 0.45-3 μm Solids Concentration for Monitored Storms	158
Figure 44. Multiple Comparison Plots for 3-12 μm Solids Concentration for Monitored Storms	159
Figure 45. Multiple Comparison Plots for 12-30 μm Solids Concentration for Monitored Storms	160
Figure 46. Multiple Comparison Plots for 30-60 μm Solids Concentration for Monitored Storms	161
Figure 47. Multiple Comparison Plots for 60-120 μm Solids Concentration for Monitored Storms	162
Figure 48. Multiple Comparison Plots for Turbidity for Monitored Storms	163
Figure 49. Multiple Comparison Plots for COD for Monitored Storms.....	164
Figure 50. Multiple Comparison Plots for Phosphorus for Monitored Storms	165
Figure 51. Multiple Comparison Plots for Nitrates for Monitored Storms.....	166
Figure 52. Multiple Comparison Plots for Ammonia for Monitored Storms	167
Figure 53. Multiple Comparison Plots for E-Coli for Monitored Storms.....	168
Figure 54. Multiple Comparison Plots for Enterococci for Monitored Storms	169

Figure 55. Multiple Comparison Plots for TSS for Monitored Storms	170
Figure 56. Multiple Comparison Plots for SSC for Monitored Storms	171
Figure 57. Flow vs. Head Graph for Full-Scale and SBIR II	172
Figure 58. Multiple Comparison Plots for TSS	174
Figure 59. Multiple Comparison Plots for Rain Depth.....	175
Figure 60. Runoff Volume vs. Rain Depth for Actual and Simulated Data	182
Figure 61. 3D Plots for Volume, Precipitation, and Duration	183
Figure 62. July 16, 2010 Rain Event Graph.....	185
Figure 63. July 16, 2010 Storm Turbidity Data and Subsampling Times	185
Figure 64. July 16, 2010 Storm Turbidity vs. Rain Intensity Graph	186
Figure 65. Multiple Comparisons for the Composite Data and Data from Sondes	187
Figure 66. Storm Event for November 2 and 3, 2010.....	188
Figure 67. Sand Media 25 gpm Controlled Flow Test Results.....	201
Figure 68. Sand Media 75 gpm Controlled Flow Test Results.....	203
Figure 69. Sand Media 150 gpm Controlled Flow Test Results.....	205
Figure 70. CPZ Mix TM Media 25 gpm Controlled Flow Test Results.....	207
Figure 71. CPZ Mix TM Media 75 gpm Controlled Flow Test Results.....	209
Figure 72. CPZ Mix TM Media 150 gpm Controlled Flow Test Results.....	211
Figure 73. July 16, 2010 Rain Event Summary	213
Figure 74. Particle Size Distribution Plot for July 16, 2010 Event.....	214
Figure 75. Cumulative Flow Rate Plot for July 16, 2010 Event.....	215
Figure 76. Flow vs. Stage Graph for July 16, 2010 Event.....	216
Figure 77. Level of Drainage for July 16, 2010 Event	217

Figure 78. Influent and Effluent Concentrations of TSS	221
Figure 79. Probability Plot of Influent and Effluent TSS	222
Figure 80. TSS influent vs. Rain Depth Graph.....	223
Figure 81. Influent and Effluent Concentrations of SSC.....	224
Figure 82. Probability Plot of Influent and Effluent SSC.....	224
Figure 83. SSC influent vs. Rain Depth Graph.....	225
Figure 84. Influent and Effluent Turbidity	226
Figure 85. Probability Plot of Influent and Effluent Turbidity.....	226
Figure 86. Removal Capability Change for SSC.....	227
Figure 87. Removal Capability Change for TDS.....	228
Figure 88. Continues Sump Turbidity Monitoring.....	229
Figure 89. Bypassing Flow Monitoring.....	231
Figure 90. Particle Size Distribution for Sump Material.....	232

CHAPTER 1

1: INTRODUCTION

1.1 Common Stormwater Technology Testing Protocols

There have been many types of proprietary filtration devices developed for the treatment of stormwater runoff over the past few decades as the significance of stormwater discharges has become better understood. Recent focus on the attainment of total maximum daily load (TMDL) requirements of Section 303d of the Clean Water Act, as well as the development of the stormwater regulations of the National Pollutant Discharge Elimination System (NPDES), has further emphasized the regulatory components of stormwater management. As innovative technologies increase, there is a need for standard procedures which can evaluate these applications so that the performance of different devices can be compared on a similar basis. Protocols have been established to attempt to provide a standard method for testing stormwater technologies.

The most common protocols used during current verifications of stormwater technologies in the U.S. include the following: 1) Technology Assessment Protocol – Ecology (TAPE), 2) The Technology Acceptance Reciprocity Partnership (TARP), 3) New Jersey Corporation for Advanced Technology (NJCAT), and 4) Environmental Technology Verification Program (ETV). According to the NJCAT's "A Comprehensive Approach to Stormwater Treatment Technology Verification", NJCAT applies TARP for the verification process, so technically there are three

main testing protocols used with somewhat different criteria for evaluating technologies (NJCAT, 2009).

Different jurisdictions use different protocols. TAPE was developed and is used mainly in Washington State, while NJCAT is the primary protocol for New Jersey. As noted above, New Jersey is using substantially-modified TARP protocols under the NJCAT process. TARP has been adopted, but not necessarily used, in multiple states including California, Massachusetts, Maryland, New Jersey, Pennsylvania, and Virginia. The purpose of the U.S. EPA's ETV program is to provide standardization of testing, however; it has not been widely adopted by the states. In addition, the U.S. EPA's ETV program is also supporting the development of verification systems in other countries, including Canada, the European Union (EU), Japan, Korea, the Nordic countries, and the Philippines. There are other emerging protocols, or international regulations, available for the verification of treatment technologies, especially for special conditions or purposes such as the recommended field protocols developed to support the International BMP Database.

1.2 Protocols Conflicts and Evaluation

In the US, different protocols have been used to evaluate stormwater controls. These were usually developed by local governmental agencies or associations of states in an attempt to measure the performance of different stormwater controls under similar conditions. However, these protocols differ somewhat in several ways. The variety of different testing protocols makes the evaluation and acceptance of emerging stormwater treatment technologies complicated, especially for stormwater controls that may be used in different areas of the country, usually requiring retesting and extra expenses. Testing stormwater controls using all available protocols

can be very costly and causes delays in introducing new devices to the marketplace. The main objective of this research is to evaluate existing protocol components through testing of the upflow filter, and to recommend a comprehensive testing protocol framework suitable for critical source area treatment devices that may be applicable for a wide range of national conditions. Proprietary in-drain treatment technologies are those which these protocols are most suited and are defined by NSF International as “inserts placed in floor or area drains to treat waters entering the drain for contaminant removal” (In-Drain Treatment Technologies, 2001). Features of some critical source areas include large paved areas, heavy vehicular traffic, gas stations, equipment maintenance areas, and storage areas. These critical areas are characterized as having larger amounts of pollutants compared to most land uses in the drainage area.

The most common protocols currently used for evaluating stormwater treatment technologies in the U.S include: 1) Technology Assessment Protocol – Ecology (TAPE), 2) The Technology Acceptance Reciprocity Partnership (TARP), 3) New Jersey Corporation for Advanced Technology (NJCAT), and 4) Environmental Technology Verification Program (ETV). There are similarities in each protocol, but they apply slightly different criteria. The protocols were examined as part of this research, specifically as how they apply to a typical stormwater control device. Historical and new data were available for this device collected under different conditions and scales. These were enable the effects of the different criteria (such as storm event sizes and numbers of samples) and scaling issues (such as laboratory vs. field testing) to be identified and quantified. Early bench-scale and pilot-scale test results of upflow filtration processes could be compared to the results of the on-going full-scale tests in order to identify scaling issues associated with small, medium, and large physical tests and uncertainties associated with different testing environments.

1.3 The need for New Protocols used to Test Emerging Stormwater Technologies

Many new stormwater control technologies are proposed and receive preliminary evaluations, but most of these devices have failed to gain their desired result when more in-depth evaluations are conducted. One very common problem is a lack of understanding of the range of flows that need to be treated, resulting in under-sized devices having insufficient treatment capacity. Also, many are designed to treat only a small subset of the many stormwater pollutants (such as relatively large particulates) and they are not capable of handling the large amounts of debris and floatable materials typically existing in the stormwater that can easily clog the device.

Sand and other media filters, such as those developed in Delaware and in Texas, Austin, have been found to be effective for the removal of sediments and associated particulate pollutants. However, these down-flow filters have relatively low treatment flow rates and require large areas to treat runoff from typical source areas. Typical down-flow filters can clog easily, depending on the nature of the water being treated, and require frequent maintenance. Once a filter is clogged, future flows are bypassed without receiving any treatment (Urbonas, 1999).

Initial lab tests using upflow filtration for stormwater treatment had promising results (Clark, 2000). During the SBIR 1 tests, Gill (2004) and Pratap (2004) further conducted column laboratory tests and showed that the upflow columns provided a much greater treatment flow rate compared to down-flow filter columns. The clogging of the media was also reduced during upflow filtration.

Pilot-scale field tests of the upflow stormwater filter were conducted by Khambhammettu (2006) as part of the Phase II project of the US EPA's Small Business Innovative Research (SBIR) program. The prototype of the commercialized upflow filter had maximum treatment flow rates of about 25 GPM per square foot of filter area with about 20 inches of head. The filter

performance tests indicated 70 to 99% reductions of sediments during both controlled and actual storm event monitoring, as well as 70 to 90% reductions of common stormwater pollutants for a broad range of influent conditions (Khambhammettu, 2006)

Protocols must, therefore, be capable of examining a variety of stormwater treatment unit processes under a range of scales and flow rates. The main objective of a protocol is to predict performance under full-scale, real-world runoff conditions. A desirable protocol would enable the cost-effective testing of a lab-scale device and reasonably predict its long-term field performance. Full-scale testing is also needed in order to both verify the protocols and to examine the performance under highly variable conditions.

1.4 Up-Flo[®] Filter Overview

The Up-Flo[®] Filter is a recently developed high-rate stormwater filtration technology that includes a range of complementary unit treatment processes. Compared with traditional downflow filtration, the upflow filtration method reduces clogging problems and can treat stormwater at a much rate. The Up-Flo[®] Filter was developed to remove a broad range of stormwater pollutants, especially those associated with particulates, including: trash, sediments, nutrients, metals, and hydrocarbons. The high treatment flow rate capacities of the Up-Flo[®] Filter are accomplished through controlled fluidization of the filtration media, while still capturing very small particulates through a flexible, but constraining, media container. The Up-Flo[®] Filter also drains down between rain events which minimizes anaerobic conditions in the media and which also partially flushes captured particulates from the media to the storage sump, decreasing clogging and increasing run times between required maintenance events. Gross floatables are

captured through the use of an angled screen before the media and the sump captures bed load particulates.

1.5 Significance of the Study

Stormwater is recognized as a significant source of contamination of many receiving waters. New regulations are requiring the use of stormwater controls, and new controls are continuously being brought to the marketplace. However, many of these new stormwater control devices have not been extensively tested due to cost and time requirements, and have relied on simple evaluations that have often been misleading. The main purpose of the protocols is providing a consistent method for evaluating stormwater technologies and identifying those that will best meet the needs of specific treatment objectives. Currently, there are four main protocols in the U.S. being used depending on the local regulations. If the main objective of a protocol is improving the efficiency of the verification process, the different and conflicting protocols do not support this goal and make this assessment process complicated. Testing with all available protocols require extra costs and times. A single comprehensive protocol framework is therefore desired, especially one that can be applied nationwide.

1.6 Hypotheses

This project addressed the following hypotheses:

1. The development of a single testing and evaluation protocol framework is possible, based on, and improving, components of existing protocols. This framework is especially needed for critical source area treatment devices used in small drainage areas.

2. This single protocol framework can be used to relate pilot-scale to full-scale tests; and controlled tests to actual event tests. The benefits from different protocol components can be tested and verified by laboratory and field tests.

1.6.1 *Methods and Analyses*

In order to test the hypotheses, the following methods and analyses were performed:

- Comparison of Existing Protocols (Chapter 2):
 - Examining and comparing the existing protocols were the first research task of this dissertation research. Literature reviews had identified several different protocols currently used in the assessment process. The main U.S. protocols, TAPE, TARP, NJCAT, and ETV were evaluated to identify similarities and differences.
- Data from Different Experimental Scales (Chapter 4):
 - Data was examined from experiments conducted at different scales, and in different manners for the same basic control practice. This could the effects of scaling to be identified and quantified. Early bench-scale and pilot-scale test results of upflow filtration processes were available from several prior research projects (Khambhammettu, 2006; Penn State Harrisburg, 2007; Pitt & Khambhammettu, 2006; Pratap, 2004). These data were compared to the results of the full-scale tests to identify scaling issues associated with small, medium, and large physical tests. In addition, the field tests that were conducted during this research were included both controlled and actual rain event tests for comparisons of performance results using these two common testing methods that examine steady-state vs. highly variable hydraulic conditions. In addition, high resolution sampling data was compared with single composite data. High resolution sample data was collected in the prototype

phase using separate bottle sampling and analysis, and data were also obtained using water quality sondes during past and current research. Composite data was available from the current full-scale tests, and calculated from the past data, and were used to determine the value of the more abundant data obtained during individual events from the sonde data.

- Full-scale Field Experimentation (Chapter 3 and Chapter 5):
 - A full-scale upflow filtration device was installed at the Riverwalk parking lot near the Bama Belle excursion boat dock on the Black Warrior River in Tuscaloosa, Alabama. Detailed test location and land use were described in Section 3.9.1. The first series of flow tests was conducted for the purpose of determining the hydraulic capacity and the pollutant removal capabilities in a full-scale field installation under controlled conditions. In these tests, the filtration rate of the CPZ MixTM filter media, a proprietary mixture of bone char activated carbon, peat moss, and manganese coated zeolite, was evaluated. Based on results of prior lab scale testing, this mixed media was expected to have high pollutant removal at relatively high treatment flow rates. The Up-Flo[®] Filter was fitted with two stacked media bags in each of the 6 chambers, for a total of 12 bags, as well as the flow distribution material placed above and below the media bags. The maximum treatment flow rate of this configuration was measured to be between 100 and 150 gpm before the filter partially bypasses higher flows.
 - The Up-Flo[®] Filter removal capacity of pollutants were tested during actual rain events and examined sediment, particle sizes, metals, nutrients, and bacteria.

- Sampling at the influent and effluent locations were conducted using two ISCO 6712 automatic samplers and the flow rates and level of the water were measured using an ISCO 4250 area-velocity meter. Another ISCO 4250 area-velocity meter was situated in the main sedimentation chamber to continuously monitor water depths. All the sampling equipments were calibrated during the controlled flow tests.
- The rainfall intensity and depth were measured using a standard tipping bucket rain gauge (ISCO 674), as well as a small totalizing rain gauge for rainfall verification. The main sampling location was located close to moderate sized trees, and the main rain gage was likely affected by their presence. This rain gauge was mainly used to trigger the automatic samplers, and accurate rain data was not expected from this device. We also operated another tipping bucket rain gauge on the roof of the Civil Engineering building on campus 1.75 miles away. In addition, small manual totalizing rain gages were located in the small drainage area to measure the rainfall pattern at the test site. The continuously recorded runoff flow rate was the primary hydraulic parameter affecting the performance of the upflow filter and was periodically calibrated during the test period.
- YSI 6600 water quality sondes were also be used to measure high-resolution (every 5 to 15 minute measurements) water quality data for temperature, dissolved oxygen, pH, ORP, turbidity, conductivity, and water depth. The sondes were installed in the sampling trays at the influent to the Up-Flo[®] Filter and in the outlet sampling box. After the samples had been retrieved for delivery to the laboratory, the sampling tray was emptied into the filter sump and the influent sonde was moved into a perforated

pipe in the filter sump to continuously measure water quality between events in the standing water.

- Statistical Analysis (Chapter 4 and Chapter 5):
 - A number of statistical analyses were used to evaluate the performance data. Paired non-parametric statistical tests, such as the Kruskal-Wallis and the Mann-Whitney-Wilcoxon Test, were used to determine the statistical significance of the differences between the influent and the effluent pollutant concentrations. Numerous graphical analyses of the data were also be conducted, especially for the numerous particle size groupings. Regression analyses, with ANOVA and residual analyses were used to create simple performance models.
- Verification of Protocols (Chapter 6):
 - Protocols were evaluated for possible modification and for guidance for merging protocols. Detailed analyses for the same unit process (upflow filtration) were available from different scales and test protocols. The results of these different evaluations were compared to highlight knowledge gained and conclusions were transferable across these protocol methods. A final composite protocol were then proposed.

1.7 Objective

The objectives of this research were as follows:

- Verify existing protocols and establish guidance to create a protocol framework useful under a wide range of conditions and scales for in-drain treatment technologies.

- Verify that the upflow filtration process is a suitable in-drain treatment technology for stormwater treatment under a wide range of site and hydraulic conditions.
- Verification of the Up-Flo[®] Filter in actual full-scale operation and determine the expected treatability of the device following the different protocols and the proposed protocol framework.

1.8 Contributions

The significant contributions of this research were as follows:

- Contribute to the improvement of existing evaluation protocols and develop a new protocol framework for evaluating stormwater control practices.
- Quantify the benefits of upflow filtration as an effective stormwater control practice that is applicable under a wide range of discharges and contaminants.

CHAPTER 2

2: LITERATURE REVIEW

2.1 Background History for Protocols

Point source discharges, mostly sewage and industrial wastewaters, have been regulated as part of the National Pollutant Discharge Elimination System (NPDES) incorporated with the Clean Water Act of 1972. After 15 years, in 1987, the Clean Water Act was further amended to establish regulations for the control of stormwater, especially stormwater discharges associated with industrial activities and construction sites. Although stormwater has long been regarded as a major source of pollution to urban receiving waters, policymakers have only started to regulate these problems in recent years. According to EPA (2006), 42% of the U.S. stream miles are in poor condition, 25% are in fair condition, and 28% are in good condition. The EPA also reported that the most widespread pollutant problems across the country were associated with nitrogen, phosphorus, and sediments, which are common pollutants in stormwater (EPA, 2006).

Stormwater is a documented major source of these (and other pollutants) in receiving waters near urban centers and in coastal areas. Stormwater quality management may be a relatively new topic in the U.S., but the human history of managing stormwater flows dates back more than 5,000 years. Some notable ancient wastewater drainage systems were researched by Gray (1940), including the Mesopotamian Empires of Assyria, Babylonia from around 2500 B.C. Excavations

exposed sewers constructed of brick, with laterals connected to water-flashed latrines in the houses.

Another example of notable historical significance is the drainage system excavated in the Indus civilization in the area of Mohenjo-Daro, which in Sindi means “The Place of the Dead.” According to Webster (1962), they had well-built chalcolithic houses, baths, and drainage systems built of bricks. He also notes that there were at least nine phases of rebuilding in the city’s history from about 3300 B.C. to about 2700 B.C. Gray (1940) also described another ancient and very remarkable civilization that was established about 3000-1000 B.C, the Palace of Minos near Knossus on the Island of Crete. In particular, he described the Middle Minoan Period, dated about 1900-1700 B.C., when a system of stone drains were built which carried sewage, roof runoff, and general drainage.

There are many other notable historical drainage systems that have been developed over the centuries. Steven and Findlay (2002) summarized unique urban drainage techniques from around 3000 BC to the twentieth century. They also describe changes in public perspective of urban drainage as it was originally viewed as a convenient waste disposal system to becoming a vital component of a sustainable urban system (Burian & Edwards, 2002).

It is clear that wastewater drainage systems have been used since the early history of human civilization, however; mediaeval and some recent western countries had far less developed sewage systems than those ancient cities. Webster (1962) described the earlier drainage systems in Europe which were mainly designed for stormwater and were also used for flushing the streets of dumped chamber pot contents. In London excreta was not legally allowed to be discharged to the storm drainage systems until 1815, until 1833 in Boston, and until as late

as 1880 in Paris (Webster, 1962). Poor sanitary conditions in many large cities resulted in the great cholera epidemics in nineteenth century Europe.

Struggles in the past related to public health and safety, including tragedies in waste and stormwater drainage, lead to rapid developments of treatment technologies since the early years of the 20th century. As many technological applications were developed in a short period, there is a correspondingly large demand to carry out verification processes in a consistent and objective manner to ensure the satisfactory performance and comparability of the new technologies. To satisfy these needs, federal agencies and local governments have created protocols to verify new technologies. However, as markets for the technologies expand from the local to the national level, different protocols created in different areas become an obstacle for their efficient applications. Different and conflicting protocols are confusing and require extra costs to satisfy all the protocols requirements. Therefore, the establishment of a single, unifying protocol is highly desirable.

2.2 Development of Stormwater Treating Protocols

Stormwater treatment protocols have been developed to provide a consistent methodology to test emerging technologies. In the current verification environment in the U.S., four different protocols are applied for evaluating new applications, including: TAPE, TARP, NJCAT, and ETV. NJCAT is mostly based on the TARP protocol. The following section briefly describes each of these protocols.

2.2.1 *Technology Assessment Protocol – Ecology (TAPE)*

The TAPE protocol was developed as part of the Stormwater Management Manual (SWMM) for Western Washington, published by the Washington Department of Ecology in 2001 (Ecology, 2001). Volume V, Chapter 12 of the SWMM describes emerging applications; it does not provide any criteria for the selection and sizing of new technologies. As technologies are rapidly changing, detailed information is not included in the manual. Ecology's basic criteria for an acceptable technology is to achieve a removal goal of 80% for total suspended solids (TSS) for influent concentrations that are greater than 100 mg/L and less than 200 mg/L. For influent TSS concentrations greater than 200 mg/L, a higher treatment goal is set, and for influent concentrations less than 100 mg/L, the facilities are intended to achieve an effluent TSS of 20 mg/L, or less. For the fine particles in the TSS fraction (less than 50 micron mean size), Ecology established a goal of a 50% removal rate for concentrations greater than 100 mg/L and less than 200 mg/L or maximum effluent concentrations of 50 mg/L for influent concentrations less than 100 mg/L (Ecology, 2001). The TAPE protocol was created for local governments in the State of Washington in order to provide guidance for evaluating and accepting new treatment applications. The TAPE protocol also describes removal goals for dissolved metals, phosphorus, and oil and grease for enhanced treatment (TAPE, 2002). TAPE is currently being reviewed for possible changes and updates.

2.2.2 *Technology Acceptance Reciprocity Partnership (TARP)*

The TARP protocol was developed for the purpose of evaluating both structural and nonstructural stormwater control practices. This protocol (2001) is primarily used for controls that are designed for the following purposes: 1) directing and distributing flows; 2) reducing erosive velocities; and 3) removing contaminants such as suspended or dissolved pollutants from

collected stormwater through physical and chemical processes such as settling, media-filtering, ion-exchange, carbon adsorption, and precipitation (TARP, 2001). The states that signed on to this protocol include California, Massachusetts, Maryland, New Jersey, Pennsylvania, and Virginia. As New Jersey is one of the partners of TARP, TARP is used as the foundation for the current NJCAT protocol (Section 2.2.3).

2.2.3 *New Jersey Corporation for Advanced Technology (NJCAT)*

NJCAT is a non-profit membership organization and was created for promoting the retention and growth of technology-based businesses in emerging environmental and energy fields in New Jersey (NJCAT, 2009). NJCAT (2009) is specially focused on the following areas: 1) advance policy strategies and regulatory mechanisms to promote technology commercialization, 2) identify, evaluate, and recommend specific technologies for which the regulatory and commercialization process should be facilitated, 3) establish relationships/alliances to bring new technologies to market and new business to the state, and 4) assist in the identification of markets and applications for commercialized technologies (NJCAT, 2009). For stormwater technologies, NJCAT requires innovative technologies to be tested and verified using the TARP protocol.

2.2.4 *Environmental Technology Verification Program (ETV)*

ETV was developed to describe requirements and guidelines for verifying the performance of new stormwater treatment applications. ETV (2002) is directed by the Wet Weather Flow Technologies program of the US EPA National Risk Management Research Laboratory, Urban Watershed Management Branch, in Edison, NJ, and its verification partner, NSF International (ETV, 2002). NSF International develops standards, provides educational

services for public health, and offers conformity assessment services as a third-party reviewer (ETV, 2002).

2.3 TAPE, TARP, NJCAT, and ETV Comparison

Each protocol has different requirements in evaluating stormwater treatment technologies, as described in the following section.

2.3.1 *Applicable States*

Table 1 shows the jurisdictions that are using the different protocols. As noted previously, New Jersey is using the TARP protocols under the NJCAT process. In addition to the U.S., the EPA’s ETV program is supporting the development of verification systems in other countries, including Canada, the European Union (EU), Japan, Korea, the Nordic countries, and the Philippines.

Table 1. Applicable States for each protocol

TAPE	TARP	NJCAT	ETV
Washington	California Massachusetts Maryland New Jersey Pennsylvania Virginia	New Jersey	U.S. and several other countries

2.3.2 Stormwater Criteria for Sampling

2.3.2.1 Minimum Number of Events

The minimum number of storms to be monitored varies for each protocol. TAPE requires the monitoring of 12 to 35 rain events, depending on the statistical variability of the constituent of concern (TAPE, 2002). TARP requires that the sample should represent the storm events in the climatic region and the sum of the monitored rain depths must be at least 50% of the total annual rainfall (TARP, 2001). ETV necessitates recording all events of precipitation and flow measurement that occur during the study period regardless of the other criteria (ETV, 2002). Table 2 indicates the minimum number of events in each protocol.

Table 2. Minimum Number of Events

TAPE	TARP	ETV
12-35	15-20	15

2.3.2.2 Minimum Number of Subsamples per Event

Each protocol defines different requirements for the minimum number of subsamples per event. TAPE requires the collection of subsamples over the entire runoff period and the composite samples should cover at least 75% of each storm's total runoff volume, up to the design storm volume (TAPE, 2002). TARP requires a minimum of 10 water quality subsamples per storm event and requires a minimum of 5 subsamples for each composite sample (TARP, 2001). ETV requires that each composite sample should be composed of a minimum of five subsamples including at least two subsamples on the rising limb of the runoff hydrograph, at

least one subsample neat the peak, and at least two subsamples on the falling limb of the runoff hydrograph (ETV, 2002). Table 3 shows the minimum numbers of subsamples per event for each protocol.

Table 3. Minimum Subsamples per Event

TAPE	TARP	ETV
10	5-10	5

2.3.2.3 Minimum Storm Depth, Intensity, Duration

Each protocol has slightly different requirements for minimum storm depth. There are no specific requirements for minimum rainfall intensities for the event for the protocols, however; TAPE requires the shortest acceptable runoff duration of 1 hour (TAPE, 2002). Table 4 shows the minimum storm depth for each protocol.

Table 4. Minimum Storm Depth (inches)

TAPE	TARP	ETV
0.15	0.1	0.2

2.3.2.4 Storm Start/End Periods

All protocols require a minimum of six hours between qualified sampling events. Thus, there should be a minimum of six hours between the termination of measured effluent samples

during one event and the start of measured influent samples for the next event. TAPE also requires 6 hours minimum with less than 0.04 inches of rain (TAPE, 2002).

Table 5. Minimum Time Duration (hours)

TAPE	TARP	ETV
6	6	6

2.3.3 *Sampling Procedure*

2.3.3.1 Composite Sampling Method

All of the protocols require the use of programmable automatic water samplers with continuous flow measurements, unless automatic sampling is not feasible. Grab sampling can be used only for parameters which require manual sampling (such as for bacteria). TAPE further includes detailed descriptions for 1) Automatic flow-weighted composite sampling 2) Discrete flow composite sampling, and 3) Combination sampling. All three sampling methods are used to determine whether the treatment technology meets Ecology’s 80% TSS removal on an average annual basis goal (TAPE, 2002). TARP protocol specifically notes that time-weighted composite samples are not acceptable, unless flow is monitored and the event mean concentration can be calculated from the data (TARP, 2001).

2.3.3.2 Sampling Location Requirements

The TAPE protocol requires a site diagram showing all monitoring locations and identify the location of equipment (TAPE, 2002). TARP requires more detailed information about the site including all buildings, land uses, storm drain inlets, and other control devices as well as

description of the site drainage area, percent impervious area, percent of the area directly connected to the treatment technology, description of the path of runoff to the technology, type of activities conducted, pollutant sources, soil type, geological and hydrological conditions, existing control structures, and a site drainage plan (TARP, 2001). In contrast, ETV simply states that the location should maximize the mixing of the flow for sampling; there is no other criteria mentioned in the protocol (ETV, 2002).

2.3.3.3 Influent and Effluent Sampling Location

Each protocol contains slightly different criteria for the locations to be used for collecting influent and effluent samples. The TAPE protocol requires influent sampling locations to be a pipe that conveys the total influent to the unit and the effluent sample point should represent the treated effluent (TAPE, 2002). The TARP protocol states that the influent location to be directly upstream of the system and before the flow is split between the treatment system and any bypass. Also, the effluent sampling location needs to be directly downstream of the treated flow and after the effluent joins the bypass flows (TARP, 2001). ETV requires that the influent sampling location to be as close as possible to the inlet of the treatment device, preferably from a pipe that conveys the total influent to the unit. Effluent samples are to be collected at a location that captures the total treated effluent from the device and if there is a bypass, effluent samples must be taken downstream of the flow recombined point (ETV, 2002).

2.3.4 *Constituents for Analysis*

Target constituents are defined in each protocol, as shown in Table 6 (primary) and Table 7 (advanced). The primary constituent for TAPE is only TSS. TARP requires TSS and SSC as a minimum analysis and recommends other parameters as a support of performance claims. ETV's

criteria are much more flexible and requires reduction of at least one of the pollutants in the five categories such as sediments, nutrients, metals, petroleum hydrocarbons, and bacteria. Advanced constituents listed in each protocol include sediments, nutrients, metals, petroleum hydrocarbons, bacteria, and other categories. Each protocol has slightly different pollutants required for analysis in those specific categories. For the metal analyses, TAPE and ETV have the same constituents, but TARP also lists nickel. The TAPE protocol does not have a requirement for bacteria analysis, but it does lists toxicity. Only the ETV protocol requires turbidity which can be used as a reference for sediment analysis (ETV, 2002; NJCAT, 2009; TAPE, 2002; TARP, 2001).

Table 6. Primary Water Quality Constituent of Protocols

	TAPE	TARP	ETV ¹⁾
Sediments	TSS	TSS SSC	At least one type of sediment test, if no other constituent analyzed including: nutrients, metals, PHs, bacteria
Nutrients			At least one type of nutrients test, if no other constituent analyzed including: sediments, metals, PHs, bacteria
Metals			At least one type of metals test, if no other constituent analyzed including: sediments, nutrients, PHs, bacteria
Petroleum Hydrocarbons			At least one type of PHs test, if no other constituent analyzed including: sediments, nutrients, metals, bacteria
Bacteria			At least one type of bacteria test, if no other constituent analyzed including: sediments, nutrients, metals, PHs ²⁾

1) ETV's primary goal is at least one type of test in five pollutant categories above

2) PHs are petroleum hydrocarbons

Table 7. Advanced Water Quality Constituent of Protocols

	TAPE	TARP	ETV
Sediments	TSS	TSS TDS SSC	TSS SSC
Nutrients	TP	TKN TN TP & DP NO ₃ -N NO ₂ -N Ammonium	TP DP TKN NO ₃ -N NO ₂ -N
Metals	Cd Cu Pb Zn	Ni Cu Pb Zn Cr Cd	Cd Cu Pb Zn
Petroleum Hydrocarbons	PH	TPH PAHs Oil & Grease	TPH PAHs
Bacteria	N.A.	E. coli Total Coliform Enterococci	Fecal Coliform E. coli Enterococci
Other	Toxicity	COD BOD pH Conductivity Temperature	COD BOD Turbidity pH Conductivity Temperature

2.3.5 Sampling Preservation and Handling

Each protocol lists somewhat different lab procedures. ASTM Methods or Standard Methods (Standard Method, 2005) are the most common. Different laboratory procedures can result in different results, especially for TSS vs. SSC, so consistent updated methods are necessary.

Table 8. Testing Procedures

TAPE	TARP	ETV
Ecology method		US EPA method
US EPA method	ASTM methods	<i>Standard Methods</i>
<i>Standard Methods</i>		ASTM method

2.4 Other Protocols for Stormwater Technology Verification

The four main protocols used in the US were described in the previous sections. There are other emerging protocols, or international regulations, available for the verification of technology, especially for special conditions or purposes. Other than full-scale test protocols described above, there are requirements for laboratory-scale evaluations.

The Wisconsin Department of Natural Resources (WIDNR) established an evaluation standard for sedimentation devices. The standard consists of four separate sections including the technical standard, criteria for modeling, laboratory testing criteria, and standard method for using a Coulter Counter to quantify small sediment particles under laboratory-scale testing (Wisconsin Standard, 2008).

There is also a protocol specifically designed for in-drain treatment technologies under the EPA's ETV program. Verification of In-Drain Treatment Technologies (2001) was developed under the Source Water Protection Pilot of the EPA and describes the detail criteria for the in-drain treatment technologies analysis procedure (In-Drain Treatment Technologies, 2001).

Besides those described by the WIDNR, special laboratory analysis procedures for TSS are available from the New Jersey Department of Environmental Protection, certifier for the NJCAT (NJCAT Laboratory Standard, 2009).

The following section discusses additional full-scale protocols.

2.4.1 *International BMP Database Protocol*

The International BMP Database was developed through support of the Water Environment Research Foundation (WERF), the American Society of Civil Engineers (ASCE)/Environmental and Water Resources Institute (EWRI), the American Public Works Association (APWA), the Federal Highway Administration (FHWA), and the U.S. Environmental Protection Agency (USEPA). The Database is intended to provide a consistent and valuable set of data on Best Management Practice (BMP) technologies and related performance (BMP, 2007). The BMP Database has almost the same criteria for sampling as the other protocols, except that the database includes a detailed procedure for the verification process specifically for structural and non-structural stormwater controls (including retention ponds, porous pavements, swales, grass filters, media filters, green roofs, etc.) (BMP, 2007). They require much more information describing the design of the stormwater control and the drainage area than most of the protocols. The following table is a brief comparison of the sampling requirements for the International BMP Database and the other major protocols (TAPE, TARP, and ETV). The listed water quality constituents desired for the International BMP Database is similar to the other major protocols.

Table 9. Comparison of BMP Database with Other Major Protocols

	BMP Database	Other Major Protocols
Minimum number of events	5	12-35
Minimum subsamples per event	5	5-10
Minimum storm depth (inch)	N.A.	0.1
Minimum time duration (hours)	6	6
Testing procedures	U.S. EPA method Standard Methods	U.S. EPA method Standard Methods ASTM method

2.4.2 *International Protocols*

There are only a few countries that have stormwater protocols for the evaluation of new technologies. European countries, including the United Kingdom, do not have specific stormwater regulations. The British Board of Agreement (BBA) does regulate construction products and materials, but they do not include any protocols for evaluating stormwater quality treatment technologies (BBA, 2010). UK regulations mainly focus on volume reduction rather than the quality of effluent water. Canada uses the U.S.EPA's ETV protocol for the verification of new stormwater technologies and also applies the laboratory procedures of the ASTM methods (ETV Canada, 2010). In Japan, eutrophication associated with stormwater nutrient discharges is a recognized wide-spread problem. However, there is no stormwater quality regulation yet developed. Japan has developed a flood control system and regulates the volume of runoff, however; there is no regulation for stormwater quality.

2.5 Statistical Analyses for Data Presentations

There are many different statistical methods used to present the results of the stormwater technology evaluations. Different methods used to present the test results may be used during the presentation of results of protocol tests, but care needs to be taken so consistent comparisons with objectives and between devices can be made. The following sections summarize some of the conflicts and technical difficulties associated with different data presentation methods that are commonly used to describe the effectiveness of stormwater control devices.

2.5.1 *Numbers of Storms to Monitor*

Throughout the country, there are seasonal differences in precipitation amounts, inter-event periods, and intensities. The number of influent/effluent sample pairs collected for an evaluation of a stormwater treatment device is critical. In many cases, too few sample pairs are collected, resulting in too few data for suitable statistical tests and low power. The larger the number of samples collected, the smaller the difference in influent and effluent concentrations that can be detected with appropriate confidence and power. Some of the protocols use the methods described by Burton and Pitt (2001) to determine the number of sample pairs needed for different data quality objectives.

Burton and Pitt (2001) summarize experimental design objectives and sampling need interactions. The following equation can be used to estimate the needed number of samples for a paired comparison:

$$n = 2 [(Z_{1-\alpha} + Z_{1-\beta})/(\mu_1 - \mu_2)]^2 \sigma^2$$

where α = false positive rate ($1-\alpha$ is the degree of confidence. A value of α of 0.05 is usually considered statistically significant, corresponding to a $1-\alpha$ degree of confidence of 0.95, or 95%)

β = false negative rate ($1-\beta$ is the power. If used, a value of β of 0.2 is common, but it is frequently ignored, corresponding to a β of 0.5.)

$Z_{1-\alpha}$ = Z score (associated with area under normal curve) corresponding to $1-\alpha$

$Z_{1-\beta}$ = Z score corresponding to $1-\beta$ value

μ_1 = mean of data set one

μ_2 = mean of data set two

σ = standard deviation (same for both data sets, same units as μ . Both data sets are also assumed to be normally distributed.)

This equation is only approximate, as it requires that the two data sets to be normally distributed and have the same standard deviations. Most stormwater parameters of interest are likely closer to being log-normally distributed. If the coefficient of variation (COV) values are low (less than about 0.4), then there is probably no real difference in the predicted sampling effort, but such low COV values are rare for stormwater. This method can be applied to log-transformed data for more accurate evaluations, but the confidence limits are uneven.

Figure 1 is a plot of this equation (normalized using COV and differences of sample means) showing the approximate number of sample pairs needed for an α of 0.05 (degree of confidence of 95%), and a β of 0.2 (power of 80%). As an example, twelve sample pairs will be sufficient to detect significant differences (with at least a 50% reduction in the influent concentration values), if the coefficients of variation are no more than about 0.5.

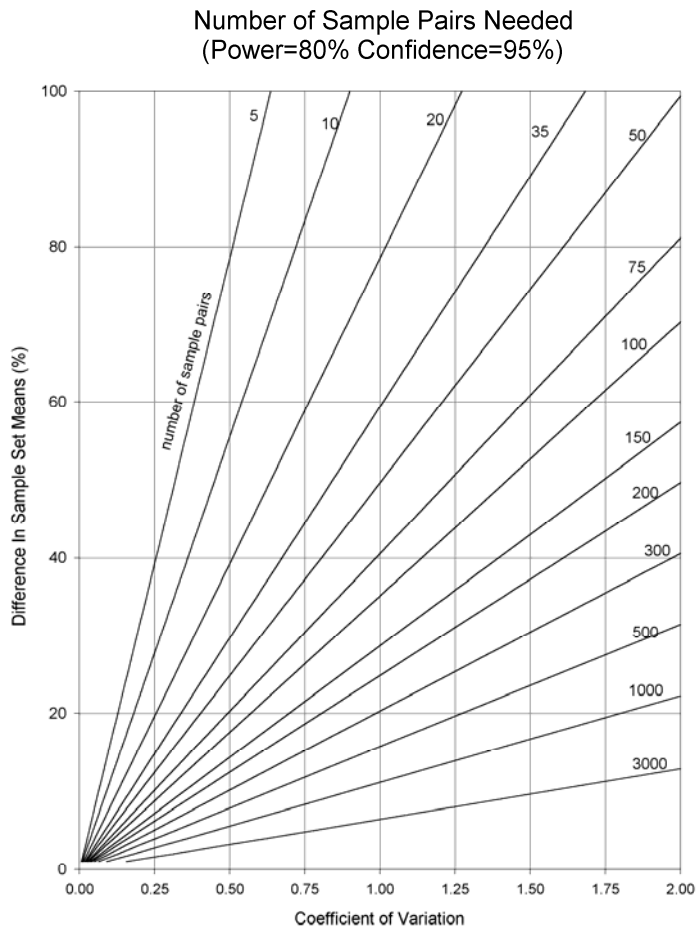

Figure 1. Sample Effort Needed for Paired Testing (Power of 80% and Confidence of 95%) (A. Burton & R. Pitt, 2001)

More detailed power tests can be used after the data have been collected to better determine the power of the statistical tests using the actual data distribution and a preset confidence value.

The major protocols previously described require paired sampling of 12 to 35 events. With typical stormwater COV values of about 1, this would require that the influent to be 1.6 to twice the effluent concentrations, in order to be statistically identified. However, as noted below,

treatment effectiveness is highly dependent on influent concentration, and concentrations can vary greatly from storm to storm. It is therefore important that the samples to be obtained covering a wide range of storm types and influent concentrations. Covering the complete range of stormwater conditions is difficult with few samples; larger numbers of samples that better represent the range of expected conditions allow a better understanding of how a stormwater treatment device operates under the anticipated wide range of local conditions.

2.5.2 *Short-Comings Associated with Pollutant Percent Removal Performance Requirements*

The description of performance of a treatment technology can be confusing because of the different objectives for the use of the data. TMDL (total maximum daily load) discharge goals set in NPDES discharge permits are usually established based on concentration conditions in receiving waters under critical flow conditions needed to achieve the recognized beneficial uses. These concentrations are multiplied by the critical flow rates and result in load (lb/day) goals. These loads are allocated to the various dischargers in a watershed or region. When compared to current discharges, discharge reductions, usually expressed in percentages, are calculated. Therefore, an agency may set a percentage reduction goal needed for stormwater in a watershed, even though the original criterion was based on receiving water concentrations. The same percentage reductions are also applied across a range of similar dischargers in an attempt to be equitable. Hence, the common use of a treatment goal of TSS for 80%.

However, the common 80% TSS removal criterion established by some protocols and state agencies can be misleading. Lenhart (2007) describes an example where the influent TSS concentrations are a very low 20 mg/L. In this case, an 80% reduction results in required effluent concentrations of 4 mg/L, which is lower than any normal stormwater treatment technology

could achieve consistently. For common treatment technologies, irreducible concentrations can be identified which is the lowest achievable effluent concentration (Schueler, 1996). Schueler shows that the irreducible concentrations of TSS in most stormwater treatment system effluents are commonly in the range of 20 to 40 mg/L (Schueler, 1996). Again in Lenhart's example, if the influent concentrations are already at 20 mg/L or below, clearly any additional TSS removal is very unlikely. If the influent concentrations of the monitored site are continuously low, the reported percentage removal rates will also be low. Lenhart suggests the use of the Performance Expectation Function (PEF) which is based on target effluent concentrations, percent removals, and load reductions. Lenhart's method results in a baseline concentration for the lower concentration influent events and a required percentage removal for the higher influent concentration events. However, this method requires significant amounts of data in order to establish the performance curve over the range of influent concentrations. The following figures illustrate Lenhart's example. Black dots indicate the observed data (Lenhart, 2007). Once the Performance Expectation Curve is established, it will be a good indicator to determine the target effluent quality from the influent concentration.

Performance Expectation Curve - Influent vs. Effluent

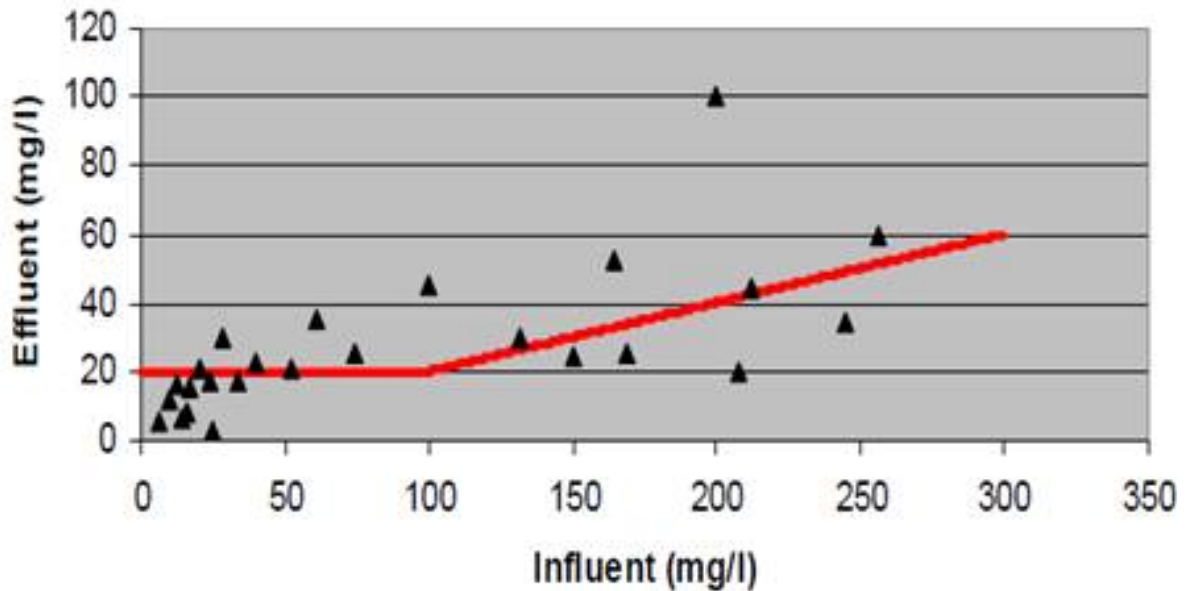

Figure 2. Lenhart's Performance Expectation Curve (Lenhart, 2007)

2.5.3 Percentage Reduction and Effluent Quality

The TAPE protocol specifies an 80% total suspended solids (TSS) removal criterion for the acceptance of a device (TAPE, 2002) for a set range of influent concentrations. TAPE considers this necessary to ensure that the technology being evaluated can achieve both the necessary effluent concentrations and the required percent removals. In the extreme case, if a nearby source of sediment results in extremely high influent TSS concentrations, the percentage removal rates are more likely to be very high, but the effluent quality may still be poor (high effluent TSS concentrations). Therefore, TAPE further specifies an 80% removal goal for TSS when the influent TSS concentrations range between 100 and 200 mg/L. For influent

concentrations greater than 200 mg/L, it is expected that the removal rate would be generally high and the application should just state a “higher treatment goal” will be the target. For influent concentrations less than 100 mg/L, the treatment technology should achieve an effluent goal of 20 mg/L TSS (TAPE, 2002).

2.5.4 *Percent Removal and Particle Size Distribution*

The usefulness of the 80% reduction goals can be improved if used with a better understanding of the particle size distributions (PSD) of the influent suspended solids. As an example, if all the influent particle sizes are extremely small, *e.g.*, less than 5 μm , it would be very difficult to achieve a high rate of TSS removal, even if the concentrations are very high, due to the inability of most stormwater control practices to remove these very small-sized particles. However, if a control device is located near a source area generally only having large particles (*e.g.*, >100 μm), the removal rates can be much greater for the same TSS influent concentrations.

Pitt et al. (2007) reports that about 90% of all stormwater particulates monitored at outfalls, by mass, are in the range of 1 to 100 μm , while about 10% of the particles can be larger than 400 μm . A useful protocol should, therefore, consider the particle size distribution (PSD) of the influent TSS particulates and set logical criteria. As an example, target effluent concentrations or percentage reduction goals may only be applied for particles larger than 5 μm (not 50 μm as sometimes applied). Some protocols using controlled laboratory tests specify influent particle distributions that need to be added to the influent water (typically a Sil-Co-Sil designation or formula, based on ground silica obtained from U.S. Silica Co.). It is difficult to specify a particle size range for influent TSS during full-scale tests under actual rain conditions. However, the data analyses need to include PSD tests and the statistical tests should include specific PSD analyses, as shown in later sections of this dissertation.

2.5.5 *Field Testing Challenges*

Full-scale field testing under actual rain conditions to evaluate the performance of stormwater technologies is difficult to control. Each site has different pollutant concentrations, different rainfall characteristics, and different site hydrologic conditions. Therefore, standard lab test protocols have been available for evaluating treatment technologies, either as an interim step to certification/verification or as a replacement to field testing. Controlled lab tests should be repeatable and comparable between devices, but they rarely, if ever, achieve conditions representing actual field conditions. Therefore, results obtained from the controlled lab tests, usually based on prototype devices; need to be adjusted to consider the increased variability that will be observed in the field.

Another potential problem arises from the use of automatic samplers. Clark et al. (2008) and Clark et al. (2009) investigated the performance of automatic samplers under different sampler conditions and concluded that the peristaltic pump driven samplers are not able to accurately sample particles larger than several hundred micrometers, especially when the elevation of the sampler above the water surface exceeds 2.5m. Therefore, complete mass balances must be conducted for the sampling period: all events in the sampling period need to be sampled, and at the end of the sampling period, the mass of pollutants collected in the device needs to be compared to the calculated removal based on measured removals from the automatic samplers. Automatic samplers also require a set period to collect samples, possibly not being able to keep up with rapidly changing flow conditions. This problem can be mostly overcome by obtaining a large number of subsamples during the flow-weighted sampling period.

Evaluating a treatment technology at different scales, in the laboratory and in the field, and at different steps in the development, is the most reasonable approach to developing an

effective stormwater control device and to understanding its performance. Preliminary lab tests result in valuable information needed for prototype development. Small-scale prototype field tests are scaled up lab tests and can be tested during both controlled and actual events, further improving the reliability of the evaluation. The final full-scale tests, again with controlled and actual events, are the most valuable and indicative of actual treatment conditions. However, as shown in this research, there was a need for testing (and protocols) for different test environments and conditions during device development and evaluations. The results from the research on the upflow filter were compared for the different test conditions and scales to demonstrate the advantages and limitations of each approach, especially when predicting the performance under full-scale real-world conditions.

2.5.6 *TSS Reduction Criterion and/or TP Removal Requirements*

Phosphorus is a common nutrient that is also described in some of the existing protocols. It is a nutrient that can cause significant water quality degradation when present in excess amounts. Human activities through agricultural practices, industrialization, and urbanization significantly contributed to the eutrophication of water bodies, which is an expanding global problem. States, including Maine, New York, Virginia, Wisconsin, and Minnesota, are aggressively addressing the removal of total phosphorus (TP) and specific regions in New York State are targeting 65% reductions for TP (MDM, 2010; MSM, 2007). TARP contains TP reduction goals of 50% when the influent TP concentration is in the range of 0.1 to 0.5 mg/L (enhanced treatment protocol). TAPE recommends the evaluation of TP in addition to the primary constituent of TSS as an enhanced evaluation of the stormwater technology (TAPE, 2002).

Successful stormwater control technologies result in the removal of a broad range of pollutants, including debris and floatable materials, over a wide range of flows. From a practical standpoint, limiting the evaluation of technology performance to only TSS and TP reduction may not be suitably comprehensive for all areas. Rather, it may be better to expand the evaluations to a broader range of likely contaminants. Some treatment technologies can be modified to target narrower ranges of contaminants, especially media filtration when sorption and ion exchange are the main treatment mechanisms and are relatively specific for the contaminants that can be controlled. However, very high levels of treatment can be accomplished for a wide range of contaminants, such as in the Multi-Chamber-Treatment-Train (MCTT) developed by Pitt, et al. (1999), but usually at a sacrifice in size (large) and treatment flow rate (relatively low per unit area).

2.6 Review of the Upflow Filtration Technology

The upflow filtration device being studied during this research can capture large amounts of sediment in the sump, reducing clogging problems. The device is installed in a chamber similar to a catch basin, and the main sedimentation and floatables capture occurs in this main compartment. Further treatment is provided as the stormwater passes through specifically-designed media prior to discharge. Because of the upflow filtration and associated partial bed expansion of the media, high treatment flow rates and decreased clogging occur simultaneously, which does not occur in downflow filters. The following section briefly reviews the components and their interactions within the device.

2.6.1 *Definition and Purpose of Catch Basin*

A catch basin is usually at the entrance to the storm drain system below an inlet grating. Catch basins, by definition, have a sediment sump intended to capture sediment and debris to keep these coarse materials from depositing in the stormwater drainage system and causing maintenance problems (Lager, Smith, & Tchobanoglous, 1977). A simple storm drain inlet, by definition, does not have a sediment sump, however; these terms are used interchangeably in practice. Stormwater usually enters the storm drain system through a grating along the curb. As noted, the main purpose of a catch basin is to trap coarse debris to prevent clogging of the drainage pipe and prevent odors from combined sewers by providing a water seal.

2.6.2 *Geometries of Catch Basins*

In the USA, there is no standard catch basin geometry (Lager et al., 1977), although they are relatively standardized in each city for periods of time. Currently, 4 ft diameter concrete catch basins are the most common for new construction. In Europe, catch basin sizes vary, but are standardized in different countries. They are usually termed gullypots instead of catch basins and are used as water seals in combined sewer systems. European catch basins are smaller in size, with smaller drainage areas, per inlet. Figures 3 and 4 show typical older catch basin styles used in the USA, Canada, and Europe.

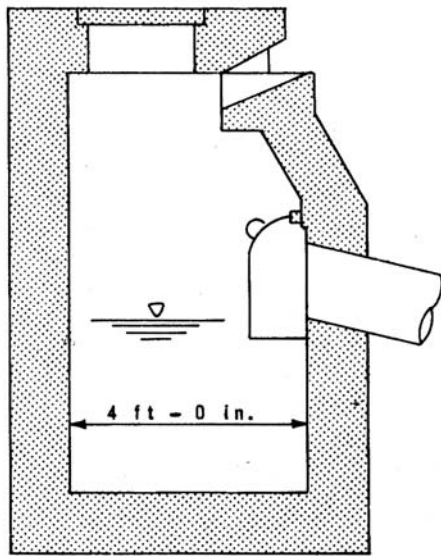

NEW YORK

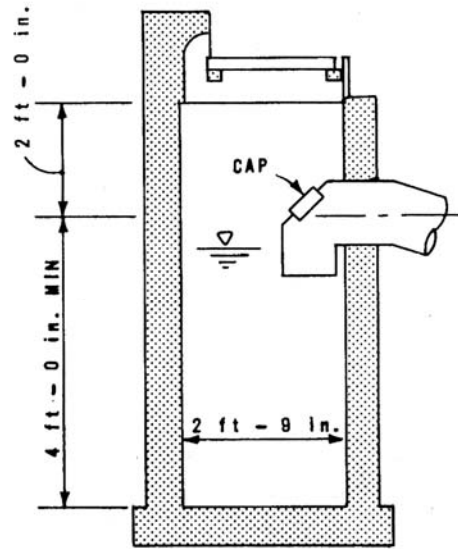

SAN FRANCISCO

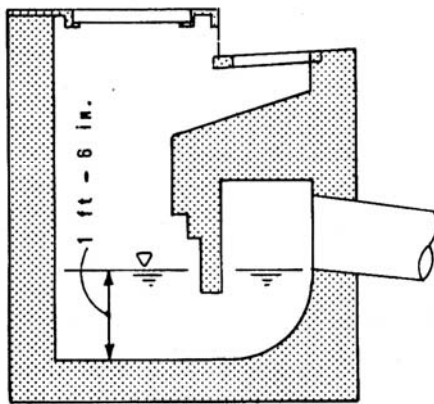

ATLANTA

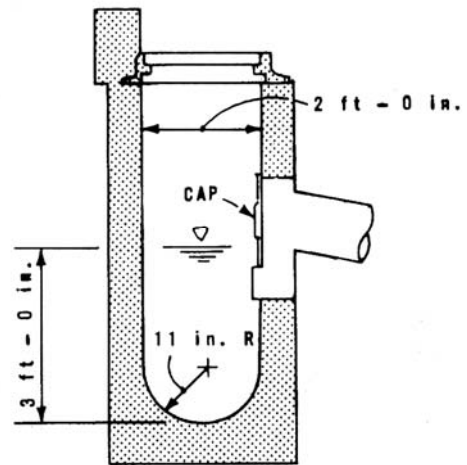

TORONTO

Figure 3. Typical Catch Basin Designs in United States and Canada (Lager et al., 1977)

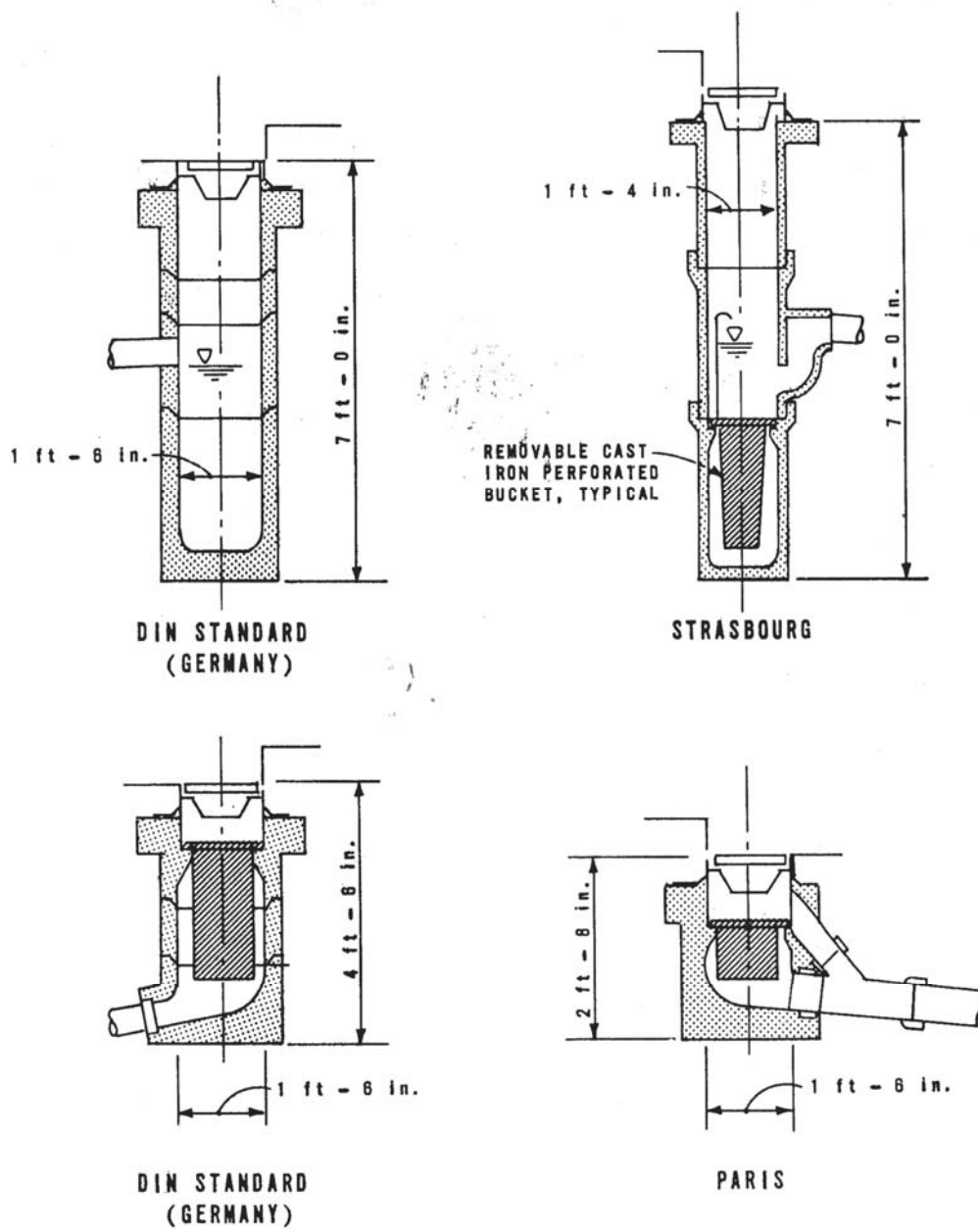

Figure 4. Typical Catch Basin Designs in Europe (Lager et al., 1977)

A recommended geometry for catch basins to enhance sediment capture was determined by hydraulic modeling analyses by Lager et al. (1977). Pitt (1979) and Avila (2008) verified the model under laboratory and field conditions. The recommended geometry of catch basin is shown in Figure 5. If the outlet diameter is D_2 , the total height of the device is $6.5D_2$, the diameter of the manhole is $4D_2$, and the bottom edge of the outlet pipe is located $4D_2$ above the device bottom and $1.5D_2$ below the top.

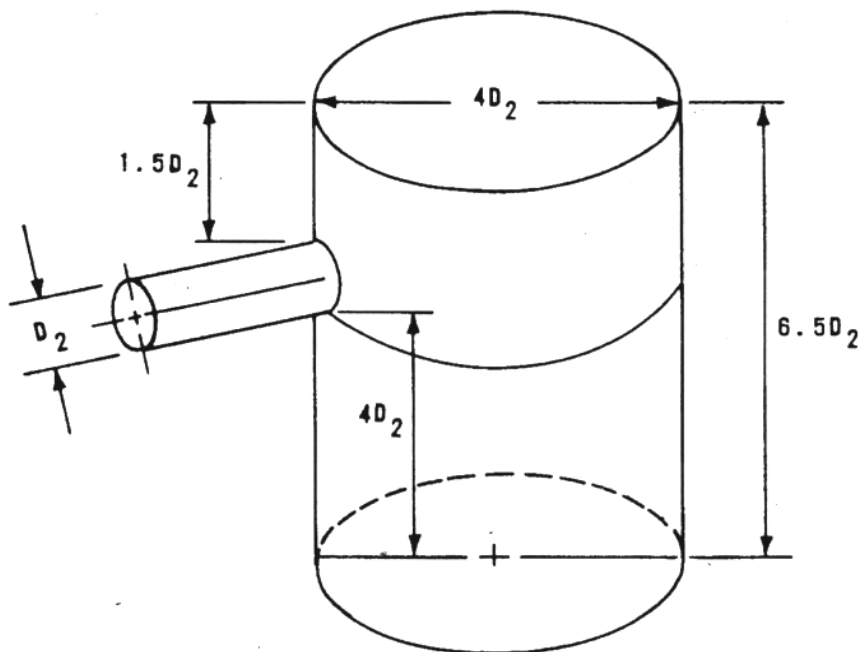

Figure 5. Recommended design (Lager et al., 1977)

2.7 Stormwater Pollutants

Stormwater pollutants can be categorized as floatable, suspended, and dissolved materials. Stormwater carries many types of pollutants including trash, sediment, nutrients, metals, and

bacteria. Many previous researches concluded that automobile activities contribute heavy metals to the street surface and runoff (Pitt, 1979; Shaheen, 1975). Pitt (1979) determined that tire wear is a major source of zinc, along with runoff from areas having galvanized metals. Other sources of pollutants can include atmospheric deposition, but Pitt, et al. (2004) concluded that only small portions of the atmospheric deposition material is expected to directly contribute to runoff for most situations. Pitt, et al. (2008) collected and evaluated stormwater data from NPDES (National Pollutant Discharge Elimination System) and MS4 (municipal separate storm sewer system) monitoring activities to describe the characteristics of stormwater quality nationwide for different conditions. Data has been collected over a ten year period and includes information from more than 8,500 events from about 100 municipalities throughout the country, representing several major land uses. Table 10 is a summary of these data.

Table 10. Summary of Selected Stormwater Quality Data included in NSQD, Version 3.0 (Pitt et al., 2008)

	TSS (mg/L)	COD (mg/L)	Fecal Colif. (mpn/100 mL)	Phosphorus, total (as P, mg/L)	Cu, total (µg/L)	Zn, total (µg/L)
All Areas Combined (8,139)						
Average	137.0	77.6	47665	0.4	30.1	181.1
Coef. of variation (COV)	2.2	1.1	5.0	2.8	2.1	3.3
Median	62.0	53.0	4300	0.2	15.0	90.0
Number of samples	6780	5070	2154	7425	5165	6184
% of samples above detection	99	99	91	97	88	98
All Residential Areas Combined (2,586)						
Average	122.7	68.8	55891	0.4	27.1	123.2
Coef. of variation (COV)	2.0	1.0	5.7	1.6	1.9	3.3
Median	59.0	50.0	4200	0.3	12.0	70.0
Number of samples	2167	1473	505	2286	1640	1912
% of samples above detection	99	99	89	98	88	97
All Commercial Areas Combined (916)						
Average	118.2	90.7	26065	0.3	31.4	197.5
Coef. of variation (COV)	1.7	1.0	3.0	1.2	1.4	1.4
Median	55.0	63.0	3000	0.2	17.9	110.0
Number of samples	843	640	270	920	753	839
% of samples above detection	97	98	89	95	85	99
All Industrial Areas Combined (719)						
Average	171.0	97.6	47329	0.4	40.6	243.9
Coef. of variation (COV)	1.7	1.3	6.1	1.4	2.1	1.7
Median	73.0	59.0	2850	0.2	19.0	156.2
Number of samples	594	474	317	605	536	596
% of samples above detection	98	98	94	95	86	99
All Freeway Areas Combined (680)						
Average	113.7	88.2	8553	0.7	33.7	162.4
Coef. of variation (COV)	2.6	1.0	2.7	5.2	2.2	1.4
Median	53.0	64.0	2000	0.3	17.8	100.0
Number of samples	360	439	67	585	340	587
% of samples above detection	100	100	100	99	99	99
All Institutional Areas Combined (24)						
Average	47.0	62.6	3100	0.2	24.7	308.7
Coef. of variation (COV)	1.1	1.0	0.4	0.9	0.6	0.9
Median	18.0	37.5	3400	0.2	21.5	198.0
Number of samples	23	22	3	23	21	22
% of samples above detection	96	91	100	96	57	100
All Open Space Areas Combined (79)						
Average	36.5	22.3	7323	0.1	9.2	59.1
Coef. of variation (COV)	1.8	0.6	1.2	1.5	0.4	0.8
Median	10.5	21.3	2300	0.0	9.0	57.0
Number of samples	72	12	7	77	15	16
% of samples above detection	97	83	100	97	47	50

2.8 Up-Flo[®] Filter Technology Background

2.8.1 *General Technology*

The Up-Flo[®] Filter was tested during this research. As noted, prior data were available from controlled laboratory experiments (Andoh, Pitt, Togawa, & Osei, 2009a, 2009b; Khambhammettu, 2006; Pitt & Khambhammettu, 2006; Pratap, 2004). The Up-Flo[®] Filter was commercialized by Hydro International as part of the EPA SBIR project that developed the concept. It is a high capacity subsurface filtration system that can be retrofitted into an existing storm drain manhole, or easily installed in new systems using conventional components. The system can contain from two to six filter modules, with each module having a treatment flow rate of about 20 to 30 gal/min/ft². It is designed with a treatment train concept that incorporates a catch basin having a settling chamber and a screen (sedimentation and screening), plus fine sediment filtration, ion exchange and sorption in the media, with unit processes similar to the MCTT (Pitt et al., 1999). A draindown system allows water levels in the chamber to stay below the filter media between events, which prevents the media from remaining saturated and becoming anaerobic. Flows larger than the treatment flow rate are bypassed through the bypass weir, which also has a floatable trap. Periodic inspection and maintenance is required to sustain the designed filtration rate, with cleanout usually conducted every year for most installations. The major components of a 6-module configuration in a 4-ft manhole are shown in Figure 6.

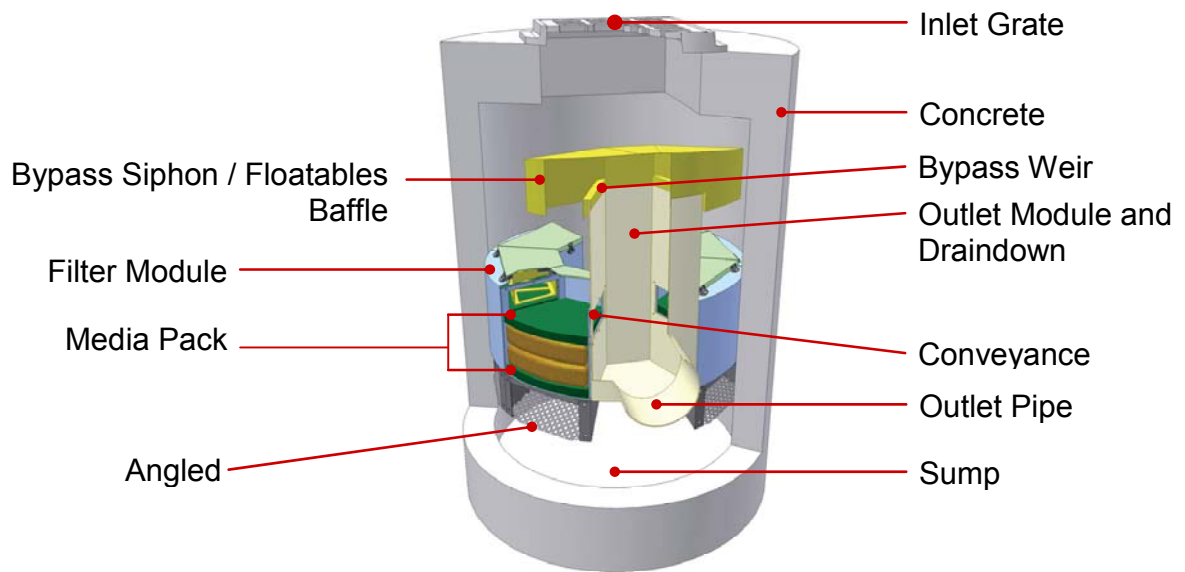

Figure 6. Up-Flo® Filter Component (Hydro International Drawing, 2010)

2.8.2 Operation

Up-Flo® Filter treatment is initiated during a storm event when stormwater is conveyed into the chamber from surface inlets or directly from the subsurface pipe network of the drainage system. Once flow enters the sump chamber, large debris and sediment settles in the sump and floating debris tends to rise up to the surface. The siphon serves as a floatables baffle to prevent the captured floatable trash from escaping the sump chamber. If the flow rate exceeds the treatment flow capacity, water is discharged through the Bypass Weir without filtration. In the pilot-scale experiment conducted by Pitt and Khambhammettu (2006), the maximum flow capacity was about 25 GPM per square foot of filter area.

2.8.3 Filtration Module

The flow enters the filtration module in an upward direction, passing through an angle screen and the media pack before entering the conveyance slot where the filtered flow is discharged into the outlet module. The filter module is shown in Figure 7 and consists of a bottom layer of flow distribution media, two filter bags with media, and a top layer of the flow distribution media. The flow distribution media is a polyethylene fiber web filtration media used to support the media bags and evenly disperse the flow across the entire surface of the media. The angled screens are designed to pre-screen larger debris, especially floatables, before the media filtration process and protect the filter module from clogging or other damage by the floatable materials. The angle is also designed to release any material that may have temporarily lodged on the screens during the upflow sequence, since the draindown sequence reverses the flow across the screen.

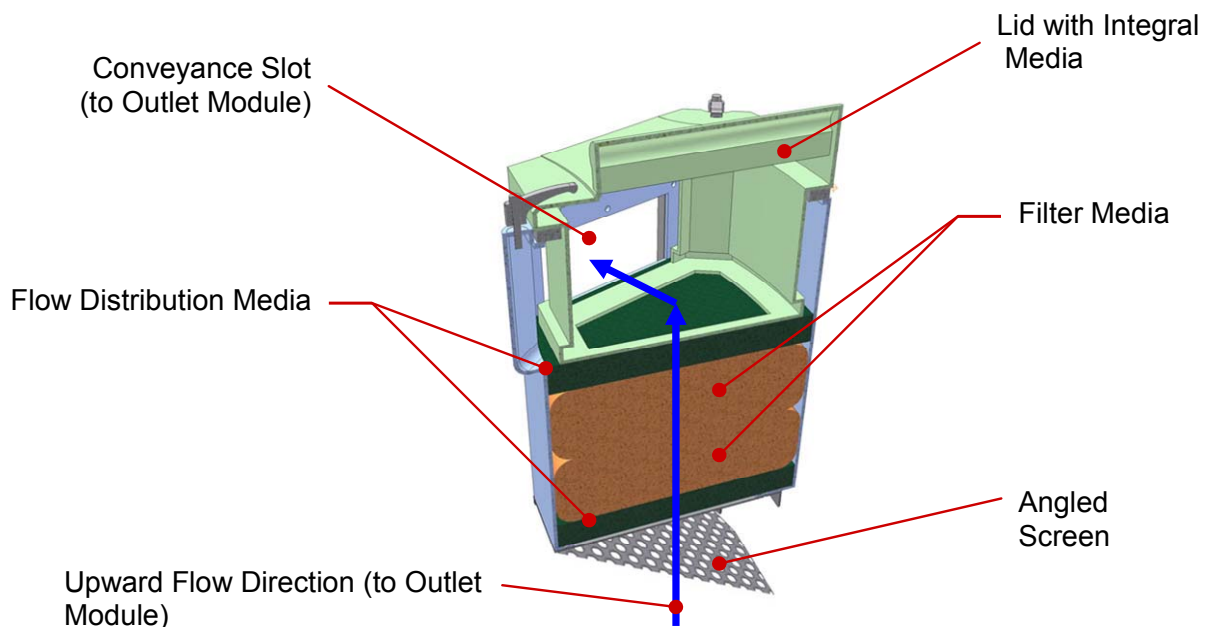

Figure 7. Filter Module Component (Hydro International Drawing, 2010)

2.8.4 *Filtration Process*

Before the water enters through the filter modules, larger particles settle into the sump, while smaller particles are kept suspended and drawn into the media. As the water flows upward through the media, the media becomes partially fluidized, allowing the particles to be trapped throughout the entire depth of the media bed, rather than just the first few inches. The sump and screen pre-treat the water by removing large particulates, and the upflow filtration process with the bed expansion greatly reduces the clogging potential in the filtration device, which increases the hydraulic loading rates (treatment flow water), as well increasing the filter life compared with traditional downflow filters. Treated flow exits the filter module and flows into the outlet module via a conveyance channel located above the media.

After a storm event, the remaining water in the unit below the conveyance slot is drained to a level below the media level in the filter module. The Up-Flo[®] Filter employs a siphon-activated draindown, shown in Figure 8, that prevents the media from remaining saturated and going anaerobic between events, which would contribute to media breakdown and release of contaminants (especially nutrients) from the media. The siphon drains the remaining water through the draindown which incorporates a screen prior to discharging into the outlet. During the operation of draindown, a backwashing effect allows captured pollutants near the bottom surface of the filter media and on the angled screen to be released to settle in the sump.

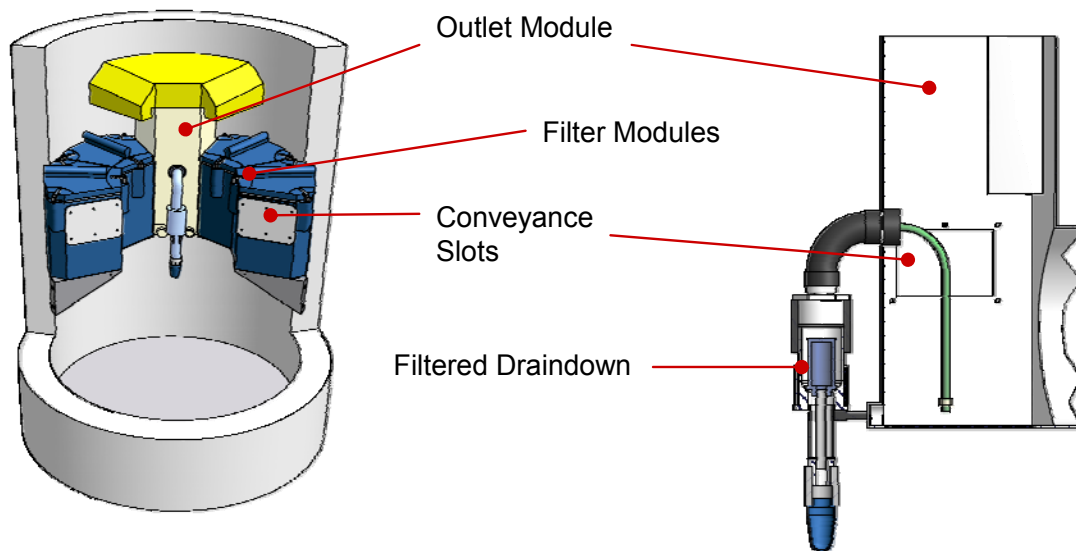

Figure 8. Outlet Module and Filtered Draindown (Hydro International Drawing, 2010)

CHAPTER 3

3: METHDOLOGY AND DESCRIPTION OF THE EXPERIMENTS

3.1 Introduction

Protocols have been developed to predict comparable performance of different stormwater control devices for real-world runoff conditions. The tests described in the existing protocols vary by scale and effort. A desirable protocol would be one that could be conducted quickly and inexpensively to measure performance in a laboratory-scale test and be able to accurately predict long-term performance under actual full-scale conditions for a broad range of actual storm conditions. The protocol framework development in this research aims to provide an infrastructure for the rapid evaluation of in-drain stormwater treatment technologies and an easy-to-use testing tool for existing and proposed protocols. Testing under a range of scales and conditions was needed in order to compare the existing protocols and to recommend improvements. This research used the upflow filtration device, because of its past history of testing at different scales, as the foundation for the comparison of existing protocols. Much of this comparison was based on previously published research on the upflow device (Andoh et al., 2009a, 2009b; Khambhammettu, 2006; Penn State Harrisburg, 2007; Pitt & Khambhammettu, 2006; US Infrastructure, 2003). However, additional field research was required to supplement the existing data and allow for the comparison of the field-testing protocols. The following section describes the field monitoring of the full-scale upflow filtration device (the Up-Flo[®]

Filter) that were conducted as part of this research from a full-scale data installation to compare with previously collected controlled and smaller-scale tests of the device and prototypes.

3.1.1 *Project Goals*

The overall goal of this project task was to collect field data of the upflow filtration device following as many of the elements of the four main testing protocols as possible including: TAPE, TARP, NJCAT, and ETV. NJCAT is mostly based on the TARP protocol. These data were compared to the performance data previously obtained during laboratory and field-scale tests of the unit processes and prototypes of this same device. Scaling effects were identified to indicate how well these preliminary and controlled tests were able to predict the performance under actual, full-scale conditions with the commercially available unit.

3.1.2 *Project Objectives*

The objectives of this research were to characterize, with a reasonable level of statistical confidence, the effectiveness of the Up-Flo[®] Filter for removal of total suspended solids (TSS) and other constituents from stormwater runoff for comparison with prior data collected under different conditions (lab and pilot-scale installations). The data was collected following as many elements of the four major protocols as possible, plus additional efforts that go beyond the minimum to enhance the comparisons. The Up-Flo[®] Filter were also assessed with respect to other factors such as maintenance, reliability, and longevity. The methodologies of the data collection and sample analysis activities consist of the following major components.

3.2 Available Data for the Analysis

The effectiveness of upflow filtration technology had been examined previously through the use of pilot-scale tests, laboratory tests, and field performance tests conducted under controlled and actual storm conditions (Andoh et al., 2009a, 2009b; Khambhammettu, 2006; Penn State Harrisburg, 2007; Pitt & Khambhammettu, 2006; Pratap, 2004). This research supplements the existing dataset through field testing of the commercially-available device under actual storm conditions. The EPA-funded Small Business Innovative Research (SBIR) project that developed the upflow filter was a two-phase program including bench-scale testing, pilot-scale testing, and field verification testing using a prototype. Different types of data were collected during the SBIR projects as well as during the current full-scale field test. The following paragraphs briefly describe the bench-scale data obtained during the SBIR I project, pilot-scale data obtained during the SBIR II project, and the current research which was used for the development and verification of the protocol framework.

Bench-scale Data. SBIR 1 (Bench-scale) project was designed to develop and demonstrate the effectiveness of upflow filtration for the treatment of stormwater runoff (US Infrastructure, 2003). This research was conducted in two phases: 1) bench-scale tests to evaluate potential pollutant removal capability of upflow filtration for solids and dissolved pollutants, 2) pilot-scale tests to evaluate pollutant removal using actual stormwater. The first phase was conducted using upflow filter columns; the flow was passed through the filter from the bottom, introducing the upflow filtration concept for stormwater treatment. Filter columns containing various media were constructed in glass graduated burettes (inner diameter of 50.8 mm), giving a cross-sectional area for filtration of 20 cm² (0.022 ft²). Four different filtration media were tested including fine grade sand, compost-sand mixed media, peat moss-sand mixed media, and coarser

sand alone. Test water was made mixing a tap water with clay having an approximate 0.5 g/L concentration. Both the influent and the effluent samples were collected and analyzed for turbidity and total suspended solids.

Phase 2 of the SBIR I analyses was conducted using actual stormwater runoff from a stormwater detention pond (Star Lake in Hoover, Alabama). This pond was fed by stormwater runoff primarily from a medium-density residential area. The filtration columns were constructed in large (55 gallon) polyethylene tanks using the same guidelines as was used in the phase 1 tests. The test was conducted for approximately 6 weeks, from June, 2003 to July, 2003. The same type of four different media were used and samples were analyzed for pH, conductivity, color, nutrients, heavy metals, COD, and bacteria, in addition to the turbidity and total suspended solids.

Pilot-scale Data. Pilot-scale field tests of the upflow filter were conducted by Khambhammettu (2006) as part of the Phase II project of the US EPA's Small Business Innovative Research (SBIR) program. Testing was conducted during both controlled flow tests and during actual rain events over a 10-month period using a prototype upflow filter. The test site was a retrofitted catch basin located in the parking lot of the Tuscaloosa City Hall, Alabama. The catch basin received runoff from a 0.9-acre drainage area consisting of parking, roofs, and adjacent storage areas. The prototype device was sized at approximately $\frac{1}{4}$ of the optimal size for the area, with a nominal 25 gpm peak treatment flow rate (excess flow would bypass the unit). The filtration rate required for treating 90% of the annual flows at the test site was estimated to be about 100 gpm, while the average runoff flow rate treated for the observed rain events during these tests was 44 gpm.

Controlled tests were first conducted using equal weight fractions of Sil-Co-Sil 250, Sil-Co-Sil 106, coarse sand, and fine sand, as test sediment. The test sediment particle sizes ranged

from 0.45 to 2,000 μm representing a wide range of particle sizes that may exist in stormwater. The particle size distribution was broader than expected in typical stormwater, as the concentrations of the larger particles were relatively large, ensuring that sufficient amounts of this material would exist in the influent samples to allow measureable removal rates of these large particles (the performance analyses were conducted on many separate particle size ranges). Twelve separate tests were conducted at high, medium, and low flow rates with four different influent concentrations during each flow period (approximately 500 mg/L, 250 mg/L, 100 mg/L, and 50 mg/L). The high flow rate was approximately 27 gpm (the highest flow obtainable from the adjacent fire hydrant), the medium flow rate was approximately 15 gpm, and the low flow rate was approximately 5 gpm. Test sediments were manually fed into the influent water over the complete period of each experiment. Effluent samples were collected using a dipper grab sampler every 1 minute and composited in a churn sample splitter during the 30-minute test period. Using the churn splitter, three samples of 1,000 mL each were collected for laboratory particle size and sediment analyses.

Automatic programmable samplers (ISCO 6712) were used to simultaneously collect subsamples of influent and effluent from the prototype upflow filter site during actual rain events. Thirty-one separate rain event periods were monitored during the 10-month period from February to November, 2005, and twenty-four sample sets were analyzed (Khambhammettu, 2006). After the field rain tests, the sump was drained and the captured material was removed and analyzed to confirm the sample-based performance observations by mass balance for the whole sampling period.

Full-Scale One-module Filter Data. Controlled laboratory testing of a single module full-size unit was conducted by the Penn State Harrisburg (PSH) Environmental Engineering (2007)

as part of the EPA's ETV program. The PSH Environmental Engineering Laboratory is a physical testing laboratory with space, tanks, piping, and utilities capable of performing medium scale (10-50 gpm) hydraulic testing. City water was used for the influent water source. A synthesized wastewater mixture containing petroleum hydrocarbons (gasoline, diesel fuel, motor oil, and brake fluid), automotive fluids (antifreeze and windshield washer solvent), surfactants, and sediments (sand, topsoil and clay), was used to simulate constituents found in typical stormwater runoff, as listed by the ISF In-Drain Testing Protocol. Influent and effluent samples were collected manually and analyzed for several parameters including: TSS, SSC, total phosphorus (TP), and chemical oxygen demand (COD). Flow rates and concentration of pollutants were controlled manually by the PSH personnel with flow rate ranging from 11 gpm to 50 gpm (greater than the design flow of 20 gpm). The pollutants concentrations of TSS, SSC, TP, COD ranged from approximately 50 mg/L to 600 mg/L, approximately 50 mg/L to 700 mg/L, 10 mg/L to 200 mg/L, and 30 mg/L to 500 mg/L, respectively. Four different phases of the tests were conducted with different conditions including 1) performance under intermittent flow conditions, 2) determination of capacity of the unit, 3) performance under varied hydraulic and concentration conditions, and 4) high hydraulic conditions. The Phase 1 intermittent flow tests were run for a 40 hour period. During the test, flow was continuously started or stopped for 15 minutes. During Phase 2 of the test, the unit was operated under continuous approximately 16 gpm conditions for 12 hr/day until the unit plugged with solids or the absorption capacity was exceeded. Phase 3 test was conducted under varied hydraulic and pollutant concentrations. The treatment flow rate was increased by 5 gpm in 15 min increments from the initial flow rate of approximately 10 gpm until flow began to bypass. The pollutant feeder hopper speed was also increased providing different concentrations of pollutants to the influent water. Phase 4 of the

test was conducted under high flow, at approximately 32 gpm (greater than the design flow of 20 gpm) in order to determine the performance of the unit under high hydraulic conditions. A total of 215 pairs of samples were analyzed under four different conditions (Penn State Harrisburg, 2007).

Initial Field Analyses. As part of the full-scale field tests, a detailed site survey and preliminary monitoring was conducted in order to understand the current stormwater characteristics present at the Bama Belle site. A total of 7 storms were monitored using grab sampling methods at the influent and effluent locations during the period of October, 2007 to April, 2008. Constituents analyzed were included sediments, particle sizes, metals, nutrients, and bacteria, along with the hydraulic characteristics of storm events as shown in Section 3.9.6 and Appendix A.

Installation of Full-Scale Filter. After the initial field analyses were conducted, the location for the installation of device was confirmed. A 7-foot tall, 4-foot diameter standard catch basin inlet containing a six module Up-Flo[®] Filter was installed at the Riverwalk parking lot near the Bama Belle excursion boat dock on the Black Warrior River in Tuscaloosa, Alabama. Test location detail are described in Section 3.9.1. A site survey further detailed the drainage area using; 1) two-foot contour map (Auto-CAD data obtained from Tuscaloosa Department of Transportation), 2) site survey during the storm with a verification of flow pass, 3) aerial photographs. An additional ten storms were monitored to characterize the hydraulic conditions during different rain events from January to June, 2010, in order to prepare and verify the sample programming of the automatic samplers.

Controlled Flow and Particle Capture Test. Controlled flow tests were then conducted to determine the treatment flow rate capacity and the sediment removal capabilities in a full-scale

field installation under controlled conditions. Twelve tests were conducted using four different concentrations of particulates (50 mg/L, 100 mg/L, 250 mg/L, and 500 mg/L) at each of three influent flow rates (approximately 25 gpm, 75 gpm, and 150 gpm). Controlled testing was conducted using specific combination of Sil-Co-Sil 250, Sil-Co-Sil 106, coarse sand, and fine sand as test sediment to represent a wide range of particle sizes in the test mixture. The test sediments were continuously poured into the influent water over the 30 minutes of each experiment. Effluent samples were collected using a dipper grab sampler every 1 minute and composited in a churn sample splitter, and two duplicate 1 L samples were then analyzed in the laboratory for each test.

Actual Field Monitoring. After the completion of the controlled flow tests, pollutant removal and flow monitoring during actual rain events were conducted, focusing on sediment, particle sizes, metals, nutrients, and bacteria. ISCO 6712 automatic samplers were used to simultaneously collect single composite influent and effluent samples during each rain event.

3.3 Design of Experiment

Analytical results from different scales, controlled flows and concentrations vs. actual rains, and test protocols for the upflow filtration device were available. The design of the experiments was developed to establish a protocol framework for evaluating critical source treatment devices. The framework was posted a series of questions that different experiments could address. These questions were included:

- How well does the technology perform under a wide range of flow and sediment characteristics?
- How do highly variable flows and sediment characteristics affect performance?

- How does the treatment flow rate change with operation of the technology?
- How long can the device operate before maintenance is needed?

3.4 Applicable State Criteria

Currently, the protocols are based on state political jurisdictions, with little regard to differences in stormwater characteristics or receiving water problems. Obviously, regional differences in characteristics and problems should be a consideration in the protocols. Pitt, et al. (2008) collected stormwater quality data from more than 8,500 events from about 100 municipalities throughout the country as part of the National Stormwater Quality Database (NSQD). This data was evaluated relating the observed concentrations to various factors including land use, geographical region, and season. Geographical factors were found to significantly affect stormwater concentrations for many of the constituents (land use factors were the most important. however).

During this research, the monitoring data (influent TSS concentrations) as well as the rain characteristics were statistically compared to the NSQD data to determine if the Bama Belle site is similar to the regional data, as shown in Chapter 4.6. Pilot-scale analysis data collected by Khambhammettu (2006) included about a month of initial field sampling and 10 months (from February to November, 2005) of performance monitoring. This older data collection site from the parking area was adjacent to the new City Hall, Tuscaloosa Alabama and the newer Bama Belle location had similar areas (0.9 ac) with slightly different land uses (the City Hall site included a large roof area and concrete deck and asphalt parking areas, while the Bama Belle site was mostly asphalt parking, with a small landscaped area around the perimeter). Again the differences in the TSS concentrations and rain characteristics were examined using the Kruskal-

Wallis Statistics to see if the pilot-scale data also represents the general trend of the regional data, as shown in Chapter 4.6. During analyses of the NSQD data, Maestre and Pitt (2006) found that land use was the most important factor affecting stormwater quality, with regional differences sometimes important. Seasonal factors were only important for bacteria, where observed concentrations were lower during the winter colder months.

3.5 Minimum Storm Event Criteria

One of the main questions in field monitoring to determine performance of a treatment device was: how many samples are required to infer acceptable performance? An inadequate sample size diminishes the utility of the results, specifically by losing power and the ability to measure lower levels of performance. If only large removals are expected, then fewer samples are needed. Sample size therefore influences the quality and accuracy of the analyses. The specification of precision (repeatability) is related to the tolerable amount of error in the sample estimate (Cochran, 1977). The alpha level, Type I error (a null hypothesis is incorrectly rejected when it is true) and the beta level, Type II error (a null hypothesis is not rejected despite being false) are the most commonly used measures in sample size selection. As noted above, the larger the number of samples collected, the smaller the difference in influent and effluent concentrations can be detected with appropriate confidence and power. Some of the protocols use the methods described by Burton and Pitt (2001) to determine the number of sample pairs needed for different data quality objectives.

The confidence level (alpha) and power level (beta) are highly influenced by the variance of the sample. As the variances increase, a larger number of samples are needed to satisfy the specified confidence and power levels. Field and controlled monitoring data were available from

pilot-scale and full-scale tests for pairs of influent and effluent pollutant concentrations. These data were used to determine the appropriate number of samples for the upflow filter field tests based on the expected removal rates. The actual rain event monitoring data was expected to show larger variations in influent concentrations compared to the effluent samples, as expected for highly effective stormwater controls. In contrast, during controlled experimental condition, variations in influent concentrations could be smaller than the effluent concentrations. Therefore, analysis of variation in influent and effluent concentration for the different conditions also verified the reliability of the upflow filter under changing conditions.

Cochran (1977) indicated four ways of estimating population variances for determining the sample size: (1) take the sample in two steps; a partial random sample variance is used to determine the population variance and also the sample size; (2) use pilot survey results, (3) use previous sampling of the same or similar population, (4) guess by the logical mathematical results. Tests were conducted using the different statistical formulas in paired analysis, equal variances, and unequal variances to see how the variances of the pollutants concentrations affected the determination of the minimum number of samples to detect the difference between influent and effluent, as shown in Chapter 4.7.

3.6 Minimum Rain Depth and Storm Duration Criteria

Another common component of the protocols is the specification of the minimum rain depth to be sampled and the rain durations. The minimum rain depth and rain duration are usually related each other, as small rains usually have short rain durations and longer rains usually have larger rain amounts. This criterion is based on how much depth and how long a storm is required to produce a significant amount of runoff in the particular drainage area. It may

depend on the land use, percentage of imperviousness, soil type, antecedent soil moisture, slope, and rain intensity.

Pitt and Voorhees (2002) developed the Source Loading and Management Model (WinSLAMM) which can be used to calculate runoff conditions for an area. These modeled values were compared with the actual rain data to see if the model could represent the actual storm conditions, as shown in Chapter 4.8. Complete hydrological information, including rain depth, rain intensity, runoff volume, runoff velocity, and water level, were available for each storm event. The data were used to identify the statistical relations for runoff volume, precipitation, and storm duration in Chapter 4.8. These data also related to the number of minimum subsamples to be collected during an event (the topic of the next subsection). As an example, small storms may not produce enough runoff volume for large numbers of subsamples.

3.7 Minimum Number of Subsamples per Event Criterion

The minimum number of subsamples to be collected during each event is another common component of the protocols. The desire is to ensure that sufficient subsamples are obtained to adequately represent the complete event. Most protocols also specify that the subsamples are to be collected during most of the event, with sometimes a specified number on the rising limbs of the hydrographs, near the peak flows, and other specifics. The number of subsamples that can be collected during an event is also related to the minimum rain depth and storm duration, as each subsample requires a specific amount of time for the automatic sampler to collect each subsample. The subsample frequency is usually programmed as a function of the amount of flow that has passed, and conflicts arise to ensure sufficient sample volume is

obtained for the required analyses during small rains and to ensure that the sample container is large enough to contain all of the subsamples during a large event.

A single composite sample was analyzed per event for both influent and effluent sampling locations, thus the subsamples needed to represent the characteristic of the entire storm. High resolution turbidity data obtained from the sonde were compared to the single composite sample data in order to determine if the single composite sample can represent the characteristics of the entire storm, as shown in Chapter 4.9 and Appendix F. The sonde data can be used to indicate likely variability of the concentrations during the event, and to indicate when large changes occur.

Some of the initial grab samples were collected during the first 30 minutes of the event to evaluate the “first flush” effect (high concentration of pollutant at the beginning of an event) in addition to the complete event flow-weighted composite sample. Maestre et al. (2004) used nonparametric statistical tests to comparing similar first flush and composite samples from the NSQD database. They concluded that generally, the first flush effect was larger for the smaller drainage areas that were mostly paved, compared to larger and more complex drainage areas. The BamaBelle site was small and heavily paved and, therefore, was expected to exhibit significant first flush effects as shown in Section 4.9 and Appendix F.

3.8 Minimum Time Between Event Criterion

Minimum antecedent time between monitored events is also a common criterion in the protocols. All of the major protocols require a minimum of six hours between qualified sampling events. This time has historically been used in urban stormwater research as it usually allows clean separations between event hydrographs and many of the impervious surfaces can dry

during that period. These specific characteristics obviously depend on the site conditions. There were no samples collected having antecedent times less than six hours during the monitoring period. The shortest antecedent dry periods were 24 hours. These data were used to examine effects of antecedent dry period on runoff characteristics in Chapter 4.10.

3.9 Initial Field Sampling

Initial field analyses were conducted at the beginning of the project in order to determine the best location for the installation of the treatment device and to characterize the stormwater characteristics for the different areas. Several prospective locations and inlets were examined in the Tuscaloosa, AL area, with the following site objectives:

- Having a single inlet and a single outlet where the unit could be installed to enable complete monitoring of flows.
- No other stormwater controls existing at the site
- Having a relatively simple drainage area, with a size of approximately 1 acre.
- At least moderate stormwater contamination at the test site is desired, or at least having a broad range of likely characteristics that will meet the needs of the different protocols.

3.9.1 *Test Location and Land Use*

The Up-Flo[®] Filter was installed at the Riverwalk parking area, a city-owned facility located near the Bama Belle excursion boat dock on the Black Warrior River in Tuscaloosa, Alabama, in early 2009. The latitude and longitude coordinates of the site were 33° 12' 50" N and 87° 34' 17" W. The device received surface runoff from the parking lot, driveways, sidewalks, and small landscaped areas, as described below. The Up-Flo[®] Filter was located

approximately 30 feet from the Black Warrior River, and treated effluent from the filter discharges directly into the river. Figure 9 shows the test site and Figure 10 indicates the location of the filter. The drainage area tributary to the device was approximately 0.9 acres. Table 11 shows the land covers within the drainage area.



Most runoff is coming from the parking lot



Sidewalks and roadway to the parking lot



Grass swale and turf area



Parking lot and landscaped area



Effluent pipe (before filter installation)



Turf area on the side of the road

Figure 9. Test Site at the Bama Belle Parking Lot



Figure 10. Aerial Map by Microsoft Corporation Bird's Eye (2010)

Table 11. Drainage Area and Land Use

Land Use	Area (ft ²)	Area (acre)	% of Land Use
Paved Parking	11,800	0.27	30.5
Other Paved Areas	1,300	0.03	3.4
Paved sidewalks	2,100	0.05	5.4
Paved driveways	10,990	0.25	28.5
Green Space	12,400	0.29	32.2
Total	38,610	0.89	100.0

3.9.2 Pollutant Sources and Site Maintenance

The main pollutant sources within the drainage area were associated with vehicular activity (sediments, heavy metals, and organic toxicants), erosion from the landscaped areas

(sediments, nutrients, other landscaping chemicals, and plant debris), and park activities (bacteria from pets and urban wildlife and landscaping maintenance). The City of Tuscaloosa infrequently cleaned the site road and parking lot areas. There were no other stormwater control practices within the small drainage area.

3.9.3 *Water Quality and Water Resources*

The receiving water for the runoff from the site was the Black Warrior River, which is a tributary of the Tombigbee River. The Black Warrior River is approximately 178 miles long and is located in west central Alabama. The river drains an area of 6,275 square miles. There are several dams and locks on the river. Barge traffic along the river is usually carrying coal from mines to power plants.

3.9.4 *Local Meteorological Conditions*

The Tuscaloosa area climate, according to the University of Alabama meteorology group in the Department of Mathematics, has a typical Southern subtropical climate. The Gulf of Mexico heavily influences the climate by supplying the region with warm and moist air. In the fall, winter, and spring seasons, this warm and moist air interacts with cooler and drier air from the north and produces precipitation. There is a different climate occurring during the hurricane season, usually starting around June and ending in November. Storms may move from south to north or even from east to west after hurricanes make landfall.

The winter season lasts from mid-December to late-February, with temperatures typically ranging from about 20° F to 50° F. The average monthly rainfall depths are about 5.1 inches during the winter season. Tuscaloosa usually has a mild winter, with average annual snowfalls of 0.6 inches, which occur very infrequently. The spring season is between late-February to mid-

May with temperatures typically ranging from about 50° F to 80° F. Average monthly rainfall depths are also 5.1 inches during the spring season. Summer lasts from mid-May to mid-September and temperatures typically range from about 60° F to 90° F. During the summer season, the temperatures in Tuscaloosa often peak above 100° F and average rainfall is 4.0 inches per month. The fall season is between mid-September and early-December, having similar temperatures and lower precipitation than the spring season, with the lowest annual rains in October. Table 12 shows the average high and low temperatures and the average rainfall for Tuscaloosa by month. Federal agencies have collected weather data in the Tuscaloosa area for many years, including the Corps of Engineers efforts since at least 1958 at the Oliver Dam.

Table 12. Temperature and Precipitation Summary for Tuscaloosa (National Climatic Data Center, 1994-2010)

Month	Jan	Feb	Mar	Apr	May	Jun	Jul	Aug	Sep	Oct	Nov	Dec	Year
Average High (°F)	58	61	67	77	84	91	93	93	87	78	66	58	76
Average Low (°F)	35	38	43	51	59	67	70	69	63	51	39	35	52
Average Rainfall (in)	5.0	5.5	6.1	4.3	4.4	3.4	4.0	3.0	3.3	2.7	3.9	4.7	50.3

Figure 11 shows a Tuscaloosa IDF (intensity-duration-frequency) curve prepared using the Alabama Rainfall Atlas software program developed by Dr. S. Rocky Durrans of the University of Alabama. Tuscaloosa has relatively high rainfall intensities for short 5-minute durations, ranging from approximately 7 in/hr for rains having a 50% chance of occurrence in any one year (2-yr frequency storm), to about 11 in/hr for rains that may occur once in a 100 years (100-yr frequency storm).

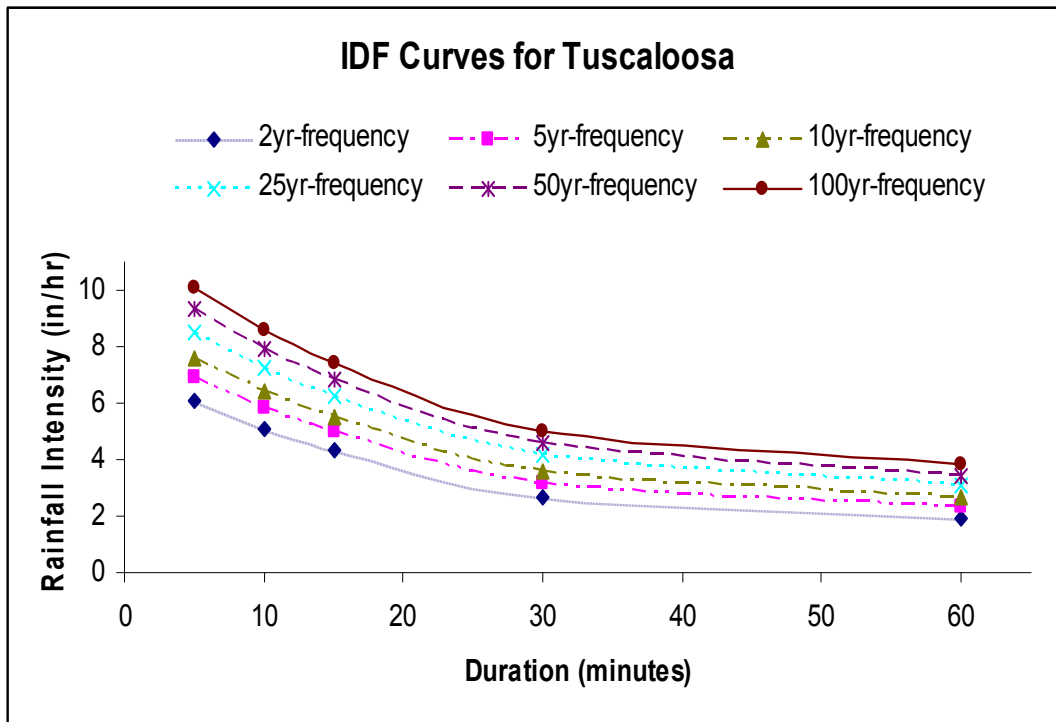

Figure 11. IDF Curves for Tuscaloosa (Alabama Rainfall Atlas, S. Rocky Durrans)

3.9.5 Stormwater Treatment Flow Rates

The best stormwater treatment flow rates for an area maximize the fraction of the total annual flows that are treated at a high level during a typical rain year, while minimizing the bypass quantities that are partially treated. The annual series of continuous flows from all of the rain events can be calculated to help determine the suitable treatment flow rate.

Figure 12 is a plot showing the percentages of the total annual stormwater discharges associated with different flow rates (in gallons per minute) for the Tuscaloosa, AL, test site evaluated during prior pilot-scale evaluations of the Up-Flo filter. These flows were calculated using a calibrated version of WinSLAMM for a 0.9 acre test site (0.4 acre roof and 0.5 acre paved parking), and for the first nine months of the 1999 rain year (determined to be

representative of a typical rain year). A typical annual rain series should not include any unusual events that would be represented by relatively rare drainage design storms. Therefore, the highest runoff rates calculated from these analyses are therefore less than what would be expected when using the IDF curves shown in Figure 11.

The continuous simulation calculated the flows for every 6 minute increment during this period. As an example, with a treatment flow rate of 44 gpm (the average value for the observed events of the small pilot-scale filter), the total event would be treated if the peak flows were less than this value. During periods of peak flows greater than this value, the base 44 gpm would be treated by the Up-Flo[®] Filter, while higher flows would bypass the filter unit. About 25 to 30% of the annual flows are expected to be less than or equal to a 44 gpm treatment flow rate for this 0.9 acre site, as shown on Figure 12. However, a larger fraction of the annual flows were actually treated. Figure 13 is a plot of the expected fraction of the annual flows that would be treated by the Up-Flo[®] Filter for different treatment flow rates, considering complete treatment for events having smaller flows and partial treatment for larger events. For a 44 gpm treatment flow rate, about 60% of the annual flows would be treated, and about 40% of the runoff volume would bypass treatment. As another example, in order to treat about 90% of the annual flows at this 0.9 acre impervious site, the treatment flow rate should be about 100 gpm.

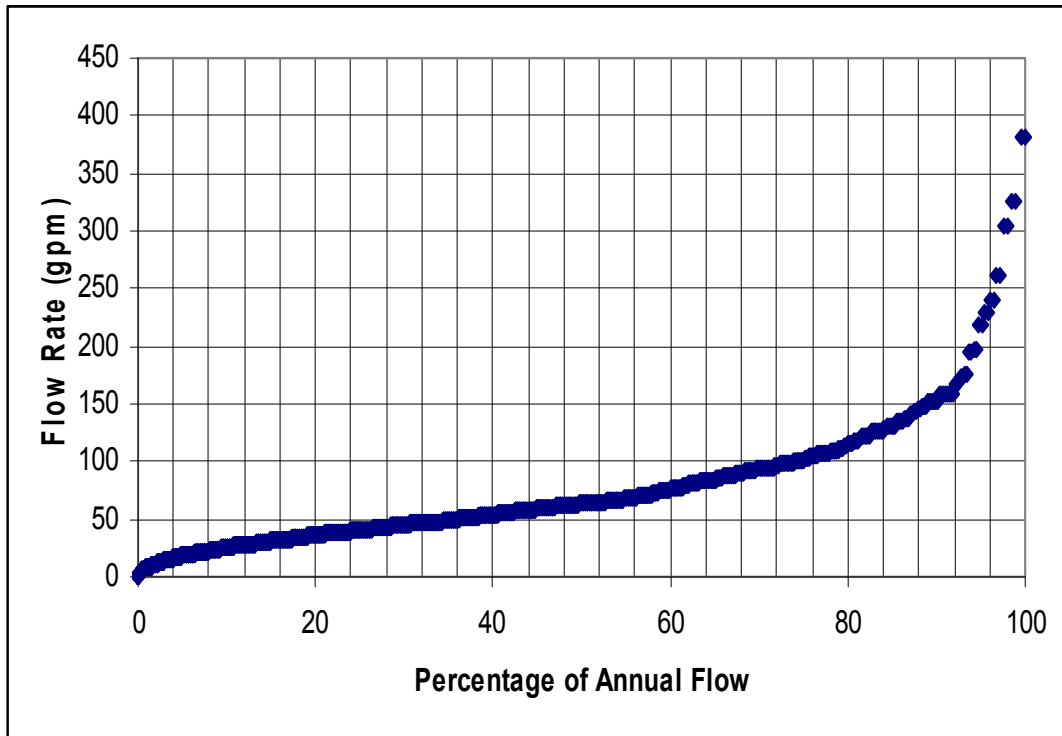

Figure 12. Percentage of Annual Flows at Tuscaloosa Test 0.9 ac Impervious Site (Pitt & Khambhammettu, 2006)

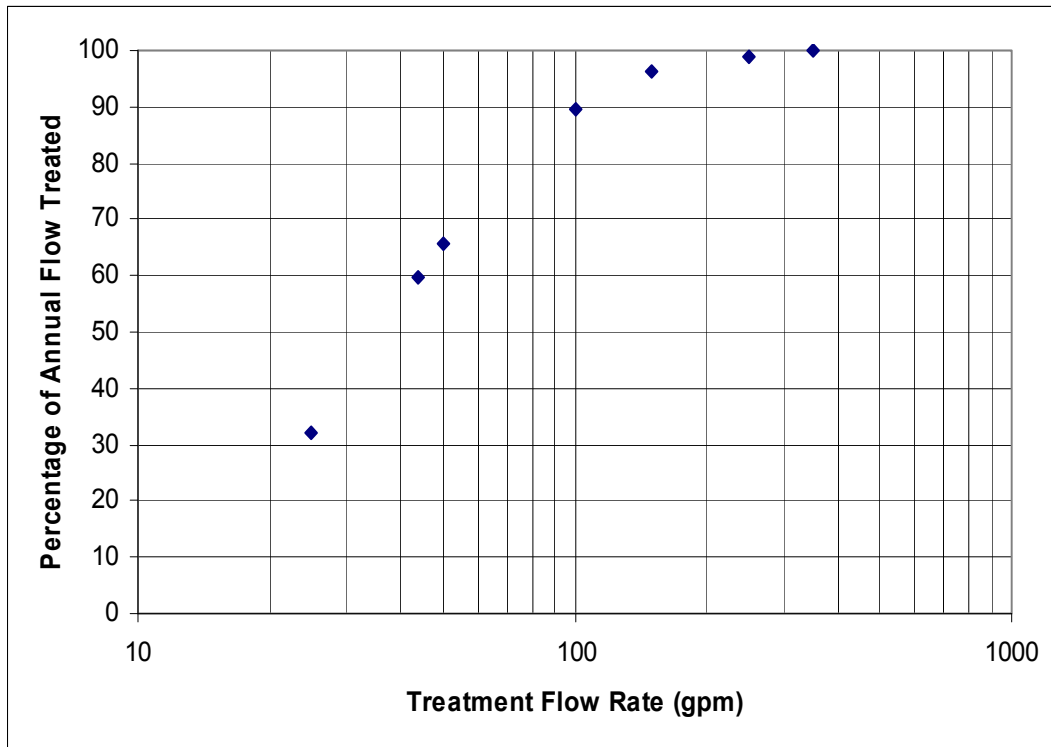

Figure 13. Treatment Flow Rate and Percentage of Annual Flow Treated for Tuscaloosa, AL, 0.9 acre impervious site (Pitt & Khambhammettu, 2006)

The Bama Belle/Riverwalk test site was also 0.9 acres in area, but it contained about 32% pervious areas. Therefore, the treatment flow rates were expected to be somewhat less than shown on Figures 12 and 13. The available treatment flow rate of the full-sized 6 filter module Up-Flo[®] Filter was expected to be able to treat more than 90% of the annual flows for a typical rain year, with less than 10% of the flows bypassing treatment.

3.9.6 Background Water Quality and Pollutants

The following figures summarize some of the water quality monitoring results from preliminary evaluations conducted at the site during a 0.9 inch rain on January 8, 2008 (full figures are in Appendix A with analysis for different rain events). The runoff samples were

obtained by manual grab sampling during storm events using a dipper sampler. Table 13 summarizes the results obtained during several other events before the filter was installed.

In order to capture any potential “first flush,” sampling personnel arrived at the site before the storm whenever a storm was forecasted. The sampling personnel remained at the site and periodically collected samples throughout the storm event. Samples were manually collected every 5 minutes for 30 minutes from the beginning of the rain event (6 bottles), followed by 15-minute interval samples for an hour (4 bottles), then 1-hour interval samples for 4 hours (4 bottles), then 6-hour interval samples for 24 hours (4 bottles), and finally 24-hour interval samples for as long as 96 hours, the longest rain monitored (4 bottles). Bacteria samples were collected separately from the other samples using sterilized bottles. The sampling intervals for the bacteria samples were every 30 minutes for 2 hours (4 bottles), 1-hour intervals for 4 hours (4 bottles), and then 6-hour intervals for 24 hours (4 bottles). If the rain stopped for more than an hour, the sampling was terminated and the collected samples were brought to the laboratory for analysis. Samples were analyzed for bacteria, pH, conductivity, turbidity, nutrients, chemical oxygen demand (COD), sediments, total dissolved solids (TDS), metals, and particle size distribution (PSD).

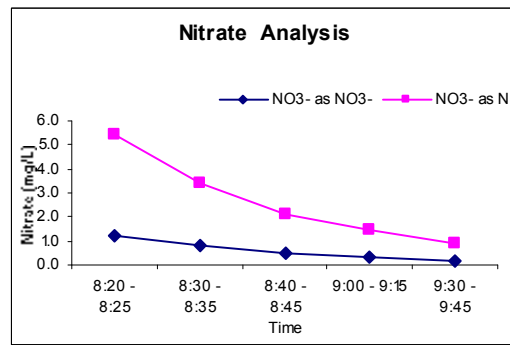
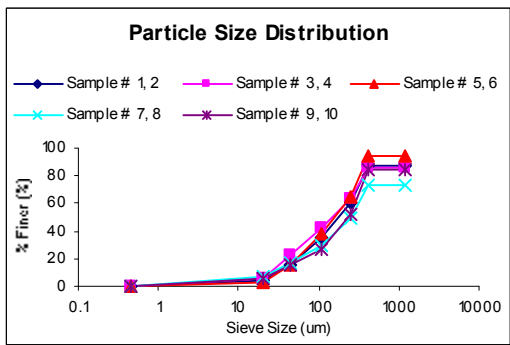
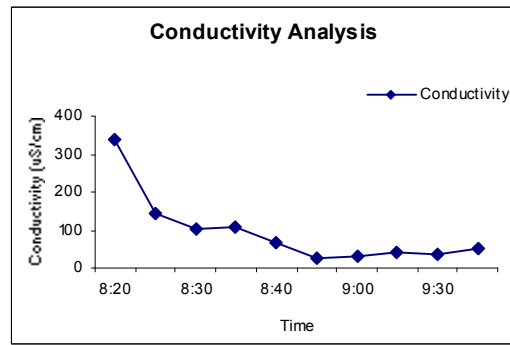
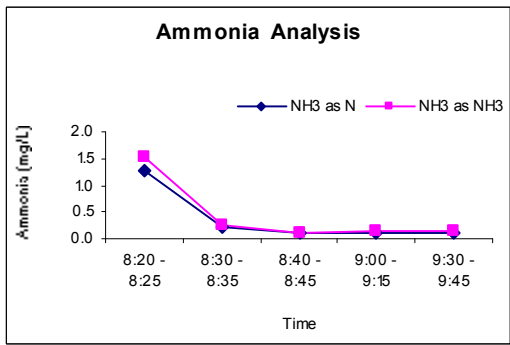
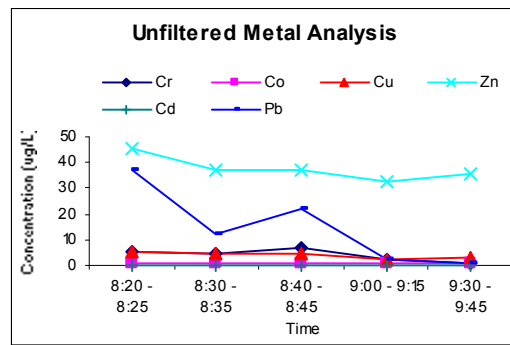
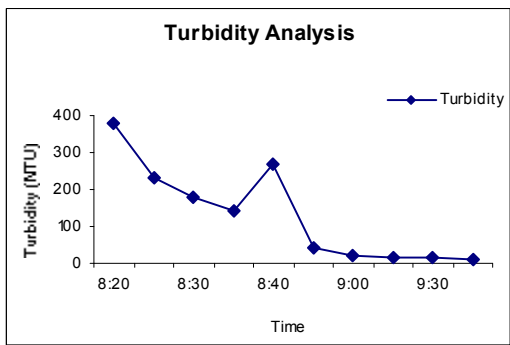
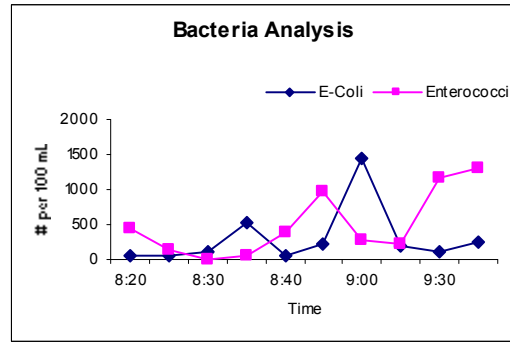
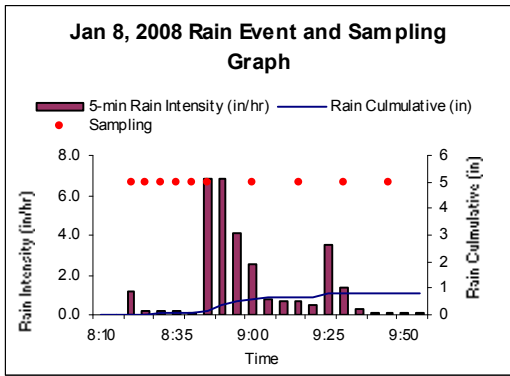

Figure 14. January 8, 2008 Stormwater Analysis at Bama Belle Site

Table 13. Median Stormwater Quality during Preliminary Bama Belle Site Monitoring

	Unit	Oct. 9, 2007	Oct. 22, 2007	Nov. 18, 2007	Jan. 8, 2008	Jan. 31, 2008	average	COV
Rain depth*	inches	0.7	0.02	0.1	0.9	1.2	0.7	0.64
Conductivity	µS/cm	120	150	65	70	100	100	0.35
Turbidity	NTU	65	80	23	100	300	115	0.95
Suspended solids	mg/L	83	55	25	250	140	110	0.72
Median particle size	µm	150	120	300	200	150	185	0.39
Total dissolved solids	mg/L	63	150	36	60	85	80	0.55
pH		6.7	6.7	6.2	5.8	6.9	6.5	0.07
COD (total)	mg/L	120	200	28	92	75	100	0.62
COD (filtered)	mg/L	60	130	8	48	10	51	0.97
Ammonia	mg/L as N	0.035	0.09	0.06	0.10	0.25	0.1	0.78
Nitrate	mg/L as N	0.50	0.5	0.9	2.1	1.9	1.2	0.65
Total Nitrogen (total)	mg/L as N	4.0	4.0	5.0	4.0	30	9.4	1.23
Total Nitrogen (filtered)	mg/L as N	2.5	3.0	2.0	2.0	8	3.5	0.73
Phosphorus (total)	mg/L as P	0.62	0.52	0.10	0.45	0.6	0.5	0.46
Phosphorus (reactive)	mg/L as P	0.34	0.20	0.09	0.10	0.10	0.2	0.65
Zinc (total)	µg/L	28	22	38	37	n/a**	31	0.24
Zinc (filtered)	µg/L	10	22	29	36	n/a	24	0.46
Lead (total)	µg/L	8	6.6	2.2	12	n/a	7.2	0.56
Lead (filtered)	µg/L	<1	0.8	0.7	<1	n/a	0.8	0.09
Copper (total)	µg/L	5.8	6.8	4.0	4.5	n/a	5.3	0.24
Copper (filtered)	µg/L	4.7	3.7	3.5	<1	n/a	4.0	0.16
Cadmium (total)	µg/L	0.05	0.04	0.035	0.04	n/a	0.0	0.15
Cadmium (filtered)	µg/L	0.045	0.04	0.020	0.04	n/a	0.0	0.31
Chromium (total)	µg/L	4.1	3.5	1.8	4.5	n/a	3.5	0.34
Chromium (filtered)	µg/L	0.8	1.3	0.5	<1	n/a	0.9	0.47
Cobalt (total)	µg/L	0.4	0.5	0.6	0.7	n/a	0.6	0.23
Cobalt (filtered)	µg/L	0.3	0.25	0.5	0.55	n/a	0.4	0.37
E. coli	#/100 mL	100	<10	40	300	250	140	0.84
Enterococci	#/100 mL	120	300	130	500	1000	410	0.80

* off-site rain gage; site rainfall not well known for these events

** n/a: not available

These initial site runoff characteristic data showed significant first-flush effects for turbidity and most of the other constituents, however; when bacteria were analyzed during later events, they showed an opposite pattern, with significantly increasing bacteria levels as the rain progressed. Therefore, the pavement and roadway were the likely sources for most of the sediment at the site, along with the metals and nutrients, but the soil in the surrounding landscaped areas were likely the major source of the bacteria.

The concentrations generally did not vary greatly between events, with COV values typically less than 0.5. When compared to national stormwater quality data, as presented in the 3rd version of the National Stormwater Quality Database (Pitt et al., 2008), the solids, COD, and nutrients were similar to concentration values reported elsewhere. However, the copper and zinc values were only about 1/5 the average concentrations reported nationally. The COV values were much less at the Bama Belle site for these constituents, likely because they were obtained from a single site over a relatively short period of time.

The conductivity, turbidity, and expected solids concentrations were moderate, while the median particle size was relatively large. Being mostly a paved area, the nutrient concentrations were relatively low. The heavy metal concentrations were typical for parking lots, and show that most of the zinc, cadmium, and cobalt were associated with the filtered fraction. However, the lead was mostly all particulate-bound, and the other metals and phosphorus and total nitrogen were more evenly split between the water and particulate phases, as expected for most stormwater.

Because of the strong first-flush characteristics at this site for most of the constituents, high-resolution sonde analyses supplemented with flow-weighted automatic samplers were used when evaluating the Up-Flo[®] Filter. In addition, both particulate and filterable forms of the

metals and nutrients were evaluated, as the filter was expected to perform differently for the different phases of the constituents.

3.10 Installation of Full Scale Filter

A 7-foot tall 4-foot diameter Up-Flo[®] Filter was installed at the Riverwalk parking lot near the Bama Belle on the Black Warrior River in Tuscaloosa, Alabama. The system received surface runoff from the parking lot, driveways, sidewalks, and a small landscaped area as described above. Installation was started on January 8, 2009 by Tuscaloosa Department of Transportation personnel. The following figures illustrate the installation process.



Filter before the installation



Removal of old inlet and excavation



Gravel to level elevation



Hoisting filter into cut



Filter placement in cut



Checking the level and elevation of the filter

Figure 15. Construction Pictures (Digging and placement of the filter)



Backfilled and connecting outlet pipe



Concrete pour for the effluent chamber



Leveling floor of effluent chamber



Outfall to Black Warrior River



Effluent sampling box installation



Top of the sampling box construction

Figure 16. Construction Pictures (Pipe connection and effluent sampling box construction)



Filter inlet formwork



Inlet completed



Asphalt repair



Seeding and erosion control



Final site clearing



Completed installation

Figure 17. Construction Photographs (Inlet Installation and Completion)

3.11 Controlled Tests

3.11.1 *Summary*

The controlled performance monitoring was conducted at the Riverwalk parking lot near the Bama Belle in Tuscaloosa, Alabama, in late summer of 2009. The first flow tests were conducted for the purpose of determining the hydraulic capacity and the pollutant removal capabilities in a full-scale field installation under controlled conditions. There were twelve different flow tests conducted using different flow rates for each media. In these tests, the filtration rate of the CPZ Mix™ filter media, a proprietary mixture of bone char activated carbon, peat moss, and manganese coated zeolite as well as the sand media were evaluated. Based on results of prior lab scale testing, the mixed media was expected to have high pollutant removals at relatively high filtration rates. The Up-Flo® Filter was fitted with two media bags for each of the 6 chambers, for a total of 12 bags, as well as the flow distribution material above and below the media.

3.11.2 *Controlled Flow Test Preparation*

The controlled flow tests began with the cleaning of the filter chamber and placement of new filter bags. This involved washing all material into the sump and then vacuuming the sump material.



Debris in filter prior to tests



Filter cleaning



Cleaned filter interior



Media is installed with green base



Cap installed over the draindown opening for maximum capacity determination



Completed installation

Figure 18. Controlled Flow Test Preparation

3.11.3 Methodology for the Evaluation of Filtration Rate

The flow tests were conducted in the field with the cooperation of the Tuscaloosa Department of Transportation by using a pump to enable the use of the river water as the influent water. The river water was pumped to a large plastic drum that had two valued outlets that controlled the flow rate to the filter. The water was discharged to the gutter above the filter inlet. In order to adjust the flow rate for the tests, the water was discharged to a plastic tray with an 11 gallon volume marked capacity (Figure 19). The time needed to fill the tray tank was timed with a stop watch to determine the flow rate. Each flow rate was measured 5 times to determine the variation in the flow during each test. Figures 20 to 22 show a flow vs. head graph developed during three of the tests.



River water is pumped into the plastic flow splitter barrel



Pumped river water is discharged from splitter barrel to the 11 gallon plastic tray to manually measure the flow

Figure 19. Flow Rate Measurement and Controlled Flow Splitter Setup

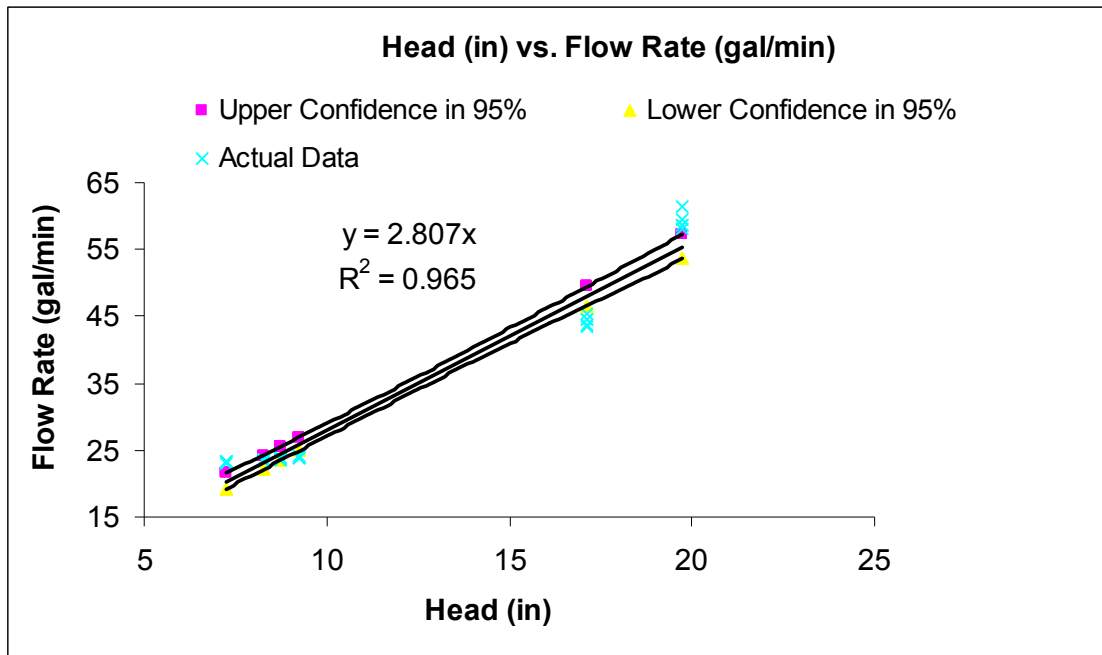

Figure 20. Flow vs. Head Graph for the Mixed Media, showing highly repeatable measurements (total filter surface area: 9 ft²)

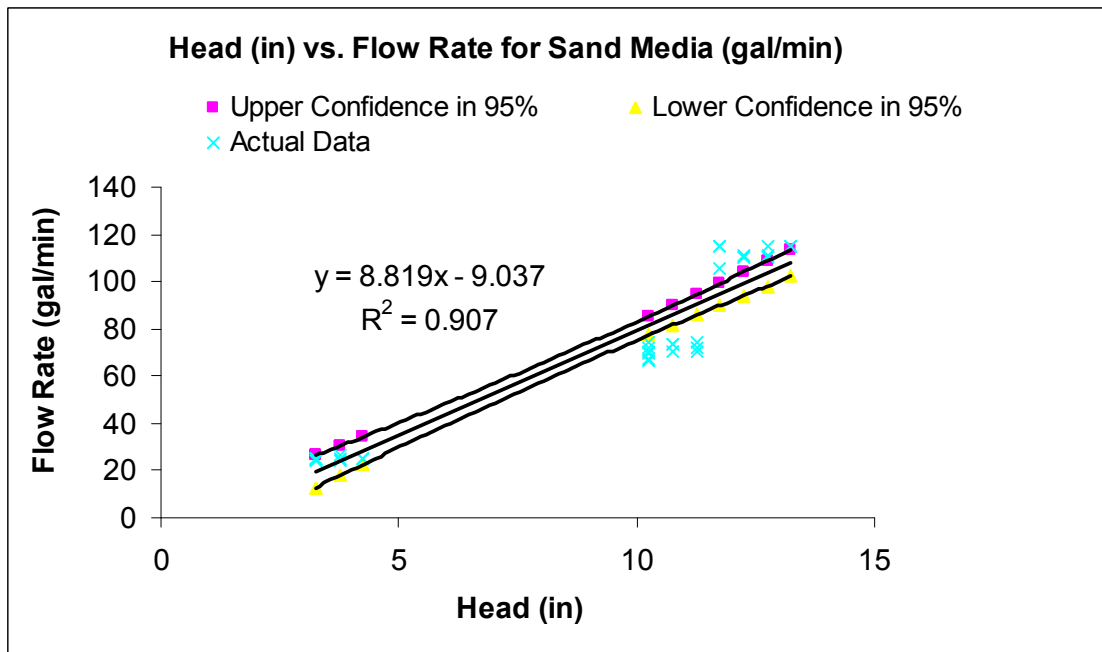

Figure 21. Flow vs. Head Graph for Sand Media (total filter surface area: 9 ft²)

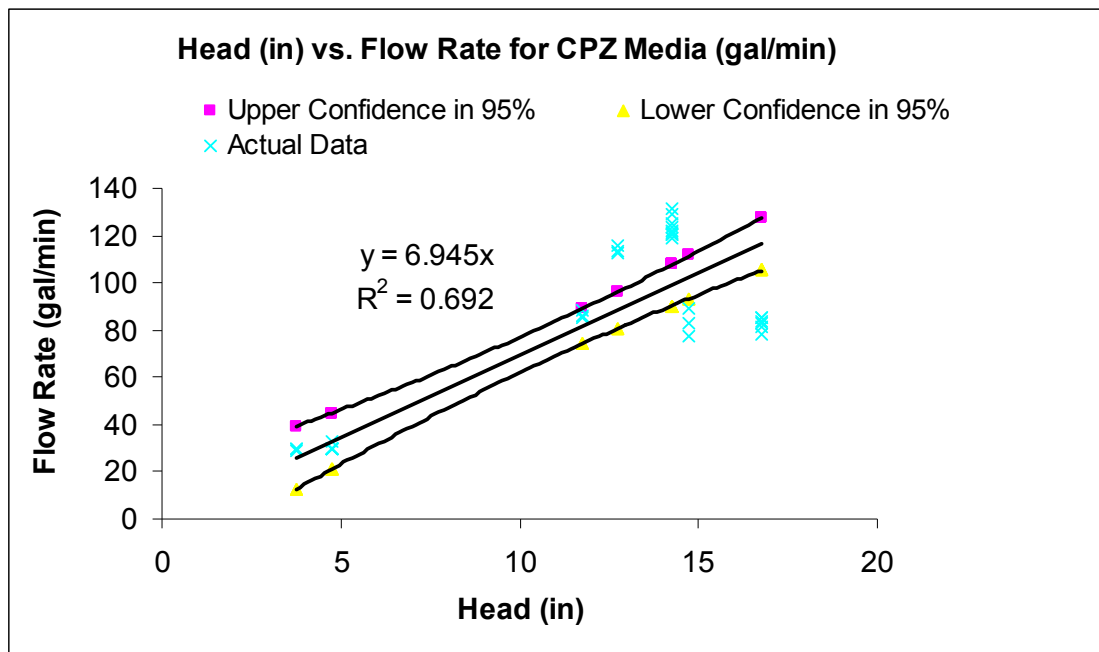

Figure 22. Flow vs. Head Graph for CPZ Media (total filter surface area: 9 ft²)

3.11.4 *Controlled SSC Removal Tests*

3.11.4.1 Introduction

Controlled tests could measure the filter behavior under specific conditions. However, the major disadvantage of controlled testing is that it is difficult to simulate the rapidly variable flows and stormwater characteristics that occur during natural conditions. The use of ground silica available from the U.S. Silica Co., had enabled more accurate filter tests under controlled conditions, especially for fine particle sizes. The removal capability of the Up-Flo[®] Filter for sediments and the other pollutants was measured during actual storm events, as shown in Chapter 5.

3.11.4.2 Particle Size Distribution of Tested Media and Test Sediment

The test sediment in the stormwater stimulant was based on the following mixture: Sil-Co-Sil 250, Sil-Co-Sil 106 (both from U.S. Silica Co.), and coarse and fine concrete sands. The mixture was made by mixing the four components with different ratios (fine sand: coarse sand: Sil-Co-Sil 106: Sil-Co-Sil 250 = 5: 17: 70: 8 by mass) to obtain a relatively even particle size distribution representing the range from about 20 to 2,000 μm . This mixture was not intended to represent actual stormwater (which usually has a smaller median size), but to ensure sufficient amounts of large particles so they could be accurately monitored to quantify their removal. All of the results of these controlled tests were presented based on many narrow particle size ranges, so they could be applied to any expected particle size distribution of the flowing water. Since the samples were all analyzed using sieves and the Coulter Counter, these results were much more useful than if single SSC analyses were conducted. If a single analysis was conducted, then the PSD of the challenge water would have to match the stormwater PSD, a difficult objective given the highly variable particle size characteristics of stormwater. Figure 23 shows the particle size distribution of the four individual components used to create the test mixture and Figure 24 shows the particle size distribution of the test mixture.

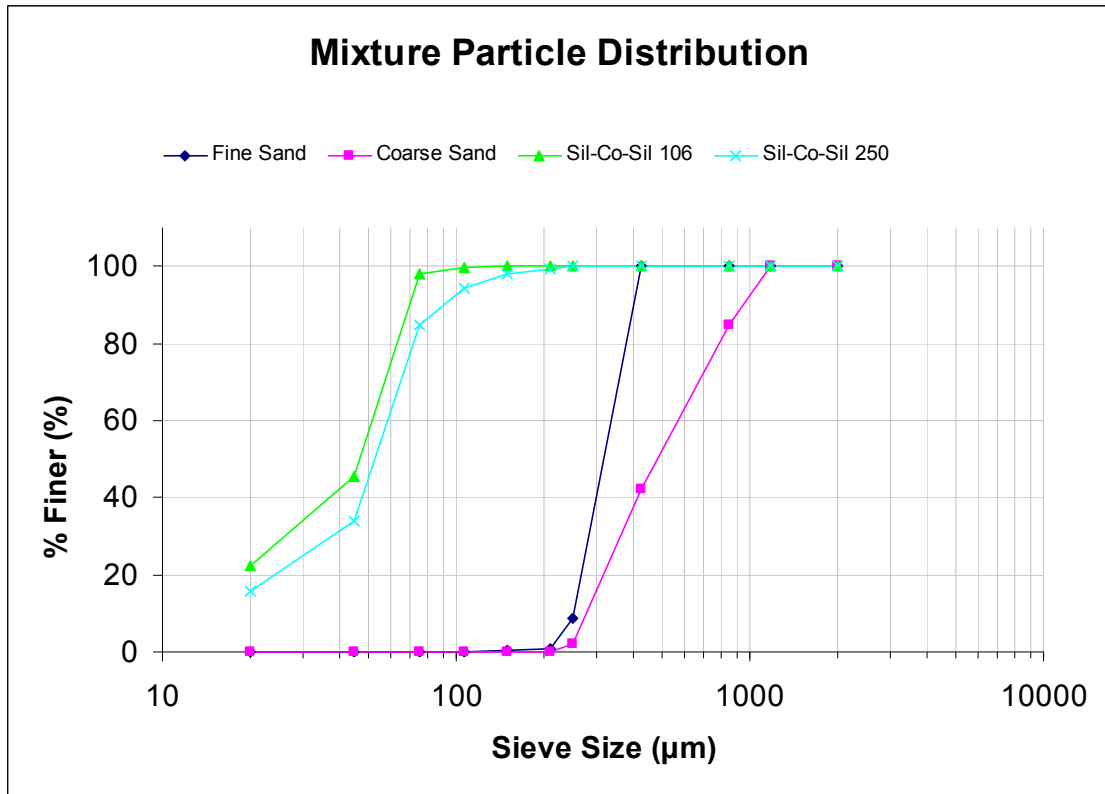

Figure 23. PSD for the Four Components

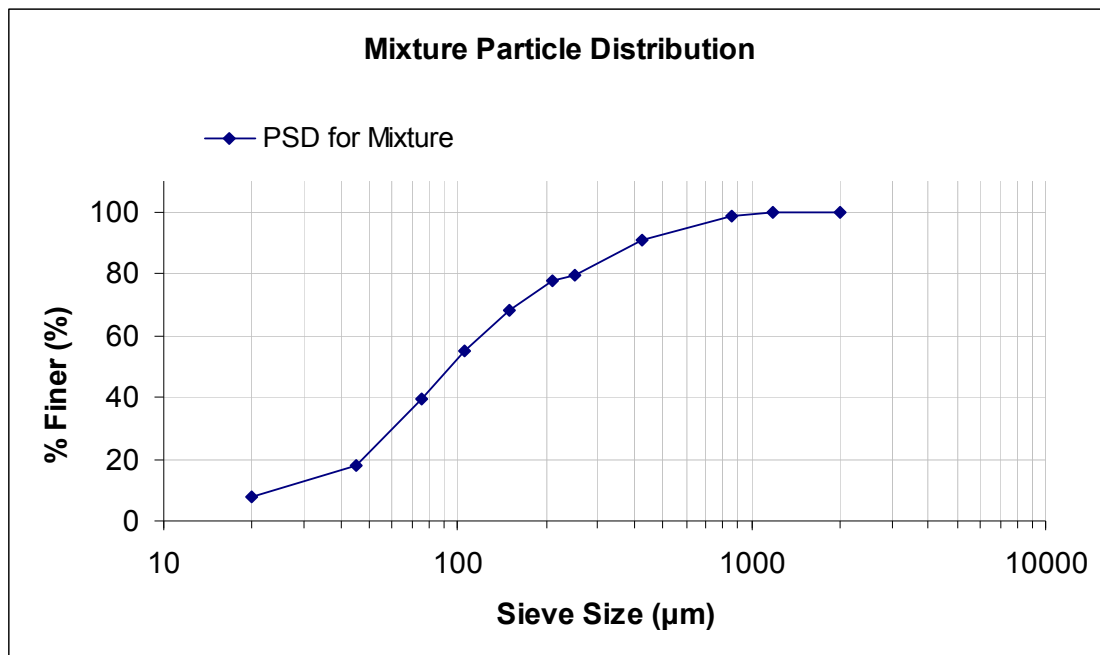

Figure 24. PSD for the Mixture used for Flow Test

3.11.4.3 Test Methodology for Controlled Sediment Capture Tests

The tests described below used several known concentrations of particulate solids and influent flow rates (approximately 25 GPM, 75 GPM, and 150 GPM). The solids mixture was made up of a specific combination of ground silica and sieved sand, covering the particle size range from about 0.45 µm to 2,000µm. Each experiment was conducted for 30 minutes, during which time measured aliquots of the dry sediment were constantly poured into the pumped influent “river flow” from the Black Warrior River. River water was also collected before any sediment was added to measure the background solids in the test water. Effluent samples were collected using a dipper grab sampler every 1 minute and composited in a churn sample splitter during the 30-minute test period, after a 10 minute delay to enable steady-state conditions to be

established. Using the churn splitter, two samples of 1000 mL each were placed in sample bottles for duplicate laboratory analyses for each test.

In preparation for the tests, test sediment portions were pre-weighted in many 50 mL polyethylene bottles. The sediment was manually fed into the influent water over the whole period of each experiment, according to the desired particulate solids concentration for the specific flow rate for each test. This method ensured that all of the sediment and all particle sizes entered the test chamber. Water depth readings of the water levels were also taken during each experiment to determine the head loss for the Up-Flo[®] Filter for each flow rate. Also, after completion of each experiment, multiple flow and depth readings were taken to determine the final flow rate and available head to detect any change in filtration rate during the test.

As noted, Black Warrior River water was used as the influent water source. Using a pump located on the Bama Belle dock, the river water was pumped to the flow splitter barrel with the flow controlling outlets. For each flow rate, the flow measurements were repeated five times.

During the first tests using the CPZ[™] mixture medium, four different influent sediment concentrations were tested: 50mg/L, 100mg/L, 250mg/L, and 500mg/L. The influent flow rate was calculated to average 24 gallon per minutes and the standard deviation was 0.3 gpm.



Sediment mixture is added to the flow



Samples are taken from the effluent box



Sample splitting using churn splitter



Flow is discharging to the inlet

Figure 25. Controlled Sediment Capture Test

3.11.4.4 Sample Handling and Analysis

A total of 8 separate controlled experiments were conducted. Total solids, suspended sediment concentration (SSC), total dissolved solids (by difference), and particle size distribution (PSD) analyses were carried out for each sample and its duplicate. A total of 180 samples were analyzed during these controlled tests. Before conducting the analyses, each sample was split into 10 equal volumes of about 100 mL each using a USGS/Dekaport cone splitter, as shown in Figure 26. These split subsamples were analyzed for total solids, suspended sediment, and PSD.

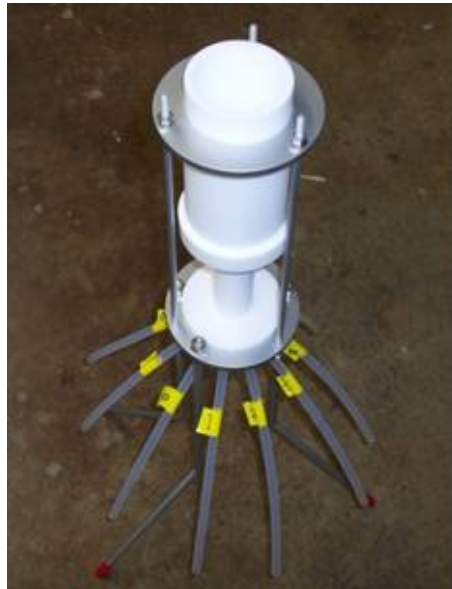

Figure 26. USGS/Dekaport Teflon™ Cone Splitter

3.11.4.5 Laboratory Procedure for the Solids Analysis (Flow Chart in Figure 27)

1. Ten 250 mL capacity graduate cylinders (short versions) are placed under each tube of the splitter in order to measure the volume of each subsample (needed for SSC calculations).

2. Nylon screening material with 1180 μm openings is used at the top of the cone splitter to capture large particles such as leaves, twigs and insects (these materials also are dried, weighed and chemically analyzed). This screening material is washed and dried completely before use. After weighing the aluminum dish and screening, 1 L bottle sample water is carefully poured to the splitter. The initial volume is noted for each split. The sample bottle then is then rinsed and poured into the splitter several times to ensure that the large particles that tend to catch near the bottle lip are rinsed into the splitter. Then the additional water added is noted in order to adjust the calculated concentrations.
3. The unfiltered water subsamples are used for total solids analyses, so the total sample particulate content less than 1180 μm can be determined. The weight of the material captured on the 1180 μm screen is included when calculating the total solids concentration of the sample.
4. Two subsamples are poured through a 3-inch stainless steel Tyler #60 sieve to remove particles larger than 250 μm from the subsample. One of these are used for solids analyses to determine the fraction of the particle solids having particles smaller than 250 μm , while the other is used for the Coulter Counter particle-size-distribution analyses.
5. One subsample is poured through a 3-inch stainless steel Tyler #140 sieve to remove particles larger than 106 μm from the subsample. The sample is used for solids analyses to determine the fraction of particles smaller than 106 μm .
6. The initial particle size distribution is created using the software provided by Coulter that overlaps the different results from the different Coulter Counter aperture tubes. Each aperture tube can quantify particles in the range of approximately 2% to 60% of the aperture size (e.g., 30 μm tube – 0.6 μm to 18 μm ; 140 μm tube – 2.8 μm to 84 μm ; 400

µm tube – 8 µm to 240 µm). Each of the tubes substantially overlaps the adjacent tube providing sufficient duplication of particle diameters for the software overlap. Three-inch stainless steel Tyler sieves are used to pre-sieve the subsamples before analyses by each aperture to minimize clogging; the sieve size selected is the smallest commercially-available sieve that exceeds the maximum analytical range of each tube, while still being smaller than the tube aperture itself (e.g., 30-µm tube – 20-µm sieve [Tyler #625], 140-µm tube – 106-µm sieve [Tyler #150], 400-µm tube – 250-µm sieve [Tyler #60]). The sample is pipetted through the sieve and directly into the Coulter Counter vessel. Each aperture tube analysis is repeated 2 times and the results averaged.

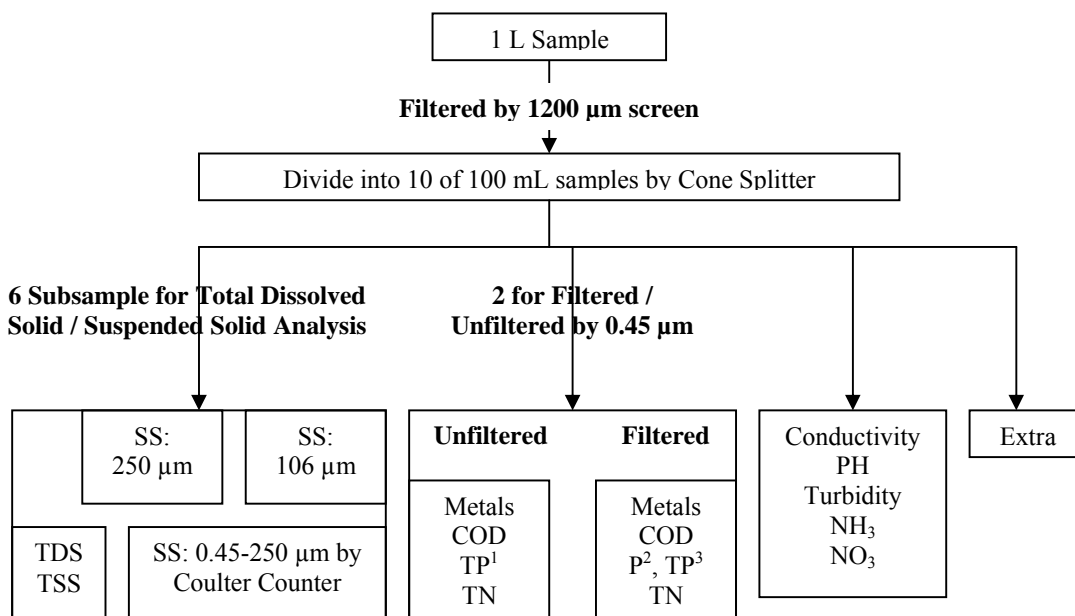

- 1) Total Phosphorus
- 2) Dissolved Orthophosphate
- 3) Total Dissolved Phosphorus
- 4) Total Dissolved Phosphorus is only analyzed for the samples collected after March 4, 2011.

Figure 27. Flow Chart for the Analysis

3.12 Actual Field Monitoring

Field monitoring was conducted in order to determine the removal capacity of pollutants such as metals, chemicals, sediments, and bacteria during actual rain events, with the experimental incorporating criteria components from the different protocols.

3.12.1 *Sampling Location*

Flow and water quality were monitored to quantify the water quality control benefits that occurred due to treatment by the Up-Flo[®] Filter. The sampling locations were at the influent and at the effluent of the filter. The influent sample was collected from an influent sample tray that receives cascading influent water from the parking lot gutter. This tray contained the intake of the automatic sampler and the continuous water quality sonde. The cascading water onto the sampler intake ensured a completely mixed sample. The effluent sampling location was located where the effluent from the filter enters a sampling chamber. Again, the water cascaded into a sampling tray that contained the automatic sampler intake and a continuous water quality sonde. The effluent chamber was a concrete box, located 8 feet in horizontal distance and 1 ft in vertical distance from the outlet of the Up-Flo[®] Filter. The effluent sampling location also had a completely mixed sample caused by the turbulence of the cascading water during the 1 ft drop from the outlet pipe into the sample tray.



Figure 28. Influent Sample is Collected in the Sample Tray

3.12.2 *Pollutant Constituent Selection*

The constituents analyzed as part of the rain event testing include:

Primary Constituents:

- Suspended sediment concentration (SSC)
- Total suspended solids (TSS) $> 0.45 \mu\text{m}$ ($< 75 \mu\text{m}$ particles from the complete PSD and SSC analysis and by traditional “shake and pour” splitting of samples into graduated cylinders before filtration by $0.45 \mu\text{m}$ membrane filters)
- Total Solids (TS) (by summation)
- Total Dissolved Solids (TDS) ($< 0.45 \mu\text{m}$ particles)
- Particle Size Distribution (by sieves and Coulter Counter)

Secondary Constituents:

- Total and filtered heavy metals (Cadmium, Chromium, Copper, Lead, and Zinc)
- Total and filtered Chemical Oxygen Demand (COD)
- Total and filtered Phosphorus (total phosphorus, dissolved total phosphorus)
- Dissolved orthophosphate
- Total and filtered Nitrogen
- Ammonia
- Nitrate
- Bacteria (E. Coli, Total Coliforms, and Enterococci)
- Conductivity (continuous and for samples)
- pH (continuous and for samples)
- Turbidity (continuous and for samples)
- Temperature (continuous and for samples)
- Dissolved oxygen (continuous)
- Oxygen Reduction Potential (ORP) (continuous)

The constituents were selected based on the TARP and TAPE protocols and previous research. Table 14 summarizes the Analytical methods used as well as the detection limits or ranges of each constituent.

3.12.3 *Phosphorus Testing Procedures*

Additional phosphorus testing for the total dissolved phosphorus was conducted after the March 4, 2011 rain event as phosphorus became recognized as an important current issue for states, including Maine, New York, Virginia, and Minnesota (MDM, 2010; MSM, 2007). These states have aggressively added phosphorus to the primary pollutants for their new regulations.

However, there has been some confusion pertaining to the “forms” of phosphorus to be analyzed. The EPA describes the various and most typical forms of phosphorus including 1) suspended and dissolved orthophosphate, 2) total phosphorus consisting of orthophosphate, condensed phosphate, and organic phosphate, and 3) total dissolved phosphorus which is the dissolved portion of the total phosphorus consisting of orthophosphate, condensed phosphate, and organic phosphate (EPA, 2011). The EPA also identified three different analytical procedures to analyze the three important forms. The first method is to measure only the orthophosphate (which can be further distinguished by the total orthophosphate (unfiltered) and the dissolved orthophosphate (filtered) by simply filtering the sample). The second and third methods measure the all forms of phosphorus by “digesting” (heating and acidifying) the sample to convert all the other forms to orthophosphate. Dissolved (filtered) orthophosphate and total phosphorus were measured for all of the collected samples, however; the total dissolved phosphorus test was conducted only for samples collected after the March 4, 2011 rain event.

Table 14. Analytical Methods and Detection Limits/Ranges

Constituents	Analytical Methods	Detection Limits/Ranges
SSC	ASTM D3977-97B	N.A.
TSS	EPA Method 160.2	N.A.
TS	EPA Method (by summation)	N.A.
TDS	EPA Method 160.2	N.A.
Cd (outside laboratory)	EPA-600/3-83	0.005 mg/L
Cr (outside laboratory)	EPA-600/3-83	0.02 mg/L
Cu (outside laboratory)	EPA-600/3-83	0.02 mg/L
Pb (outside laboratory)	EPA-600/3-83	0.005 mg/L
Zn (outside laboratory)	EPA-600/3-83	0.02 mg/L
COD	Hach 8000 (EPA Approved)	3 to 150 mg/L
Total P as PO ₄ ³⁻	Hach 8190 (Standard Method)	0.06 to 3.50 mg/L
Total Dissolved P as PO ₄ ³⁻	Hach 8190 (Standard Method)	0.06 to 3.50 mg/L
Dissolved Orthophosphate as PO ₄ ³⁻	Hach 8048 (Standard Method)	0.02 to 2.50 mg/L
Total/Dissolved N as N	Hach 10071 (EPA Approved)	0.5 to 25 mg/L
Ammonia as N	Hach 10023 (EPA Approved)	0.02 to 2.5 mg/L
Nitrate as NO ₃ ⁻ -N	Using Accu Vac Ampuls (EPA Approved)	0 to 5.0 mg/L
Bacteria	IDEXX Method	<1, 1-2419.6, >2419.6
Conductivity (laboratory)	EPA Method 120.6 (Standard Method 2510.B.)	0 to 199,900 μS
pH (laboratory)	EPA Method 150 (Standard Method 4500-H ⁺ .B.)	-2.00 to 19.99
Turbidity (laboratory)	EPA Method 180.1 (Standard Method 2130.B.)	0 to 4000 NTU
Temperature (laboratory)	EPA Method 170.1 (Standard Method 212)	-5.0 to 105.0 °C

3.12.4 Sampling Process (Flow Chart in Figure 30)

Each sample container (one for the influent and other for the effluent) had a maximum capacity of 15 L and the collected volume varied depending on the storm conditions. If more than about 2.5 L sample was collected, the sample was split first using the churn splitter (Figure 29) to obtain an approximate volume of 1 L into a clean bottle. Approximately 1 L of sample was separated into a 100 mL capacity graduate cylinder by the shake and pour method from the

above obtained 1 L bottle for the traditional TSS analysis. The remaining sample was then separated into 10 subsamples by the USGS/Dekaport Cone Splitter. If the full sample volume was less than about 2.5 L, about 100 mL sample was directly taken into the 100 mL graduated cylinder by the shake and pour for the TSS analysis and the remaining sample was directly separated by the Cone Splitter into 10 subsamples. Subsampling was also required to measure the volume of water required for the calculation of the PSD analyses.

1. Total sample volume was measured in the 15 L sample container. If the total sample volume exceeds about 2.5 L, the churn splitter was used to remove approximate 1 L. Then about 100 mL of sample was taken in the 100 mL capacity graduate cylinder. Initial volume was recorded and the sample was stored for the TSS analysis. If the total sample volume was less than about 2.5 L, about 100 mL of the sample was separated directly by the shake and pour into the 100 mL capacity graduate cylinder. Initial volume was recorded and the sample was stored for the TSS analysis.
2. 250 mL graduated cylinders were placed at each outlet of the cone splitter.
3. Nylon screening material with 1180 μm openings was used at the top of the cone splitter to capture large particles such as leaves, twigs and insects (these materials are dried and weighed and chemically analyzed also). This screening material was washed and dried completely before use. The aluminum dishes and the screening material were weighed after cleaning and drying. 1 L bottle sample water (if the total volume is more than 2.5 L) or directly from the 15 L sample container (if the total volume is less than 2.5 L) was carefully poured to the splitter.

4. Initial volumes of each subsamples were measured and these values were used for the calculation of soil concentrations (especially for SSC, TS, and TDS).
5. Subsamples were transferred into the clean bottles for further analyses.



Figure 29. Sample Splitting Using Churn Splitter

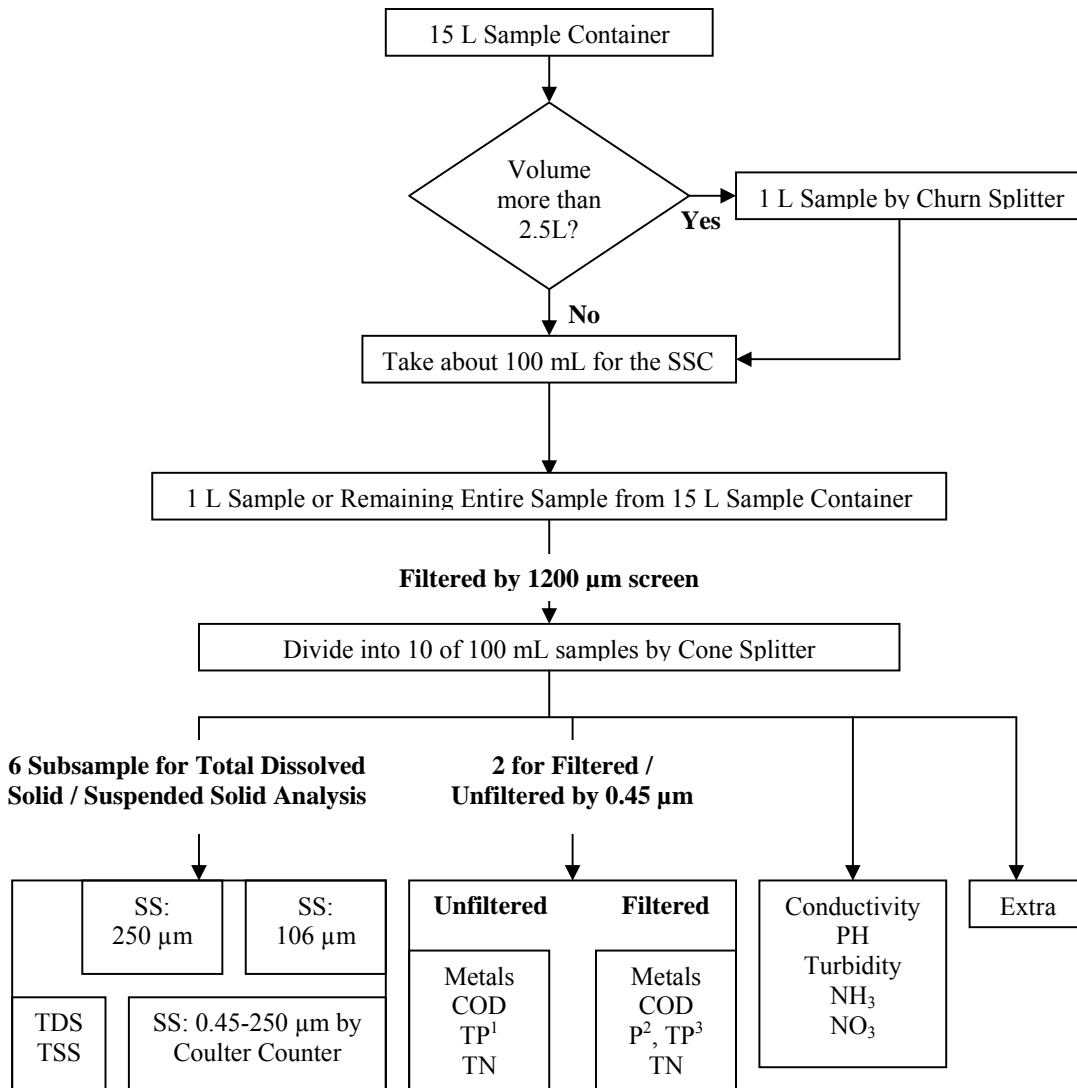

- 1) Total Phosphorus
- 2) Dissolved Orthophosphate
- 3) Total Dissolved Phosphorus
- 4) Total Dissolved Phosphorus is only analyzed for the samples collected after March 4, 2011.

Figure 30. Flow Chart for the Field Sample Analysis

3.12.5 *Suspended Sediment Concentration (ASTM, 1997)*

1. 0.45 μm pore size glass fiber filter paper with wrinkled side up is placed on the filtration apparatus using a pair of tweezers. Vacuum is applied and the filter paper is washed three times with about 20 mL of DI water. After continuous suction, all traces of water are filtered through the filter paper. The filter paper is removed and placed on an aluminum dish which was washed before with DI water. The aluminum dish is placed in the oven and left for complete evaporation of water at 105°C for approximately 24 hours.
2. The filtration apparatus was washed before and after washing every filter paper.
3. After 24 hours, the aluminum dishes are removed from the oven and placed inside desiccators.
4. The complete split subsample (approximately 100 mL) from the cone splitter is then filtered thru the cleaned and weighed filter. The filtered water volume is measured directly during the subsampling process and the filter is dried and weighed, as described below.
5. In addition to the sieve analysis, particle size distributions are measured using the Coulter Counter for the smaller particles.

3.12.6 *Dissolved Solids*

The crucibles are properly washed using DI water. They are then placed in the oven at 105°C for approximately 24 hours. The crucibles are removed from the oven after complete evaporation of water and placed in desiccators for cooling, and then weighing.

3.12.7 *Procedure for Suspended Sediment Solids Analysis (Chan, Li, & Stenstrom, 2008; Clark & Pitt, 2008; Clark & Siu, 2008; J. R. Gray, Glysson, Turcios, & Schwarz, 2000)*

1. The aluminum dish with the filter paper is weighed.
2. The filter paper with the wrinkled side facing up is placed on the filtration apparatus. Suction is applied and the filter paper is made wet using a small volume of DI water to seat it.
3. The volume of the sample water used for analysis is measured accurately in the prior subsampling process.
4. The water is stirred well and transferred onto the filter paper at continuous suction. A small volume of DI water is used to wash down all the solids in the sample bottle on the filter, after the filtered water volume is measured.
5. The filter is washed with three successive 10 mL volumes of DI water. The suction is continued until visually all the water is filtered out.
6. The filter paper is removed from the filtration apparatus and replaced in the same aluminum dish.
7. The aluminum dish along with the filter paper is placed in the oven at 105°C for approximately 24 hours.
8. The aluminum dish is cooled in the desiccators and then weighed.

Suspended Sediment Concentrations are calculated by the following equation.

$$\text{Suspended Sediment Concentration} = (\text{Weight of aluminum dish before filtration (mg)} - \text{Weight of aluminum dish after filtration (mg)}) / \text{Volume (L)}$$

3.12.8 *Procedure for Total Dissolved Solids Analysis (Standard Method, 2005)*

1. Cleaned crucibles are removed from the desiccators and weighed.
2. After the filtration, the water which was filtered by the 0.45 µm filter is transferred into the crucibles.
3. The flask was washed with DI water and transferred into the crucibles to make sure all the solids are transferred into the crucible.
4. The crucibles are placed in the oven at 105°C for approximately 24 hours.
5. The crucibles are removed after 24 hours and placed in the desiccators for cooling.
6. After cooling, the crucibles are weighed.

Total dissolved solids are calculated by the following equation.

Total Dissolved Solids = (Weight of Empty Crucible (mg) – Weight of Crucible after evaporation (mg))/ Volume (L)

3.12.9 *TSS and SSC Procedures*

Three different laboratory methods have been commonly used to quantify the amount of solids in the stormwater. The three methods are EPA's TSS Method 160.2 (EPA, 1999), APHA's Standard Method TSS Method 2540 D (APHA, 1995), and ASTM's SSC Method D3977-97B (ASTM, 1997). All three methods are similar in terms of filtering, drying, and weighing the amount of residue left on the filter, however; the main difference is associated with the sub-sample preparation and the amount of water used for the filtration. The EPA's Method (1999)

does not specify the amount of water used (but it must be known) since the filtration rate is the determining factor (EPA, 1999). The subsample is obtained by vigorously shaking the sample contained and pouring the subsample into a graduated cylinder. The APHA's Method (1995) does not specify the volume of water to be used either, however; the sub-sample is specified to be taken using a wide-bore pipette mid-depth and midway between the wall and vortex while stirring with a magnetic stirrer. The ASTM's Method (1997) specifies the use of the whole original water samples without sub-sampling (ASTM, 1997). EPA specifies the filters used for the analysis as glass fiber filter such as Millipore AP-40, Reeves Angel 934-AH, Gelman type A/E, or equivalent (EPA, 1999). APHA's Method and ASTM's Method do not specify the filter, but specify the use of a glass fiber filter (APHA, 1995; ASTM, 1997). The use of the different method can result in significantly different final values (Clark & Siu, 2008; Glysson, Gray, & Conge, 2000). According to Glysson and Gray (2002), computation of sediment loads using SSC data produced smaller variations than using TSS data and that the TSS data shown negatively bias when compared to SSC data (Glysson & Gray, 2002). Clark and Siu (2008) concluded that the SSC method has advantages over the TSS method in terms of accuracy and preciseness, however; they recommend analyzing sediments in both methods in order to compare the historical TSS data with the current research results (mostly analyzed by SSC method), as well as PSD for determining the appropriate correlation between TSS and SSC (Clark & Siu, 2008).

3.12.10 *Sampling Effort*

The actual rain event monitoring effort of the full-scale Up-Flo[®] Filter started during mid-summer of 2010. Automatic samplers were used to collect the water samples using flow-weighted composite sampling procedures. According to the TARP and TAPE protocols, a rainfall event must have the following characteristics to be considered a qualified sampling event:

- At least 12 events are to be analyzed having a minimum rain depth of 0.1 inches
- Minimum duration of dry period between the individual events is 6 hrs
- Automatic samplers are used to collect samples, except for constituents that require manual grab samples
- The flow-weighted composite samples must cover a minimum of 70% of the total storm flow, including as much of the first 20% of the storm as possible
- Rainfall monitoring intervals should be 15 min or shorter period
- Quality control tests, including precision, accuracy, representativeness, comparability, completeness should be performed. Field blank and replicate samples should be collected in order to achieve the quality control goal.

The sampling and analysis protocol includes sampling as many of the rains that occur during the sampling time frame as possible in order to enable accurate mass balance calculations. The water quality and discharge data collected were used to calculate mass loadings for the various constituents going into and out of the Up-Flo[®] Filter. These mass loadings were used to calculate the removal rates of the Up-Flo[®] Filter, including its ability to retain pollutants, in addition to analyzing the material captured in the sedimentation sump (analyzed separately after the monitoring period).

3.12.11 *Water Quality Data Collection Method*

Flow and water quality monitoring were conducted using completely automated techniques to minimize labor and errors inherent in manual sampling techniques. Flow was monitored on a continuous basis, along with continuous measurements of some water quality constituents using the sondes, and samples for water quality analyses were collected during the runoff events.

Samples were collected using flow-weighted composite sampling during the events for selected analyses to indicate performance for varying storm conditions. Sample composites were combined based on the flows associated with each subsampling increment automatically by the sampler. In all cases, data was collected for as much of the complete storm period as possible.

During the period of monitoring, the equipment was checked for proper functioning and sampling. The sampler intake lines were inspected by Department of Civil, Construction, and Environmental Engineering personnel at the University of Alabama to verify they were not inundated with sediment or other debris.

3.12.12 *Monitoring Equipment*

Sampling at the influent and effluent locations were conducted using two ISCO 6712 automatic samplers, and the flow rates were measured using an ISCO 4250 area-velocity meter, which was also capable of measuring the stage of the flow. All the sampling equipment was calibrated during the controlled flow tests.

The rainfall intensity and depth were measured using a standard tipping bucket rain gauge as well as the small totalizing rain gauge for the verification of accuracy. The main sampling location was located close to moderate sized trees, and the main rain gauge was likely affected by their presence. Another tipping bucket rain gauge was operated on the roof of the Civil Engineering building on campus 1.75 miles away. Runoff flow rate was the primary measure affecting performance and was calibrated during the controlled test.

YSI 6600 water quality sondes were used to measure continuous water quality data for temperature, dissolved oxygen, pH, ORP, turbidity, conductivity, and water depth. The sondes were installed in the sampling trays at the influent to the Up-Flo[®] Filter and in the outlet box. After the samples were retrieved for delivery to the laboratory, the sampling tray was emptied

into the filter sump and the influent sonde was moved into a perforated pipe in the filter sump to continuously measure water quality between events in the standing sump water.

3.12.13 *Pre-Sampling Site Hydrology Monitoring and Programming of Automatic Samplers*

Nine rainfall events were monitored from January 20 to March 21, 2010 at the Bama Belle site to obtain some basic hydrology information to assist in initial programming of the automatic samplers. With flow-weighted composite sampling, the samplers needed to be programmed to collect subsamples during the complete duration of the runoff event. In addition, a number of subsamples needed to be collected during the event to represent changing conditions. Finally, the automatic samplers had a limited volume for the collected composite sample and the analytical methods also had a required amount of needed sample for the laboratory analyses. Site hydrology conditions therefore needed to be characterized in order to develop the automatic sampler programs that were used during the sampling program.

Continuous flow monitoring using a calibrated ISCO area-velocity meter was used to monitor the discharge rates from the drainage area. In addition, an ISCO tipping bucket rain gage (ISCO 674) was installed at the monitoring location. This rain gage's main function was to initiate sampling when sufficient rainfall had fallen. Sample triggering based on flow was not very suitable at this site due to excessive humidity that often results in false positive starts when using water level indicators. The minimum stage rise needed to initiate sampling using the area-velocity sensor would result in false negative starts, resulting in missing small events. Therefore, previous research experiences had shown that direct measurements of rainfall from the rain gage was the most effective method for initiating automatic samplers in the area. The rain gage was not intended to result in accurate rainfall measurements, as the flow monitoring and sampling

site was adjacent to large trees. It was expected that these trees affected the accurate measurements of the rainfall. However, they did not affect the ability of the rain gage to trigger sampling. During the sampling program, it was intended to also locate a separate rain gage away from the trees in a more distant location in the monitored drainage area. However, that location was too distant to trigger the sampler.

Table 15 summarizes the rainfall and runoff values obtained during these nine events. There were a few missing data observations due to some missing rainfall records on the first event. Also, the second peak information for the March 9 event is only shown for peak intensities and flows, and therefore does not have an associated total event runoff volume or total rainfall (those are shown on the line for the initial peak).

Table 15. Rainfall and Runoff Data Collected at Monitoring Site

Sample Date	Runoff Depth (in)	Runoff Coefficient (Rv)	Runoff Duration (hr)	Average Runoff Rate (gal/hr)	Peak Rain Intensity (in/hr)	Peak Runoff Rate (ft³/sec)	Rational Equation C Coefficient
1/24/2010	1.35	1.01	7.9	4105	na	na	na
1/29/2010	0.9	1.23	11.5	1875	0.48	0.28	0.66
2/9/2010	0.48	1.14	5.4	2130	0.72	0.31	0.49
2/14/2010	0.22	1.29	4.6	1140	0.24	0.11	0.52
3/1/2010	0.65	0.93	6.9	2260	0.24	0.15	0.71
3/9/2010	1.9	0.98	21	2180	1.68	0.48	0.32
3/9 second peak	na	na	na	na	1.44	0.88	0.69
3/10/2010	1.09	1.14	11.9	2210	1.08	0.47	0.49
3/21/2010	0.48	0.86	9.1	1265	0.48	0.31	0.73

As indicated previously, the rainfall records were likely in error due to under-reporting the intensity values because of the adjacent trees. The rain volumes and rates were probably 15 to 25% lower than actual rainfall volumes and rates. However, these values were still used in

these analyses as this rain gage was used to trigger the sampler, and the sampler programming needed to be based on these values. The following figures show the relationships for some of these rainfall-runoff characteristics that were needed in the following discussion on programming the automatic samplers. The basic hydrology relationships shown in these figures were very consistent, but the rain depths and rates were likely under-reported, as noted above.

There were a number of sampling constraints that affect how the automatic samplers could be programmed. These included the number of subsamples required per event, the amount of sample volume needed for the analyses, and the range of runoff water volume expected over the wide range of likely events at the test location. In order to meet all of these requirements, three separate programming strategies of the automatic samplers were used, as described in the following discussion and as listed in Table 16. Both the influent and effluent samplers were triggered after the sampling site rain gage receives 0.03 inches of rain within a 30 minute period (corresponding to 3 tips of the tipping bucket rain gage). Smaller rains were not likely to result in site runoff.

Table 16. Automatic Sampler Programs for Different Expected Rain Event Condition

	Small Sized Events	Medium Sized Events	Large Sized Events
Rain Depth Range (in)	0.1-0.75	0.5-3.5	1.5-10.5
Rain Duration (hrs)	2 to 6	5 to 24	>15
Peak Rain Intensity (in/hr)	0.2 to 0.8	0.5 to 3.5	>1.5
Expected Runoff Volume for Event (gal)	2,450-18,400	12,300-85,800	36,800-260,000
Program Gallon/Subsample	200	1,000	3,000
Program each Subsample Volume (mL)	120	120	120
Expected # of Subsamples per Event	12-92	12-86	12-86
Expected 15L Capacity used for Event (%)	10-74	10-69	10-69
Expected Sample Volume per Event (L)	1.5 to 11	1.5 to 10	1.5 to 10

TARP requires a minimum of 5 subsamples per event, while TAPE requires a minimum of 10 subsamples per event. The sampler programs noted in Table 16 are designed to collect from 12 to 92 subsamples per event. It is likely that some of the smallest events in each category may produce less runoff than expected, periodically resulting in somewhat less than 12 subsamples. Had fewer than 10 subsamples occurred frequently, the programs were modified. There were few obvious small storms predicted from the local weather forecast during the monitoring period. The majority of the samples were collected using the “Medium Size” program, three events were monitored using the “Small Size” program, but no events used the “Large Size” sampling program.

The required minimum sample volume needed for the basic list of analyses was about 1 L. In order to collect sufficient sample volumes with the required number of subsamples, and given the 15 L volume of the composite sample container, the automatic samplers were programmed according to the expected rain conditions. As indicated in Table 16, there were three programs, which were for small sized events (0.1 to 0.75 inches of rain), medium sized events (0.5 to 3.5 inches of rain), and for large sized events (1.5 to 10.5 inches of rain).

The small sized events were expected to generate about 2,500 to 18,400 gallons of runoff from the site. Each subsample was set for 120 mL of water, and each subsample was collected for each 200 gallons of stormwater runoff. A minimum of 12 subsamples were expected to be collected, resulting in about 1.5 L of sample for analyses. The medium and large sized events were programmed to collect each subsample after every 1,000 and 3,000 gallons of runoff, respectively. This was the only change in the sampler programming, so human error was expected to be minimal. As noted, there was significant overlap between the rain ranges for each category. In fact, the upper end was actually larger by about 50% as the sampler container was 15 L and these programs were shown to have upper limits of only about 10 and 11 L. These overlaps and safety margins also were also intended to decrease problems associated with actual rain conditions not being within the expected range.

Before the samplers were programmed, rain forecasts from several reliable government and news sources were consulted. In most cases, the medium sized event program was used, with the two extreme programs used only under when unusual conditions were expected. This medium sized program was associated with more than 80% of the annual runoff volume expected from this site, with the two others only associated with about 10% of the annual runoff volume each.

The average runoff rates monitored for the site ranged from about 1,100 to 2,200 gallons per hour for the small sized rains. The small event program collected a sample every 200 gallons, so the sub-sampling rate could be about 6 to 11 per hour, or a subsample every 5 to 10 minutes, on the average. Peak flows were expected to be about 4 times these average runoff rates, based on the pre-sampling hydrology monitoring, so peak sub-sampling rates could be about one subsample collected every 1.5 to 3 minutes. The ISCO samplers required about 1.5 minutes to collect small subsamples, based on the required time for the initial back flush of the sample line, sample collection, and the final back flushing of the sample line (G. A. Burton & R. Pitt, 2001).

Therefore, there was only a slight chance that a subsample collected, even at the time of the peak flow during the small events, could cause the sampler to operate continuously. This would not damage the sampler or contaminate the sample, but could result in somewhat less sample volume being collected at this time. In all likelihood, the subsample pulse would not occur simultaneously with the peak flow rate. The sampler records when each subsample is obtained, so this condition would be identified if it occurred. This problem would not occur during the medium and large event programs as the subsample pulses occur at greater intervals: at 1,000 and 3,000 gallons of runoff. The average runoff rates during these larger events were expected to range from about 1,900 to possibly 4,000 gallons per hour. This would result in subsamples being collected, on the average, about every 15 minutes, or longer, or about every 3 minutes, or longer, during instantaneous peak flows. Again, these subsampling rates were not expected to cause problems with sampling rate requirements of the samplers.

For longer duration, or larger, storms that may exceed the capacity of the composite container, additional empty 15 L composite containers replace the filled composite containers. The samplers were automatically halted if the rainfall was less than 0.03 inches in a 30 minute

period. The samplers therefore could be stopped and started several times during a storm.

Samplers started to collect samples again once the rainfall reached more than 0.03 inches where they had previously stopped. Both samplers for the influent and effluent operated together. They both started and stopped at the same time. The first samples were collected after 0.03 inches of rainfall occurs within 30 minutes.

Once the samplers stopped at the end of the runoff event, the sampling reported its status which was recorded by the data logger in the flow meters. These data were downloaded, along with the rain and flow data, and the sondes data. The composite sample containers were retrieved and delivered to the laboratory where the samples were processed and analyses commenced. The samplers were then reset to automatically start at the next storm. Before an expected rain, the weather conditions were checked and the samplers reprogrammed, if needed, and the sondes were placed in their runoff monitoring configuration. The flow meters were not reset, as they continuously took readings between events in case of any dry-weather flows, and to capture rainfall and runoff that could have occurred for unmonitored events.

3.12.14 *Estimated Total Number of Samples*

Based on the proposed sampling protocols, at least 12 event pairs were analyzed for the primary pollutant constituents. This sample set included at least one inlet and one outlet sample. In order to test the protocols, many more sample sets were collected over a wider range of conditions. All possible runoff events were monitored during the sampling period, resulting in a total of 20 pairs of events sampled during the monitoring period of July 2010 to April 2011.

Sediment samples were taken at the end of the monitoring program from the sump of the Up-Flo[®] Filter in order to quantify the overall removal capacity of the device. The sump material

was collected and analyzed on May 10, 2011 to determine the total volume (depth of the material) and particle size distribution, as shown in Chapter 5.2.9.

3.12.15 *Sample Handling*

Water samples were collected using the automatic samplers. A peristaltic pump on the sampler pumps water from the sampling location through Teflon™ lined sample tubing to the pump head where the water passed through and deposited into the 15 L composite sample container on a flow-weighted basis, as described above. The sample containers were capped and removed from the samplers after the event. All the samples were transported to the laboratory in iced coolers at the Department of Civil, Construction, and Environmental Engineering at the University of Alabama, where they were split into multiple bottles for analysis using a Dekaport/USGS cone splitter (Rickly Hydrological Company). Table 17 shows the handling time for the constituents.

Table 17. Required Volume and Storage Time for Physical and Chemical Analysis (Standard Method, 2005)

Pollutant Constituent	Required Volume (mL)	Preservation	Storage Time
Total Solids	100	cool 4°C	n/a
Suspended Solids	100	cool 4°C	n/a
Metals	45	cool 4°C	6 months after digestion
COD	2	cool 4°C	28 day
Phosphorus	5	cool 4°C	28 day
Nitrate	40	cool 4°C	48 hr
Ammonia	2	cool 4°C	28 day
E-Coli, Total Caliform, and Enterococci	20 mL for 1 in 10 dilution	cool 4°C	6-10 hrs

3.12.16 *Sampler Maintenance*

The sampler was checked to ensure that it is functioning properly after each event. Batteries were changed after each event. Blank samples were collected twice during the monitoring period in order to verify that the sampler has not contaminated the collected samples.

3.12.17 *Field Sheet*

A field sheet was filled out during each site visit for documentation of the field monitoring activities. All activities during the site visit were recorded. Field sheets were filled out each time that samples are collected after an event. Table 18 shows the example of the field sheet used in this project.

3.12.18 *Automated Data Recording*

Continuous monitoring data was recorded using the internal memory of the devices and then backed up using the external storage module. Data from the sampling period was transferred after the event during dry conditions to the laptop computer. Data then were analyzed and reported.

3.12.19 *Precipitation Measurements*

The rainfall intensity and depth were collected using a standard tipping bucket rain gauge (ISCO 674 Rain Gauge) as well as the small totalizing rain gauge for the verification of accuracy. The total rain depths were checked after each event by comparing the recorded values to the totalizing rain gauge located at the side of the tipping bucket.

3.12.20 *Additional Monitoring*

At the end of the monitoring period, the Up-Flo[®] Filter sump sample was collected using a dipper grab sampler and the amount of material retained in the sump was measured, as described in Chapter 5.2.9. The material was removed from the sump, dried, and weighed and the particle size analysis was conducted.

3.12.21 *Regulatory Criteria*

The City of Tuscaloosa has a Phase 2 stormwater discharge permit that includes the test site. There were no specific monitoring or treatment requirements in this permit. However, the City was very interested in reducing their stormwater pollutant discharges and was cooperating with these studies by providing installation of the Up-Flo[®] Filter and other important support activities. These other activities had included providing public works crews and equipment to help with the controlled tests and periodic cleanout operations of the filter sump. Most

importantly, they were providing continued access to the site and general maintenance with the sampling installation. The City had also used the preliminary results of the tests to modify different aspects of their stormwater program, such as by encouraging the use of these devices in critical local installations.

3.13 QA/QC Methods

This quality assurance project plan (QAPP) specified the procedures that were followed to ensure the validity of test data and their use as the basis for equipment performance verification. This QAPP addressed the activities of Department of Civil, Construction, and Environmental Engineering at the University of Alabama, including sample collection, sample analysis, and data recording and analysis.

3.13.1 *Data Quality Indicators*

Several Data Quality Indicators (DQIs) have been identified as key factors in assessing the quality of data and in supporting the verification process. These indicators include:

- Precision
- Representativeness
- Comparability
- Completeness

Each DQI is described below and the goals for each DQI are specified. Performance measurements were verified in Chapter 7 using statistical analysis of the data for the quantitative DQI's of precision. If any QA objective were not met during the tests, an investigation of the causes was initiated. Corrective actions were taken as needed to resolve any difficulties. Data

failing to meet any of the QA objectives were flagged, and a discussion of the issues impacting the QA objectives are presented in Chapter 7.

3.13.2 Precision

Precision refers to the degree of mutual agreement among individual measurements and provides an estimate of random error. Analytical precision is a measurement of how far an individual measurement may deviate from a mean of replicated measurements. Precision is determined from analysis of field and laboratory duplicates and spiked duplicates, as shown in Chapter 7. The standard deviation (SD), relative standard deviation (RSD), relative percent difference (RPD), or range (absolute difference) methods were used to quantify precision. The relative percent difference is calculated by the following formula:

$$\%RPD = \left(\frac{|x_1 - x_2|}{x} \right) \times 100\%$$

where:

- x_1 = Concentration of compound in sample
- x_2 = Concentration of compound in duplicate
- x = Mean value of x_1 and x_2

Field duplicates were collected for both influent and effluent samples. The field duplicates were collected two times during the test period. Duplicates were analyzed on a frequency of one duplicate for every ten samples analyzed. The laboratory conducted duplicate samples as part of the laboratory QA program on the September 26, 2010 and February 25, 2011 samples. The results are shown in Chapter 7.

3.13.3 *Comparability*

Comparability was achieved by using consistent and standardized sampling and analytical methods. All analyses were performed using EPA or other published methods as listed previously.

3.13.4 *Representativeness*

Representativeness is the degree to which data accurately and precisely represent a characteristic population, parameter at a sampling point, a process condition, or an environmental condition. The test plan design calls for flow-weighted composite samples of influent and effluent to be collected and then analyzed. The sampling locations for the samples were designed for easy access and were directly attached to the pipes that carry the raw stormwater, or treated stormwater. This design helped ensure that a representative sample of the flow was obtained in each composite sample bottle. The sample handling procedure included a thorough mixing of the composite container prior to pouring the complete samples into the individual containers via means of a cone splitter. The laboratory followed set procedures (in accordance with good laboratory practice) for thorough mixing of any samples prior to subsampling in order to ensure that samples are homogenous and representative of the whole sample, as described by Clark and Pitt (2008) and Clark and Siu (2008).

The Up-Flo[®] Filter was operated in a manner consistent with the supplied O&M manual, so that the operating conditions were representative of a normal installation and operation for this equipment.

Representativeness was monitored through QA/QC audits (both field and laboratory), including review of the laboratory procedures for sample handling and storage, review and observation of the sample collection, and review of the operating logs maintained at the test site.

HydroInternational engineers and the research director conducted periodic site visits to audit the testing procedures.

Obtaining representative samples for stormwater is fundamentally a difficult challenge, and attention to details during sample collection, handling and analysis were required. Proper system design, sampler selection, flow meter selection, location of inlet tube, mixing sample container handling, and splitting helped maximize the representativeness of stormwater samples.

3.13.5 *Completeness*

Completeness is a measure of the number of valid samples and measurements that are obtained during a test period. Completeness was measured by tracking the number of valid data results against the specified requirements in the test plan.

Completeness were calculated by the following equation:

$$\text{Completeness} = (V / T) \times 100\%$$

where:

V = number of valid measurements

T = total number of measurements planned in the test

The goal for this data quality objective was to achieve a minimum of 75% completeness for samples scheduled in the test plan. This accomplishment is described in Chapter 7.

3.13.6 *Field Quality Assurance*

Sampling procedures were defined previously. The sampling schedule was developed to provide samples that were representative of the seasonal and meteorological conditions of the site.

Efforts were made to maintain high sampling efficiency by providing sampling personnel with written procedures and training to assure the samples are properly collected, handled, and transported to the lab.

Sampling and flow measurement equipment were calibrated and maintained in accordance to manufacturer's recommendations.

All sampling equipment was decontaminated prior to the sampling test period except the sampler bottles and cone splitter were decontaminated before each event. Decontamination procedures consisted of scrubbing the composite bottles with Liqui-Nox™, or other appropriate cleaner, and rinsing with deionized water prior to use. Bottles were then be rinsed with five percent hydrochloric acid solution followed by three rinses of deionized water. Thr same procedure was used to clean the sample splitter between samples except that they were not air dried. Following sample collection, clean composite bottles were placed in the sampler, and the used bottles were brought back to the laboratory for decontamination.

The sample bottles were obtained from the sampler, placed in a cooler with ice, and brought to the laboratory for analysis. The Department of Civil, Construction, and Environmental Engineering at the University of Alabama split the samples using a USGS/Dekaport cone splitter into appropriate sample containers for analyses. The samples were maintained in the custody of the sample collectors, delivered directly to the laboratory and

relinquished to the laboratory sample custodian(s). Custody was maintained according to the EPA or other published sample handling procedures as described in Tables 14 and 17.

To establish the necessary documentation to trace sample possession from the time of collection, field forms and lab forms were filled out and accompanied each sample. Field forms recorded the date and time of sample collection, number of samples, and personnel conducting the sample collection. Samples were not left unattended unless placed in a secure and sealed container with the field forms inside the container.

3.13.7 *Equipment Maintenance and Calibration*

The samplers, flow meters, and rain gauge were calibrated, inspected and cleaned according to the manufacturer's specifications. The flow meter was calibrated during the controlled test. Samplers were inspected after each event. The rain gauge was inspected and cleaned after each event.

3.13.8 *Laboratory Quality Assurance*

Comparability of the data was achieved by using standardized analytical techniques and reporting the data in professionally accepted units for concentrations, flow, and loadings.

All analyses apart from metal analysis were performed at the Department of Civil, Construction, and Environmental Engineering at the University of Alabama. Metal analyses were conducted by Stillbrook, Environmental Testing Laboratory, Inc., of Birmingham, AL

Analytical methodologies and detection limits for each constituent analyzed were summarized previously in Table 14.

3.13.9 *Quality Control Procedures*

Sources of variability and bias introduced by sample collection and stream flow measurement could affect the interpretation of concentration data and calculated constituent loads. The following were quality-assurance and quality control (QA/QC) procedures that were applied to the sampling of water chemistry and to the measurement of stream flow and precipitation. Standard QA/QC methods and definitions for sample collection are published in Burton and Pitt (2001).

3.13.9.1 Field Blanks

Any sampling or analytical source of contamination was tested and minimized using field and laboratory blank samples. A total of two field blanks were collected on site to evaluate contamination in the entire sampling process, which includes all equipment (automatic sampler, sample-collection bottles, and splitters), filtering procedures, and analytical procedures. “Milli-Q” reagent water was pumped through the automatic sampler and processed and analyzed in the same manner as event samples were processed. The first field blank was collected near the beginning of the sampling period. This allowed the results to be available at the earliest possible time in the monitoring schedule to any needed adjustments. The next field blank was taken at the midpoint of the sampling schedule.

3.13.9.2 Replicates

During the monitoring period, two replicate samples from the inlet and outlet monitoring were collected to evaluate precision in the sampling process and analysis. The samples were taken from the composite sample collected at each site for each event and split into two separate samples. They were delivered to the laboratory, and analyzed in the same manner as the regular

samples. Variability in results from a series of these replicates was given an indication of precision in the process. The first replicate was collected on September 26, 2010. This was intended to allow results at the earliest possible time in the monitoring schedule to make adjustments if necessary. The next replicate was taken on February 25, 2011, at the midpoint of the sampling schedule.

3.13.9.3 Precipitation Measurement

The tipping bucket rain gauge was used to trigger the automatic sampler and was not intended to be an accurate indication of the actual rainfall conditions, due to the interferences of trees near the monitoring location. The performance of the Up-Flo[®] Filter was a function of stormwater discharge, and those measurements was calibrated during the controlled test. The rain gage was indicated the basic rainfall information, but the measured rain intensities appear to be about 15 to 25% too low. The rain gauge was checked for debris and cleaned after each event.

3.13.9.4 Flow Measurement

For this project, ISCO 2150 area-velocity meters were used to measure velocity and water level in the storm sewer at the two locations (inlet and outlet). These were calibrated on site using pumped water from the Black Warrior River during the controlled test.

3.13.9.5 Sample Delivery to Laboratory

Samples were transported to the laboratory as soon as the rain had ended. The monitoring locations were within 2 miles of the main processing laboratory on the UA campus, so delivery times were very short.

Date and time of sample collection and test setup and arrival temperature were recorded. Appropriate field forms, logs, and sheets were completed on site at the time of sample collection. All entries were written in waterproof ink, signed and dated.

3.13.9.6 General QA/QC Documentation and Reviews

All QA/QC results were documented to represent results. QA samples data were reviewed after the analysis and there were no significant problems were identified.

3.13.9.7 Quality Assurance Reports

Quality Assurance Reports were included as part of the verification report. The reports consisted of QA/QC reports from the laboratories, maintenance records, and written documentation maintained throughout the testing period.

The results included field blank results, laboratory blanks, duplicate analysis result, analytical methods, sample collection procedure, and completeness. All works were performed within the established QA/QC protocol as outlined in the laboratory QA/QC Plan. All analytical methods were followed either EPA approved methods or from *Standard Methods, 20th edition*.

3.13.9.8 Quality Assurance Assessments

Three field audits were conducted during the test period on March 2009, April 2010, and February 2011. The audits included observing the sample collection procedures, operation of the unit, and condition of the test site. One lab audit was performed on February 2011 to observe sample receipt, handling, storage, and analytical methods.

CHAPTER 4

4: EVALUATION OF RESULTS AND VERIFICATION OF PROTOCOLS

4.1 Introduction

Analytical results from different scales and test protocols for the upflow filtration device were available from this dissertation research and from early studies. In this chapter, previous bench-scale and pilot-scale test data were compared to the results of the full-scale tests in order to identify scaling differences and uncertainties associated with different testing environments.

The first set of data was collected during the EPA's SBIR I (Small Business Innovative Research) project (US Infrastructure, 2003). Tests were conducted in the lab using a test sediment of clay, as well as in the field using pilot-scale filters and actual pre-treated stormwater runoff from a stormwater detention pond (to test the filter processes after preliminary sedimentation treatment).

The second set of data was collected during pilot-scale tests of the upflow filtration device under actual storm conditions during the SBIR II project, reported by Khambhammettu (2006). Results from the full-scale field tests conducted during this PhD research efforts during actual storm conditions were used for comparison to these earlier data. The methodology of the controlled tests conducted during the SBIR II project was the same as was conducted during the full-scale tests, as described in Section 3.11.4.

Khambhammettu conducted the controlled tests using three different flow rates and collected 84 samples, including the blank samples for each experiment. The “high” flow rate during these controlled tests was approximately 27 gpm (corresponding to a rate of 150 gpm for a full-scale upflow filter), which was the flow rate at the largest height of driving head possible before bypassing occurred. The “medium” flow was about 15 gpm (75 gpm for full-scale) and the “low” flow was about 5 gpm (25 gpm for full-scale). The same CPZ Mix™ media (a mixture of granular activated carbon, peat moss, and manganese-coated zeolite) was used during these, and most subsequent, tests.

The third data set was from the full-scale single-module tests conducted as part of the EPA’s ETV (Environmental Technology Verification) by the Penn State Harrisburg’s Environmental Engineering Wastewater Laboratory (Penn State Harrisburg, 2007). These tests included four different test phases under different flow conditions.

Additional background data for the sump process was available from tests conducted during the EPA catch basin research conducted by Pitt and Field (1998). Three storm drain inlet devices were examined in Stafford Township, New Jersey. A conventional catch basin with sump, and two other inlet devices with filters, were tested for performance during actual storm conditions. The catch basin was rebuilt based on the recommended Lager and Smith (1977) dimensions. These data were used as a reference for the potential treatability for the catch basin with sump, similar to the processes occurring in the sedimentation chamber of the upflow filter.

Table 19 compares the recent full-scale upflow filter performance and the SBIR I (pilot-scale, using pre-treated stormwater) testing data (US Infrastructure, 2003) for several common parameters. SBIR I research had two phases including the laboratory based test using the simulated solids and the pollutants removal test using actual stormwater runoff from the Star

Lake wet detention pond in Hoover, Alabama. This pond was fed by stormwater runoff primarily from a medium-density residential area. The pilot-scale filtration columns were constructed using large (55 gallon) polyethylene tanks. The pilot-scale filter data is shown in the table below. The pilot-scale SBIR I filter tests had significantly lower sediment concentrations compared with the full-scale test, as the test water used was previously treated by the wet pond sedimentation processes in order to test the column behavior when receiving mostly “dissolved” pollutant forms .

Table 19. Current and SBIR I Project Under Actual Storm Event Data Comparison (average concentrations)

	Bama Belle (full-scale*)			SBIR I (pilot-scale filter) US Infrastructure (2003)		
	Influent	Effluent	Reduction (%)	Influent	Effluent	Reduction (%)
TSS (mg/L)	62.3	20.5	66.0	6	5	5.7
TDS (mg/L)	112.8	66.9	34.8	NA	NA	NA
SSC (mg/L)	75.8	21.7	68.1	NA	NA	NA
Turbidity (NTU)	18.2	7.4	50.3	12	10	21.4
Conductivity (µS/cm)	124.0	85.9	23.2	NA	NA	NA
pH	6.85	6.96	-1.77	7.63	7.78	-2.0
Total COD (mg/L)	42.1	24.3	43.4	18.5	12.9	30.4
Filtered COD (mg/L)	25.2	16.3	43.1	NA	NA	NA
Total Pb (µg/L)	BDL	BDL	NA	11	3	72.7
Nitrate (mg/L)	0.9	0.6	27.8	1.0	0.8	23.8
Ammonia (mg/L)	0.09	0.04	52.4	0.063	0.052	17.0
Phosphorus	1.3	1.0	21.6	0.17	0.05	68.7
E-Coli (#/100 mL)	6620	3091	54.3	243	153	37.0
Total Coli (#/100 mL)	7368	4825	42.1	2400	2200	8.3
Zinc (µg/L)	0.09	BDL	>77.8	BDL	BDL	NA
Filtered zinc (µg/L)	0.075	0.03	60	BDL	BDL	NA
Total Cd (µg/L)	BDL	BDL	NA	1.90	1.89	0.8

* the additional benefits of the sump are not shown on this table

** the filtered lead, total and filtered copper, and filtered cadmium were all undetected in all of the samples for all of these tests, and are therefore not shown.

Table 20 to 22 compare the removal capability of the CPZ Mix™ Media under “Low”, “Medium”, and “High” controlled flow conditions for the full-scale and the pilot-scale upflow filter tests. The pilot-scale tests of the upflow filter were reported by Khambhammettu (2006) as part of the Phase II project of the US EPA’s Small Business Innovative Research (SBIR) program. Controlled tests were conducted using the similar test sediments as the full-scale test. The “High” flow rate was approximately 27 gpm (150 gpm for full-scale) which is the flow rate at the largest height of driving head possible before bypassing. The “Medium” flow was measured about 15 gpm (75 gpm for full-scale) and the “Low” flow was about 5 gpm (25 gpm for full-scale). Although the influent and effluent sediment concentrations were similar for both sets of controlled tests, the reduction rates were slightly higher for the pilot-scale tests compared with the full-scale upflow filter tests, especially for the lower flow, low concentration tests.

Table 20. Full and SBIR II Controlled Test Comparison in “Low” Flow Rate for CPZ Mix™ Media (average concentrations)

Target TS (mg/L)	Khambhammettu (Pilot-Scale) (2006)			Full-Scale Controlled Test Result		
	Influent	Effluent	Reduction (%)	Influent	Effluent	Reduction (%)
50	76	11	86	41	24	41
100	97	6	94	83	20	76
250	242	10	96	200	25	88
500	492	31	94	390	55	86

Table 21. Full and SBIR II Controlled Test Comparison in “Medium” Flow Rate for CPZ Mix™

Media (average concentrations)

Target TS (mg/L)	Khambhammettu (2006)			Full-Scale Controlled Test Result		
	Influent	Effluent	Reduction (%)	Influent	Effluent	Reduction (%)
50	59	19	68	45	25	44
100	99	22	78	90	32	64
250	252	37	85	224	63	71
500	485	52	89	423	105	75

Table 22. Full and SBIR II Controlled Test Comparison in “High” Flow Rate for CPZ Mix™

Media (average concentrations)

Target TS (mg/L)	Khambhammettu (2006)			Full-Scale Controlled Test Result		
	Influent	Effluent	Reduction (%)	Influent	Effluent	Reduction (%)
50	54	11	80	61	18	71
100	92	22	76	124	51	58
250	250	46	82	311	108	65
500	490	79	84	584	207	65

Table 23 indicates the performance comparison for the full-scale and pilot-scale test upflow filter tests during actual storm events for several common parameters. Pilot-scale tests (SBIR II) were conducted using a prototype upflow filter located in a retrofitted catch basin located in the parking lot of the Tuscaloosa City Hall, Alabama. The catch basin received runoff from a 0.9-acre drainage area consisting of parking, roofs, and adjacent storage areas. The prototype device was sized at approximately ¼ of the optimal size for the area with a nominal 25 gpm peak treatment flow rate (excess flow would bypass the unit). The filtration rate required for treating 90% of the annual flows at the test site was estimated to be about 100 gpm, while the average runoff flow for the observed rain events during these tests was 44 gpm. The drainage

areas for the full-scale and the pilot-scale locations were similar, however; each site had somewhat different land uses generating different influent pollutants concentrations.

Table 23. Full and SBIR II Comparison under Actual Storm Event (average concentrations)

	Bama Belle Data* (up to April, 2011)			Khambhammettu (2006)		
	Influent	Effluent	Reduction (%)	Influent	Effluent	Reduction (%)
TSS (mg/L)	62.3	20.5	66.0	137	90	34.3
TDS (mg/L)	112.8	66.9	34.8	NA	NA	NA
SSC (mg/L)	75.8	21.7	68.1	64	19	70.3
Turbidity (NTU)	18.2	7.4	50.3	43	15	65.1
Conductivity (μ S/cm)	124.0	85.9	23.2	NA	NA	NA
pH	6.85	6.96	-1.77	NA	NA	NA
Unfiltered COD (mg/L)	42.1	24.3	43.4	111	81	27.0
Filtered COD (mg/L)	25.2	16.3	43.1	NA	NA	NA
Unfiltered Pb (μ g/L)	BDL	BDL	NA	15.5	5.5	64.5
Filtered Pb (μ g/L)	BDL	BDL	NA	11.3	2.8	75.2
Unfiltered Cu (μ g/L)	BDL	BDL	NA	13	8.7	33.1
Filtered Cu (μ g/L)	BDL	BDL	NA	5.7	5.7	0
Nitrate (mg/L)	0.9	0.6	27.8	0.7	0.7	0
Ammonia (mg/L)	0.09	0.04	52.4	0.44	0.24	45.5
Phosphorus	1.3	1.0	21.6	0.94	0.77	18.1
E-Coli	6620	3091	54.3	4750	3290	30.7
Total Coliforms	7368	4825	42.1	12400	6560	47.1
Zinc (μ g/L)	0.09	BDL	>77.8	169	130	23.1
dissolved zinc (μ g/L)	0.075	0.03	60	103	116	-12.6
total Cd (μ g/L)	BDL	BDL	NA	1.7	2.6	-52.9
dissolved Cd (μ g/L)	BDL	BDL	NA	7.6	2.2	71.1

* these data do not include the coarser sump material

Tables 24 and 25 compare the full-scale (six module unit) tests and the single module full scale unit, under the controlled conditions. The single module controlled unit tests were conducted by the Penn State Harrisburg Environmental Engineering Wastewater Laboratory (2007) as part of the EPA's ETV program. Four test phases were conducted with different conditions including 1) performance under intermittent flow conditions, 2) long-term steady flow

to determine capacity of the unit, 3) performance under varied hydraulic and concentration conditions, and 4) high hydraulic conditions.

Table 24 compares the phase 2 of the PSH test and the full-scale “Low” flow rate (approximately 25 gpm) test. During the phase 2 test, the unit was operated under continuous at approximately 16 gpm. The treatment flow rate was therefore about 20 to 30 gal/min/ft², and the “Low” flow conditions of the full-scale test were selected as a comparison.

Table 24. Six and Single Module Controlled Test Comparison in “Low” Flow Rate (average concentrations)

Target TSS (mg/L)	Penn State Harrisburg (2007)			Full-Scale Controlled Test Result		
	Influent	Effluent	Reduction (%)	Influent	Effluent	Reduction (%)
100				83	20	76
250	132	34	74	200	25	88

Table 25 compares the phase 4 data of the PSH tests with the full-scale “High” flow rate (approximately 150 gpm) test. The phase 4 PSH test was conducted under very high flows, at approximately 32 gpm (greater than the design flow of 20 gpm), in order to determine the performance of the unit under high hydraulic conditions. Reduction rate of both testing were similar. As shown in both Tables 25 and 26, the test results were similar.

Table 25. Six and Single Module Test Comparison in “High” Flow Rate for CPZ Media (average concentrations)

Target TS (mg/L)	Penn State Harrisburg (2007)			Full-Scale Controlled Test Result		
	Influent	Effluent	Reduction (%)	Influent	Effluent	Reduction (%)
100				90	32	64
250	121	46	62	224	63	71

Table 26 represents the data collected during the field evaluations of catch basin sumps conducted by Pitt and Field (1998). They evaluated three storm drain inlet devices in Stafford Township, New Jersey, including the conventional catch basin with sump, and two other inlet devices with filters under actual storm conditions. The data shown on Table 26 is only for the sedimentation processes in the sump as an indication of the effectiveness of this unit treatment process alone.

Table 26. Observations of Catchbasin Sump Performance (average concentrations)

	Pitt and Field (1998)		
	Influent	Effluent	Reduction (%)
TS (mg/L)	122	95	22.1
DS (mg/L)	48	44	8.3
SS (mg/L)	75	51	32.0
Turbidity (NTU)	59.9	37.1	38.1
Conductivity ($\mu\text{S}/\text{cm}$)	56.3	62.6	-11.2
pH	6.96	6.95	0.1
Unfiltered COD (mg/L)	22.8	20.3	11.0
Filtered COD (mg/L)	10	14.9	-49.0
Unfiltered Pb ($\mu\text{g}/\text{L}$)	5.28	3.36	36.4
Filtered Pb ($\mu\text{g}/\text{L}$)	1.37	1.25	8.8
Unfiltered Cu ($\mu\text{g}/\text{L}$)	30.63	25.58	16.5
Filtered Cu ($\mu\text{g}/\text{L}$)	15.5	16.5	-6.5
Nitrate (mg/L)	1.067	1.247	-16.9
Ammonia (mg/L)	0.219	0.248	-13.2

A number of statistical approaches were used to evaluate and compare the performance data collected during these different projects. Several graphical analyses of the data were initially conducted, followed by regression analyses, with ANOVA and residual analyses, to create simple performance models.

Protocols were also evaluated in a later chapter for possible modification and for guidance in merging protocols. The results of these different evaluations were compared to indicate how transferable the evaluation methods could be across the protocol methods, considering scale and effort for each.

4.2 Laboratory Technology Performance under Different Flows and Sediment Characteristics using UpFlow Filter

Performance under a wide range of flow conditions for highly variable sediment and pollutant characteristic was the primary measure for the usefulness of a treatment device. Four different evaluations of the upflow filter have conducted in the laboratory and field using different test sediments and under different flow rates, as briefly described below.

The SBIR I project used clays and fine sands less than 200 μm in nominal diameter having 500 mg/L to 1,000 mg/L concentrations. Unlike other tests, SBIR I project used glass graduated burettes (inner diameter of 50.8 mm), giving a cross-sectional area for filtration of 20 cm^2 (0.022 ft^2) and with 3.4 to 5.5 gpm flow rates (160 to 260 gpm/ft^2) (US Infrastructure, 2003).

The SBIR II projects used different combinations of ground silica and sieved sand over a wider range of particles sizes, from about 0.45 to 2,000 μm . Three different flow rates were selected for these tests: “high” flow rate (approximately 27 gpm), “medium” flow rate (approximately 15 gpm), and “low” flow rate (approximately 5 gpm); with each flow tested using four different SSC concentrations of 50, 100, 250, and 500 mg/L (Khambhammettu, 2006). The Penn State Harrisburg Environmental Engineering Wastewater Laboratory conducted controlled full-scale tests of the upflow filter using a single module. Their challenge mixture included ground silica solids, particulate phosphorus (ground slow-release fertilizer), and oil and

grease additives. Four different test phases were conducted with design flow rates of 10 to 32 gpm and influent SSC concentrations ranged between 121 and 237 mg/L (Penn State Harrisburg, 2007). The full scale (6 module type) controlled tests were conducted using the ground silica and sieved sand mixture with four different concentrations of 50, 100, 250, and 500 mg/L, same as the SBIR II project. Three different design flow rates used were 25, 75, and 150 gpm. The following table (Table 27) summarizes the laboratory/controlled test results of four different analyses.

Table 27. Laboratory/Controlled Test Summary

	SBIR I	SBIR II	Pen State Harrisburg	Full-Scale Test BamaBelle
Data Type	Laboratory	Field (controlled)	Laboratory	Field (controlled)
Design Flow Rate (gpm)	3.4~5.5	5~27	10~32	25~150
Flow Rate for Module (gpm/ft ²)	160~260	3~18	7~21	3~17
Number of Modules	1	1	1	6
Total Module Surface Area (ft ²)	0.022	1.5	1.5	9.0
Influent SSC (mg/L)	250~560	54~492	49~391	41~584
Effluent SSC (mg/L)	80~220	6~79	3.6~49	18~210
SSC Average Reduction (%)	43~77	68~96	0~99	41~88
Sediment Type	Clay + fine sand	ground silica + sieved sands	ground fertilizer (phosphorus source) + sieved sands + oil and grease	ground silica + sieved sands
Particle Sizes (µm)	<200	0.45~2000	0.6~1000	0.45~2000

The SBIR I tests were conducted to develop and demonstrate the effectiveness of the upflow filtration method for the treatment of stormwater runoff, mostly as a proof of concept. It examined the down flow filtration clogging model with upflow filtration. Two phases of these tests were conducted using simulated and actual stormwater. The model removed about 43 to 77 % of the SSC in the laboratory setup using the simulated stormwater.

The SBIR II tests (pilot-scale field study) was conducted by Khambhammettu (2006) as part of the Phase II project of the US EPA's Small Business Innovative Research (SBIR) program. Testing was conducted using both controlled flow tests and during actual rain events. In the controlled verification process, the device removed approximately 68 to 96 % of the SSC.

The Penn State Harrisburg Environmental Engineering Wastewater Laboratory (2007) evaluation study was conducted using controlled laboratory tests of a single module in a full-size unit as part of the EPA's ETV program. Four different test phases were conducted as described above and resulted in SSC reductions ranging from almost zero to complete removals, depending on the test conditions.

The full-scale tests were conducted in the field using both controlled and actual storm events. The SBIR II and the full-scale tests used similar sediment material and mixtures, filter media, and sediment concentrations. The SBIR II device was approximately one-fourth of the size of the full-scale, and was under-sized for the test location. The full-scale device at the Bama Belle location removed from 41 to 88 % of SSC, depending on the influent SSC concentration and the age of the filter bags.

4.2.1 *Statistical Variation in Influent vs. Effluent Concentrations for SSC*

Several statistical tests of multiple pairwise comparisons of groups are available. The most common approaches include: Least Significant Difference (LSD), Bonferroni Multiple Comparison, and the Tukey-Kramer test. One of the primary requirements for these methods is that the data are normally distributed. When data are not normally distributed, there are two commonly used approaches. The first is to transform the data using logarithmic or square root transformations in an attempt to obtain a transformed normal distribution. One potential problem with this method is that the units of the transformed data may be difficult to interpret due to the logarithmic manipulation. The second method for dealing with non-normally distributed data is to use a non-parametric analysis having fewer data distribution requirements. The Kruskal-Wallis test is usually represented as the nonparametric version of the parametric ANOVA test. This test is used to determine if at least one group is significantly different from the other groups being compared. This test compares the population medians of the groups, instead of the population means used by ANOVA. The Kruskal-Wallis method tests the hypothesis that all population medians are equal (Gibbons, 1997). The multiple comparison tests shown below were conducted using a MINITAB macro in a nonparametric setting (Orlich, 2010). The following figures describe the significance difference for the influent and effluent SSC concentrations for the four sets of experiments. Detailed calculation results are attached in the Appendix B.

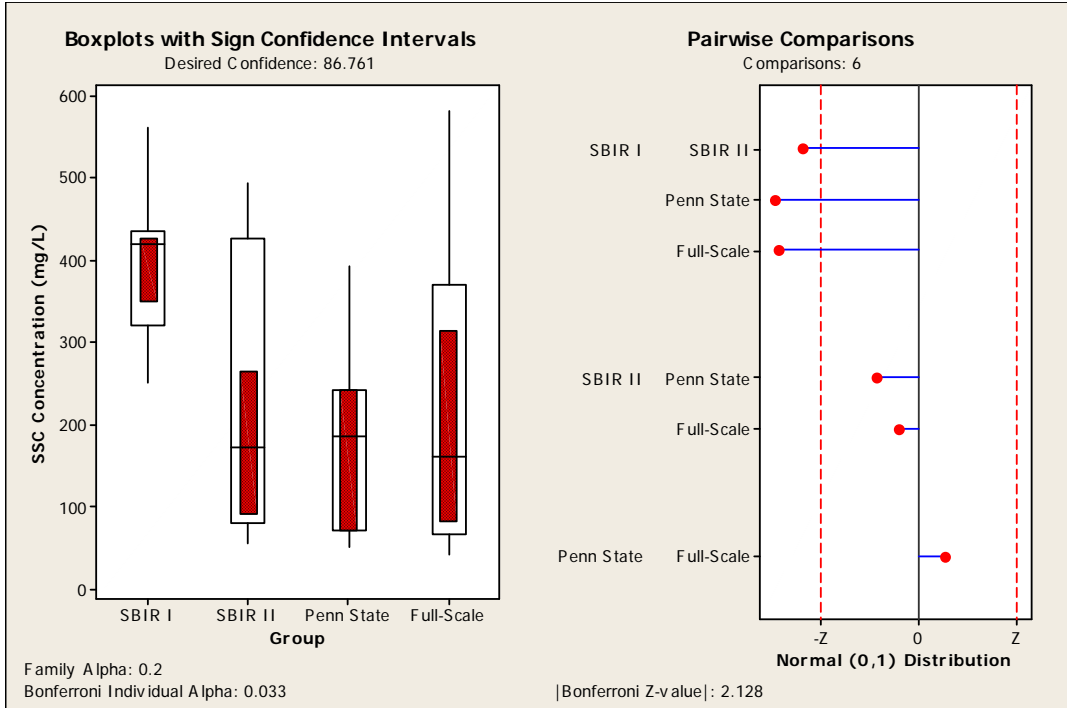

Figure 31. Multiple Comparisons Chart for Influent SSC Concentration

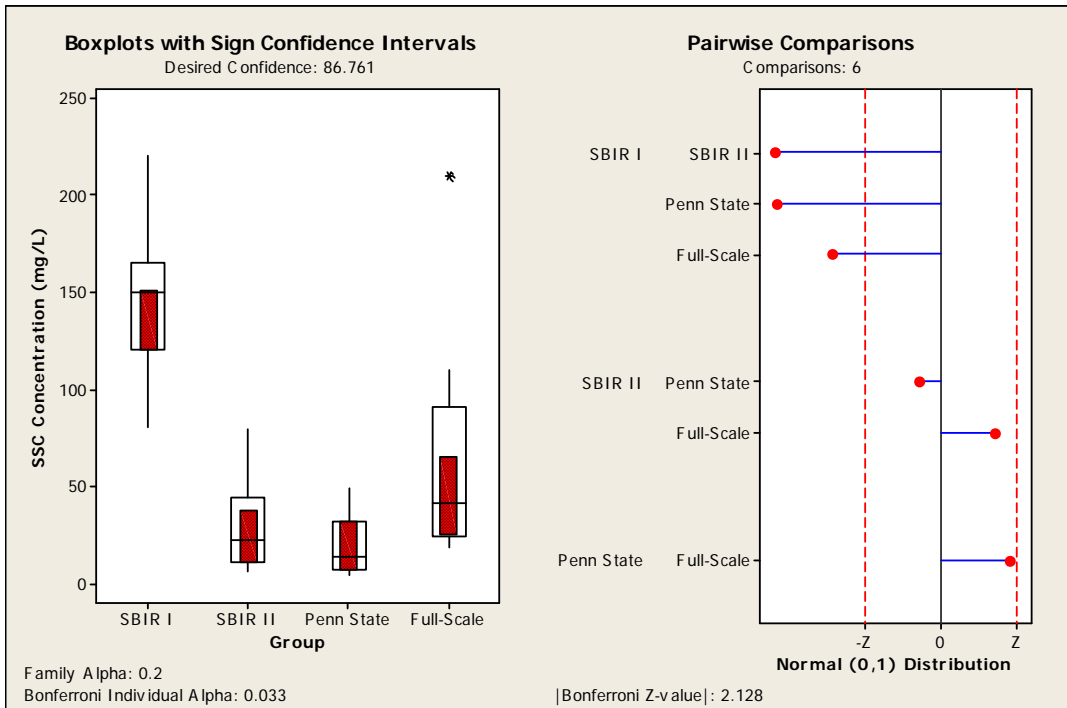

Figure 32. Multiple Comparisons Chart for Effluent SSC Concentration

The graph on the left displays box plots of the groups with their sign confidence intervals for the medians (red boxes in the each box plot). The graph on the right displays the non-absolute group mean rank standardized differences. This latter plot shows the magnitude of the group differences and its direction. It also shows the positive and negative critical z-values and displays if a difference is “significant”. From the above figures, it is seen that the SBIR I project influent and effluent SSC concentrations are positively “larger” than the SBIR II, Penn State, and the Bama Belle Full-Scale test values. This difference is also shown to be statistically significant since the standardized difference distance goes beyond the critical z-values compared to the other test groups. There are no significant differences noted among the SBIR II, Penn State, and Bama Belle Full-Scale tests when the influent and effluent SSC concentrations are compared. This difference is due to the truncated particle sizes and the selected influent concentrations for the SBIR1 tests. It is therefore likely the performance of the SBIR1 tests would be different from the reported performance results from the other tests due to the different influent concentrations. In fact, the resulting effluent concentrations are shown to be significantly different between the SBIR1 and the other tests. Obviously, when comparing performance test results, the basic influent conditions should be similar for the different tests.

4.2.2 *Bama Belle Full-Scale and SBIR II Performance Comparison of UpFlow Filter*

A similar approach was used to distinguish the difference in paired influent and effluent SSC concentrations for the upflow filter. Full particle distributions of influent and effluent sample were available from the SBIR II project, however; there was no detailed analysis data for the SBIR I and the Penn State Harrisburg. Figure 33 shows the multiple comparisons of influent and effluent SSC concentrations for the Bama Belle Full-Scale and SBIR II project tests. The

figure shows that they were statistically significant differences between influent and effluent SSC concentrations for both the Full-Scale and SBIR II project tests. The influent SSC concentrations from the full scale project tests were significantly different from the related effluent SSC concentrations, and the similarly, the influent SBIR II influent SSC concentrations were significantly different from the related effluent concentrations. The next section presents performance plots for the different flows and particle sizes illustrating similarities and differences based on test conditions and scales.

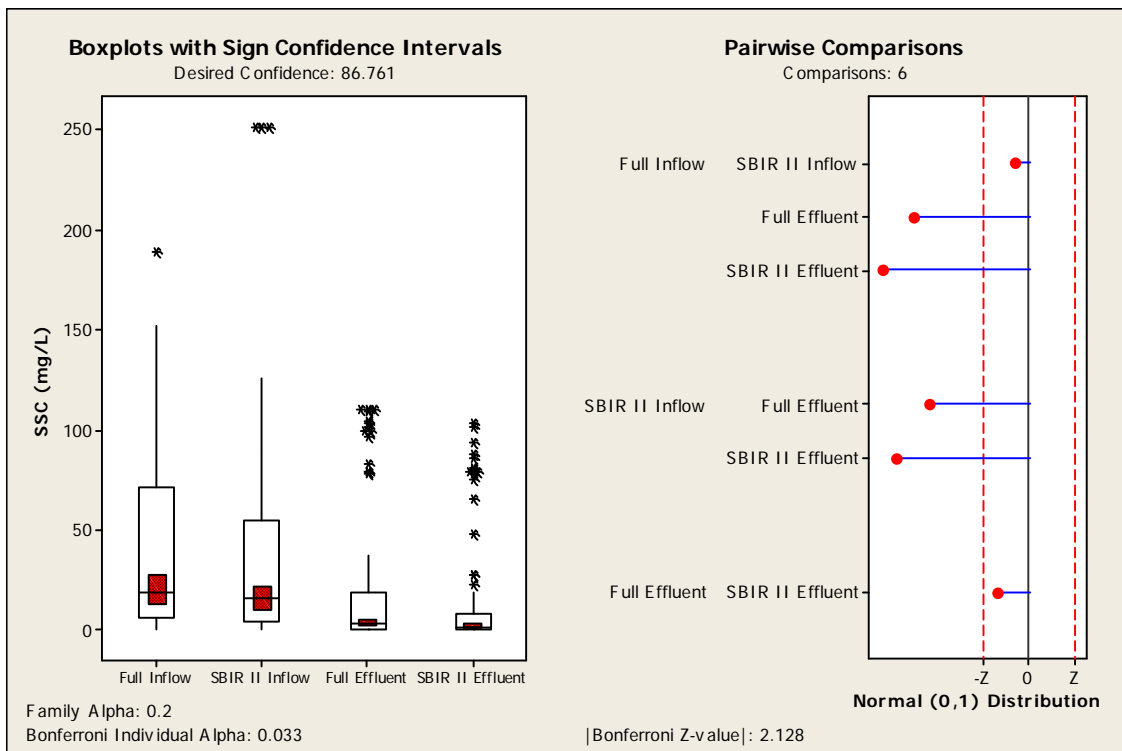

Figure 33. Full-Scale vs. SBIR II Comparison of Influent and Effluent

4.3 Different Flows and Sediment Characteristics for Controlled Conditions

Particle size distribution performance plots for the influent and effluent for the Full-Scale and the SBIR II test were examined below for the different flow rates categories.

4.3.1 *Bama Belle Full-Scale and SBIR II (pilot-scale) Performance for Different Particle Sizes*

The Kruskal-Wallis test was used to calculate the multiple non-parametric statistical significance of the influent and effluent solids concentration for the various tests for each particle size group. Three different flow condition data are separately analyzed separately based on the different particle sizes from less than 0.45 μm up to more than 250 μm . Detailed statistical results are included in Appendix B.4.

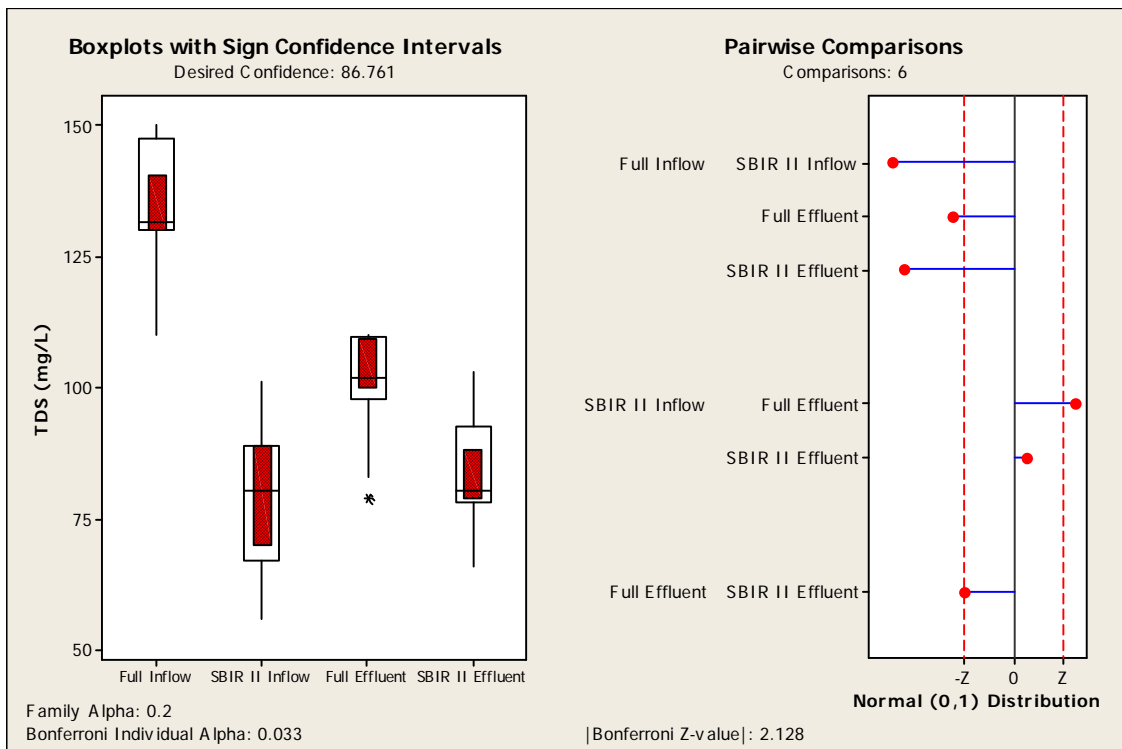

Figure 34. Multiple Comparison Plots for <0.45 μm (TDS) Solids Concentrations

For the dissolved solids ($<0.45 \mu\text{m}$), the influent SSC concentrations of the full-scale tests were much higher than for the SBIR II inflow concentrations. Differences of effluent concentration for both the Bama Belle full-scale and SBIR II tests were statistically not significant.

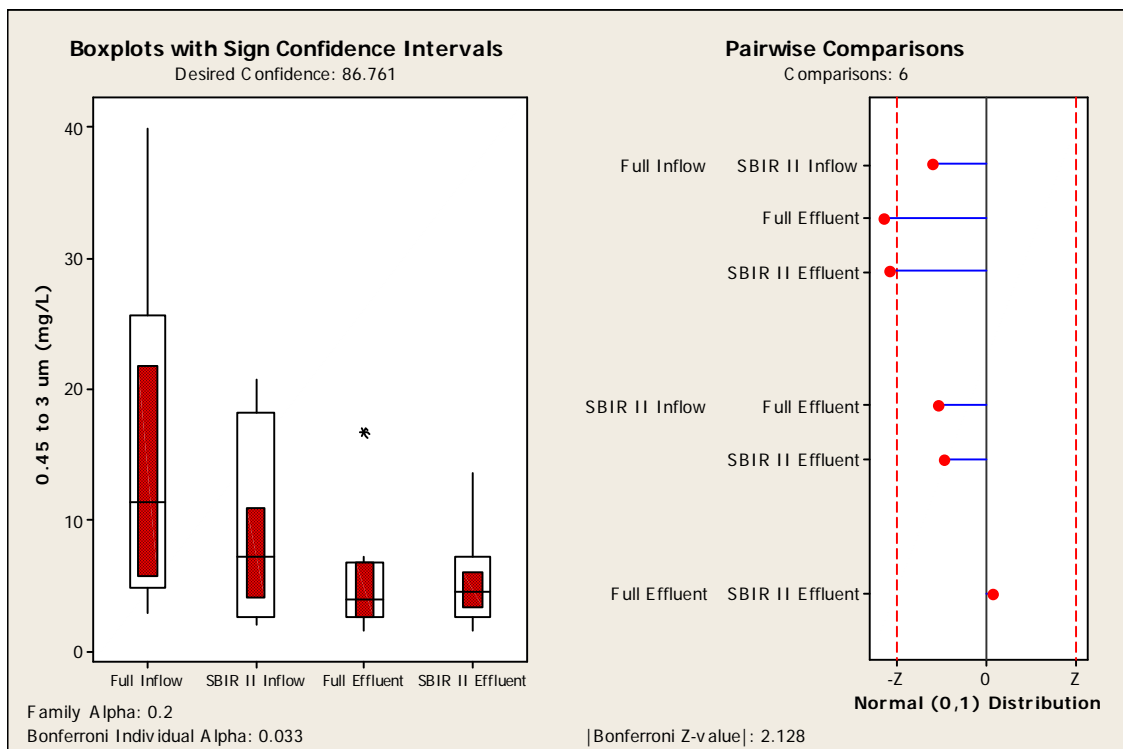

Figure 35. Multiple Comparison Plots for 0.45~3 μm Solids Concentrations

For particle sizes of 0.45 to 3 μm , the influent SSC concentrations of Bama Belle full-scale tests were higher and more variable than for the SBIR II tests. There were no statistically significant differences between the effluent concentration of the full-scale and the SBIR II tests. The lower influent concentrations for the SBIR II tests did not result in significant differences compared to the full-scale or SBIR II effluent SSC concentrations.

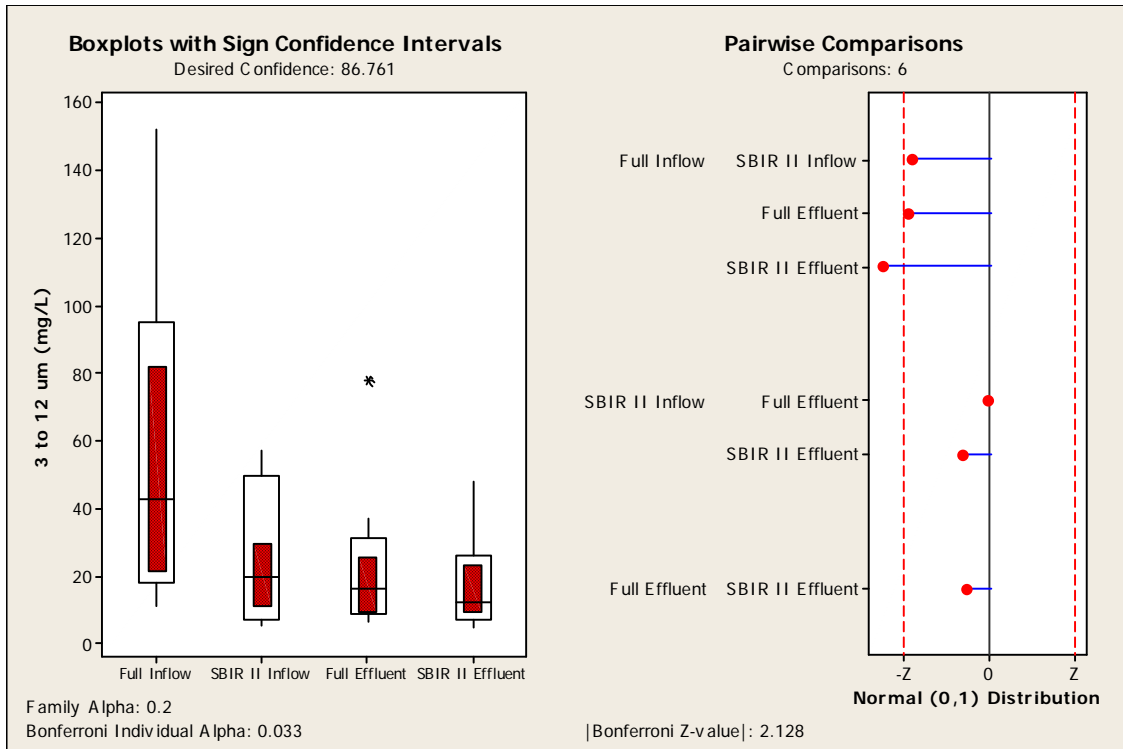

Figure 36. Multiple Comparison Plots for 3~12 μm Solids Concentrations

Results for the 3-12 μm particle size range were similar to the 0.45-3 μm particle sizes. SSC influent concentrations of the full-scale tests were much higher and variable than during the SBIR II tests. These higher concentrations resulted in significant differences compared to effluent concentrations; the lower SBIRII tests influent concentrations were close to the irreducible concentrations and did not indicate any significant differences.

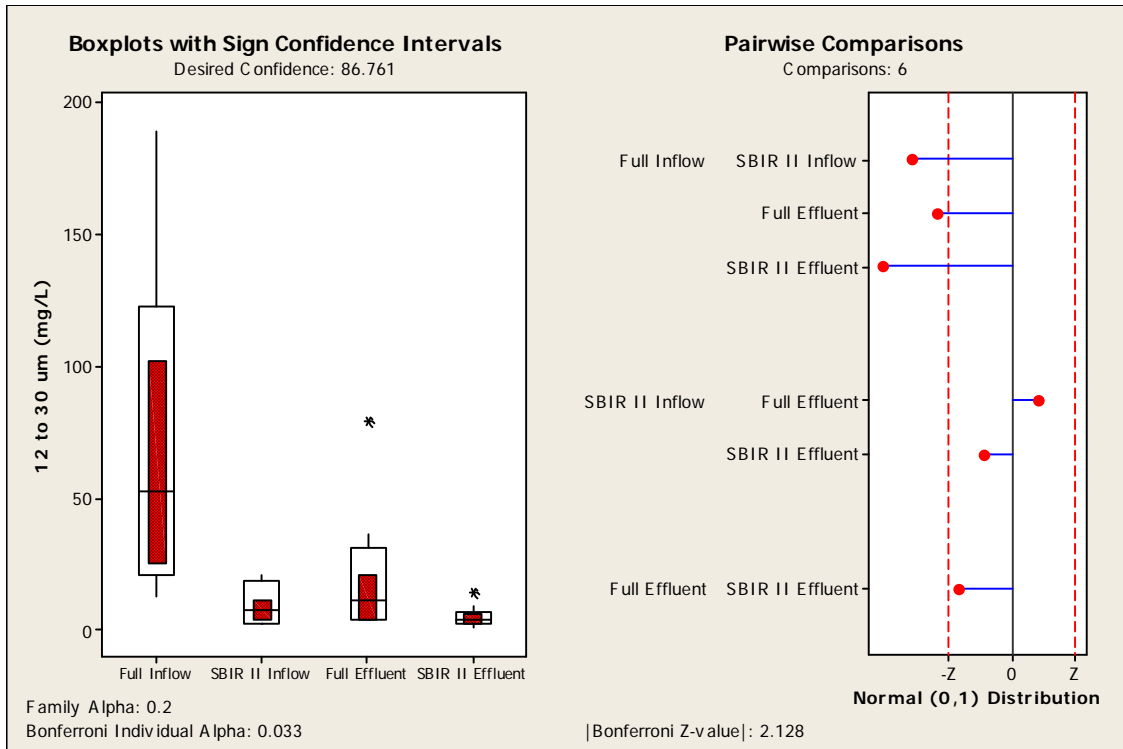

Figure 37. Multiple Comparison Plots for 12~30 μm Solids Concentrations

Influent SSC concentrations during the Bama Belle full-scale tests were highly variable and larger than SBIR II tests for the 12 to 30 μm particle sizes. As before, this resulted in significant differences between influent and effluent for the higher Bama Belle influent concentrations, but not for the lower SBIR II influent concentrations.

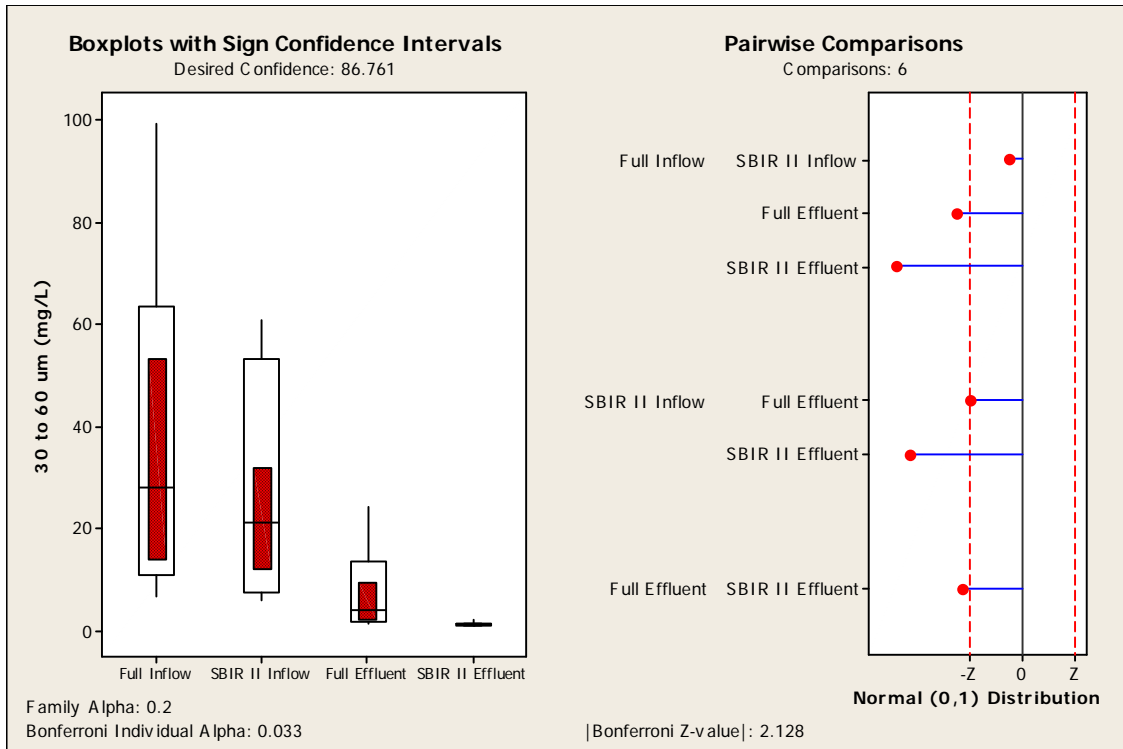

Figure 38. Multiple Comparison Plots for 30~60 μm Solids Concentration

For the particle size 30-60 μm solids size range, the influent concentrations were similar for both the full-scale and pilot-scale tests, and both were significantly larger than the comparable effluent concentrations.

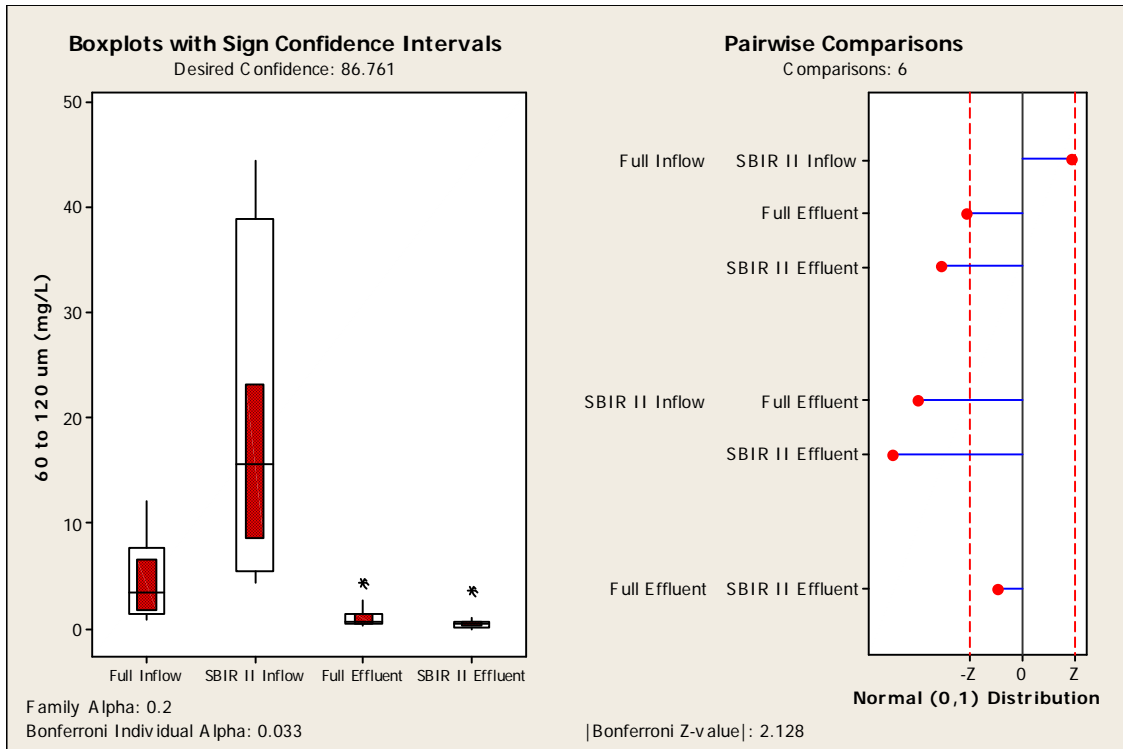

Figure 39. Multiple Comparison Plots for 60~120 μm Solids Concentration

For the particle size 60-120 μm particle size range, the SBIR II influent concentrations were much higher and more variable than for the full-scale tests. Both the Bama Belle full-scale and the SBIR II tests indicated significant reductions of sediments upon treatment.

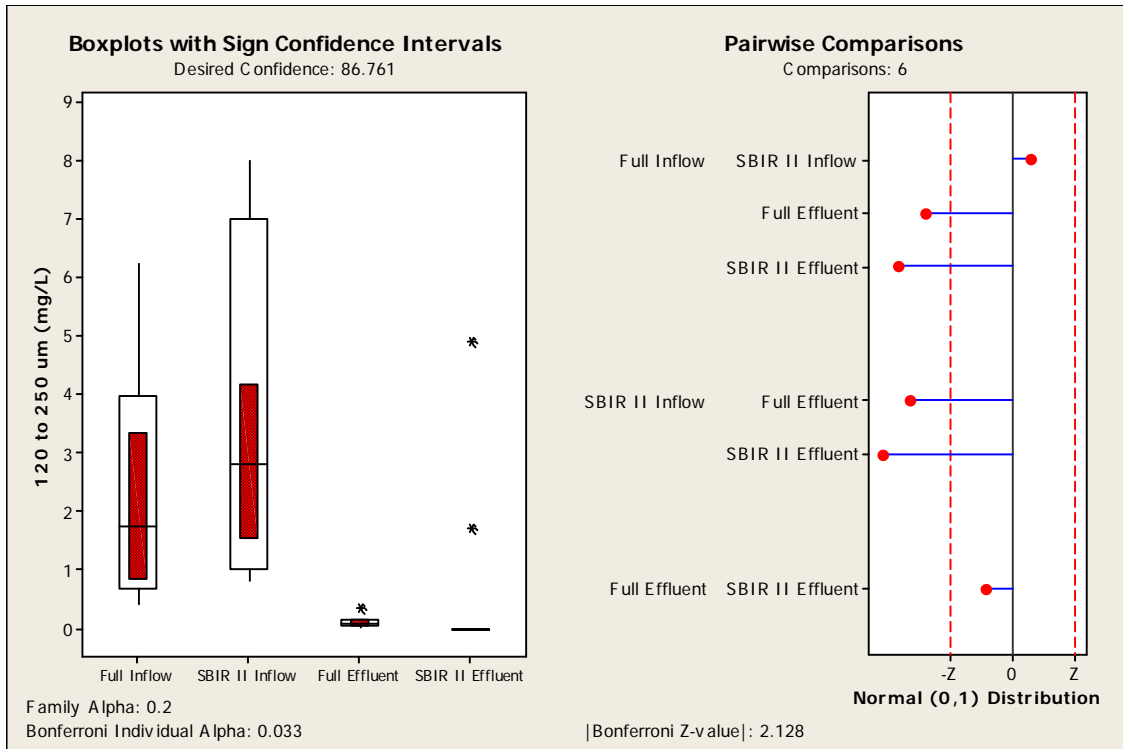

Figure 40. Multiple Comparison Plots for 120~250 μm Solids Concentration

For the larger particle size 120-250 μm range, the influent concentrations for both full-scale and SBIR II tests were similar, and both test series indicated significant reductions with filtering.

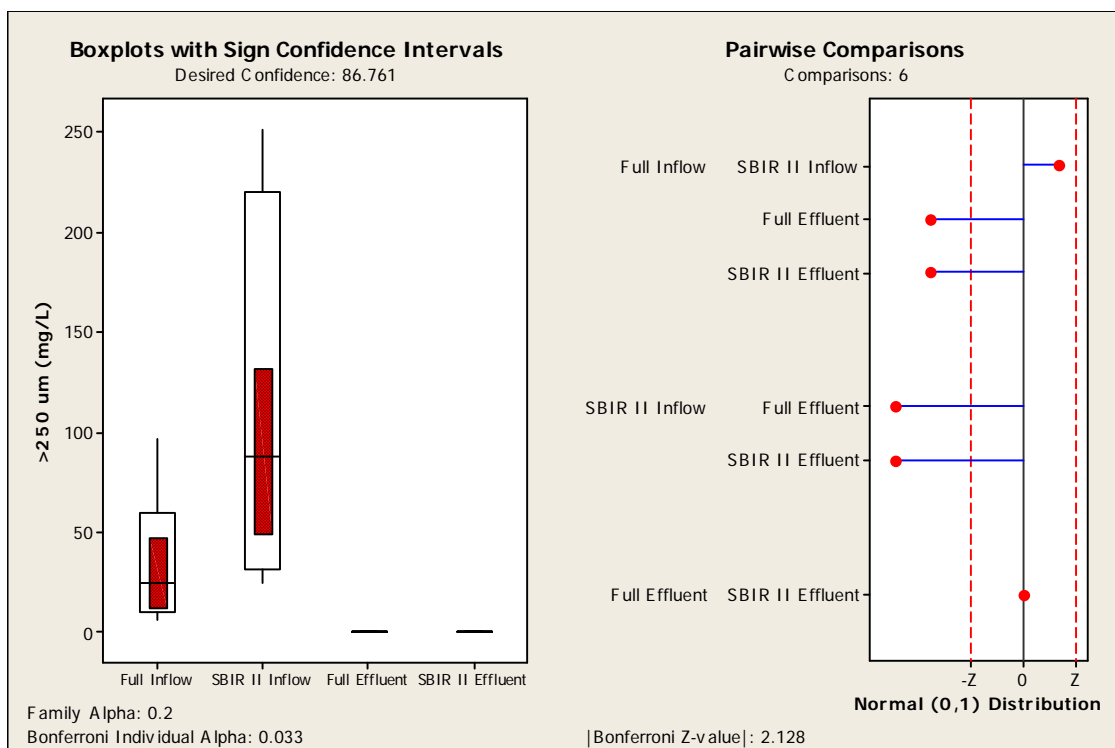

Figure 41. Multiple Comparison Plots for >250 μm Solids Concentration

For the >250 μm particle size range, the SBIR II influent concentrations were highly variable and larger compared to the full-scale test concentrations. The effluent concentrations for these sizes were almost zero, resulting in highly significant reductions and almost 100% removals.

Overall, the effluent concentrations during both the Bama Belle full-scale and the pilot-scale SBIR II tests were similar. The influent concentrations were overlapping, with the full-scale tests having larger influent concentrations for the smaller particles, while the pilot-scale tests had higher influent concentrations for the larger particle sizes. The performance of each test series therefore varied for the small particles due to these different influent concentrations, as the pilot-scale influent concentrations were near the irreducible concentrations, and the full-scale

tests were substantially greater. The overall statistical comparisons were therefore mixed for the small particle ranges (<30 μm) due to these biased concentration ranges and many low influent concentrations, but were clearly consistently different for the larger particle size ranges. The effects of flow were also seen, with more consistent removals to lower concentrations during the lower flow tests compared to the higher flow tests.

The following section will examine the differences in performance for the pilot-scale and the full-scale tests during uncontrolled storm conditions.

4.3.2 *Bama Belle Full-Scale and SBIR II (pilot-scale) Performance for Different Flow Rates*

The particle size distribution plots for the “Low” flow rate conditions (details shown in Appendix I.1) indicate the different particle size distributions for the influent conditions. The SBIR II (pilot-scale) project tests used a much greater percentage of larger particles compared with the Bama Belle full-scale tests. However, the effluent particle size distributions were similar for both test series. This indicates that the pilot-scale and full-scale devices both had similar irreducible removals by particle size and that they both reduced the flows to the same effluent conditions, even under the different test conditions and scales (the effluent median particle sizes were between 5 and 10 μm). Table 28 summarizes the influent and effluent sediment concentrations nonparametric p-values for the “Low” flow rate conditions. In these controlled tests, a flow rate of 25 gpm (3 gpm/ft²) was used for the full-scale setup (5 gpm or 3 gpm/ft², was used for the SBIR II tests).

Table 28. “Low Flow” Nonparametric Test Comparisons for Influent and Effluent Sediment Concentrations

	Full-scale influent vs. pilot-scale influent concs.	Full-scale influent vs. full-scale effluent concs.	Pilot-scale influent vs. pilot-scale effluent concs.	Full-scale effluent vs. pilot-scale effluent concs.
	Actual p value from 2-tailed non paired (Wilcoxon rank sum) nonparametric test	Actual p value from 1-tailed paired (Wilcoxon signed-rank) nonparametric test	Actual p value from 1-tailed paired (Wilcoxon signed-rank) nonparametric test	Actual p value from 2-tailed non paired (Wilcoxon rank sum) nonparametric test
<0.45 μm	0.02	0.01	0.28	0.77
0.45 to 3 μm	0.56	0.04	0.19	0.77
3 to 12 μm	0.56	0.07	0.19	0.39
12 to 30 μm	0.04	0.02	0.07	0.25
30 to 60 μm	0.56	0.01	0.01	0.04
60 to 120 μm	0.04	0.01	0.01	0.77
120 to 250 μm	0.56	0.01	0.01	0.02
>250 μm	0.15	0.01	0.01	1.00

For the larger particle sizes, influent vs. effluent concentration for both full-scale and pilot-scale p-values (second and third column of above table) were close to zero, showing highly significant differences between the influent and effluent solids concentrations. For the smaller particle sizes in the full-scale setup, the p-values were all significant (<0.05), including TDS ($p = 0.01$), but excluding the 3 to 12 μm range ($p = 0.07$). For the smaller particle sizes in the pilot-scale setup, however; p-values were not significant (>0.05) for all particles less than 30 μm , likely due to the much higher treatment unit flow rate. These results showed that the effluent concentrations were all in a narrow range, with the reductions being greater when the influent concentrations were the largest. There did not appear to be much difference in the results from the pilot-scale and the Bama Belle full-scale tests, except for the degraded performance for the

smallest particle sizes at the pilot-scale with the higher flow rates; the influent conditions were extended when both data sets were combined, while the effluent conditions were similar for both sets of tests.

The particle size distribution plots for the “Medium” flow rate were shown in Appendix I.2. The results were similar to the “Low” flow rate conditions in that the influent particle size distributions were different, but similar effluent particle size distributions were observed for both sets of tests. Table 29 displays the influent and effluent sediment concentrations nonparametric p-values for the “Medium” flow rate conditions. A flow rate of 75 gpm (8 gpm/ft²) was used for the Bama Belle full-scale tests and 15 gpm (10 gpm/ft²) was used for the SBIR II (pilot-scale) tests.

Table 29. “Medium Flow” Nonparametric Comparison Tests for Influent and Effluent Sediment Concentrations

	Full-scale influent vs, pilot-scale influent concs.	Full-scale influent vs. full-scale effluent concs.	Pilot-scale influent vs. pilot-scale effluent concs.	Full-scale effluent vs. pilot-scale effluent concs.
	Actual p value from 2-tailed non paired (Wilcoxon rank sum) nonparametric test	Actual p value from 1-tailed paired (Wilcoxon signed-rank) nonparametric test	Actual p value from 1-tailed paired (Wilcoxon signed-rank) nonparametric test	Actual p value from 2-tailed non paired (Wilcoxon rank sum) nonparametric test
<0.45 μm	0.02	0.01	0.07	0.08
0.45 to 3 μm	0.56	0.07	0.28	0.39
3 to 12 μm	0.25	0.07	0.39	1.00
12 to 30 μm	0.04	0.07	0.39	0.15
30 to 60 μm	0.56	0.06	0.01	0.02
60 to 120 μm	0.08	0.04	0.01	0.39
120 to 250 μm	0.56	0.01	0.19	1.00
>250 μm	0.15	0.01	0.01	1.00

As shown in Table 29, smaller solids were not as effectively reduced in the pilot-scale tests, and the smaller particles sizes up to 30 μm had calculated p values larger than 0.05, indicating that not enough data was collected to show a significant difference between the influent and effluent concentrations. However, the higher concentrations in the influent were reduced to much lower levels. Statistically significant differences were evident for the particle sizes larger than 30 μm for the “Medium” flow conditions.

High flow rate tests were conducted with flow rates of 150 gpm (17 gpm/ft^2) for the full-scale tests and 27 gpm (18 gpm/ft^2) for the SBIR II (pilot-scale) tests. The particle size distribution plots for high flow rates were described in Appendix I.3. The particle size distributions during these tests indicated larger median particle sizes for the SBIRII tests than for the Bama Belle full-scale tests, as indicated for the low and medium flow tests above. Also, as found before, the effluent particle size distributions were similar for both series of tests. Table 30 is the high flow rate influent and effluent sediment concentration comparisons calculated nonparametric p-values.

Table 30. “High Flow” Nonparametric Test for Influent and Effluent Sediment Concentrations

	Full-scale influent vs, pilot-scale influent concs.	Full-scale influent vs. full-scale effluent concs.	Pilot-scale influent vs. pilot-scale effluent concs.	Full-scale effluent vs. pilot-scale effluent concs.
	Actual p value from 2-tailed non paired (Wilcoxon rank sum) nonparametric test	Actual p value from 1-tailed paired (Wilcoxon signed-rank) nonparametric test	Actual p value from 1-tailed paired (Wilcoxon signed-rank) nonparametric test	Actual p value from 2-tailed non paired (Wilcoxon rank sum) nonparametric test
<0.45 μm	0.02	0.01	0.39	0.02
0.45 to 3 μm	0.25	0.12	0.39	0.77
3 to 12 μm	0.15	0.19	0.50	0.56
12 to 30 μm	0.04	0.07	0.39	0.25
30 to 60 μm	0.56	0.12	0.01	0.04
60 to 120 μm	0.15	0.12	0.01	0.08
120 to 250 μm	0.56	0.01	0.01	0.02
>250 μm	0.15	0.01	0.01	1.00

These results were similar to the medium flow rates tests, with decreased performance for the smaller particles compared to the larger particle sizes. Insufficient data were available to indicate significant differences between the influent and effluent concentrations for particle sizes less than 30 or larger than 120 μm , but highly significant differences in the concentrations were found for the larger particle sizes. Even for the small particle sizes, the high influent concentrations were greatly reduced.

4.4 Performance Test Comparisons during Actual Storm Conditions Having Varying Flows and Influent Sediment Characteristics

Stormwater treatment measurements during actual storm conditions having varying sediment and flow characteristic are discussed in this section. Bama Belle full-scale and SBIR II pilot-scale tests both had full particle size analyses for each tested event. These data were used to calculate the performance of the device under these highly variable conditions. Table 31 summarizes the rain and flow event characteristics for the full-scale and SBIR II monitored storms. The SBIR II test site was located approximately 2 miles from the full-scale Bama Belle site, and the tests were conducted during different years. Detailed analyses are included in Appendix C.

Table 31. Summary Table for Storm Events of Full and SBIR II

		Bama Belle Full-Scale Tests	SBIR II Pilot-Scale Tests
Number of Samples*		20	31
Monitoring Period		July 2010 to April 2011 (10 months)	February 2005 to November 2005 (10 months)
Rain Depth (in)	average	0.62	0.74
	max	1.48	3.2**
	min	0.11	0.02
	standard dev	0.37	0.80
	COV	0.59	1.08
Average Rain Intensity (in/hr)	average	0.2	0.18
	max	0.51	0.70
	min	0.03	0.01
	standard dev	0.1	0.16
5-minute Peak Rain Intensity (in/hr)	average	1.4	1.45
	max	3.0	4.32
	min	0.12	0.12
	standard dev	1.1	1.31
Rain Duration (hr)	average	3.6	4.7
	max	6.33	23.0
	min	1.17	0.3
	standard dev	1.6	4.8
5-minute Peak Runoff Rate (cfs)	average	0.7	0.368
	max	2.16	1.57
	min	0.04	0.04
	standard dev	0.6	0.39

* some of the pilot-scale samples were obtained during the same event, while all of the full-scale samples were total event flow-weighted samples.

** the largest single rain during the pilot-scale tests was associated with Hurricane Katrina.

4.4.1 *Bama Belle Full-Scale and SBIR II (pilot-scale) Particulate
Characteristic under Actual Storm Conditions*

Figure 42 displays the box plot for the 0.45 μm particle size influent and effluent concentrations during the full-scale and SBIR II storm event monitoring period.

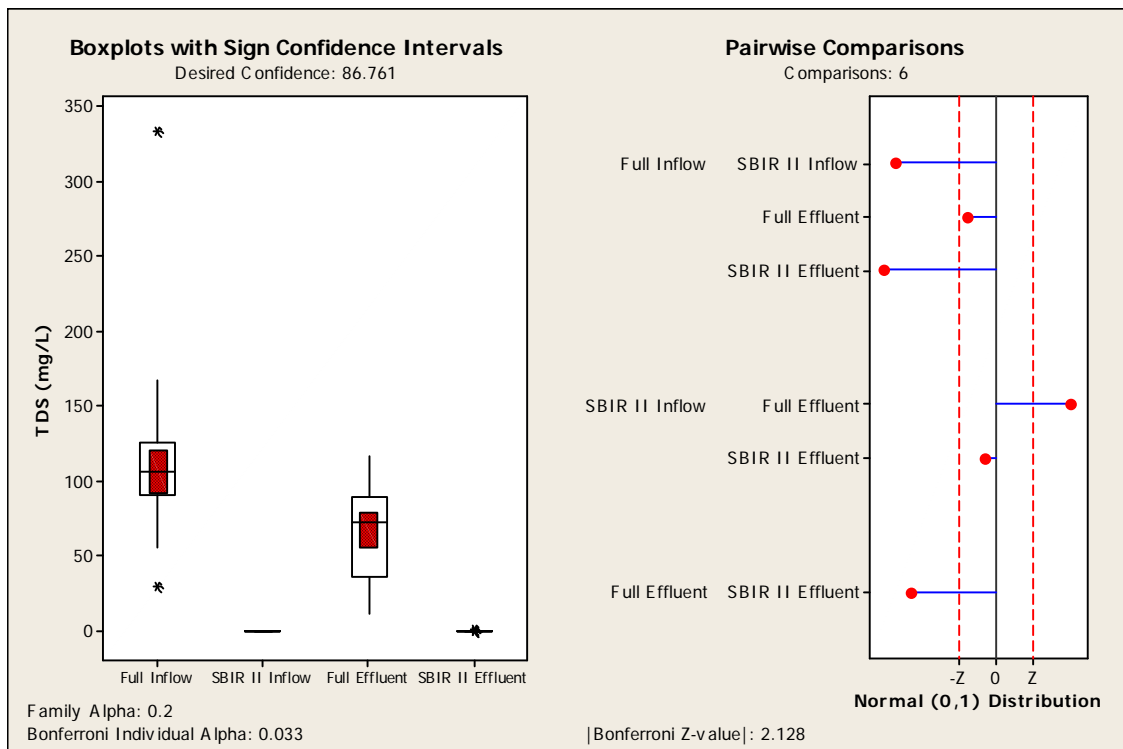

Figure 42. Multiple Comparison Plots for <0.45 μm (TDS) Influent and Effluent Solids Concentrations for Monitored Storms

During the actual storm events, the Bama Belle full-scale test site had much larger <0.45 μm (TDS) concentrations compared with the SBIR II test site. Influent and effluent concentrations at each site did have a significant difference and the full-scale and pilot-scale each had significant differences when the influents were compared to the effluent conditions. As

indicated on Figure 42, SBIR II had less variable influent and effluent dissolved solid concentration compared with the full-scale test.

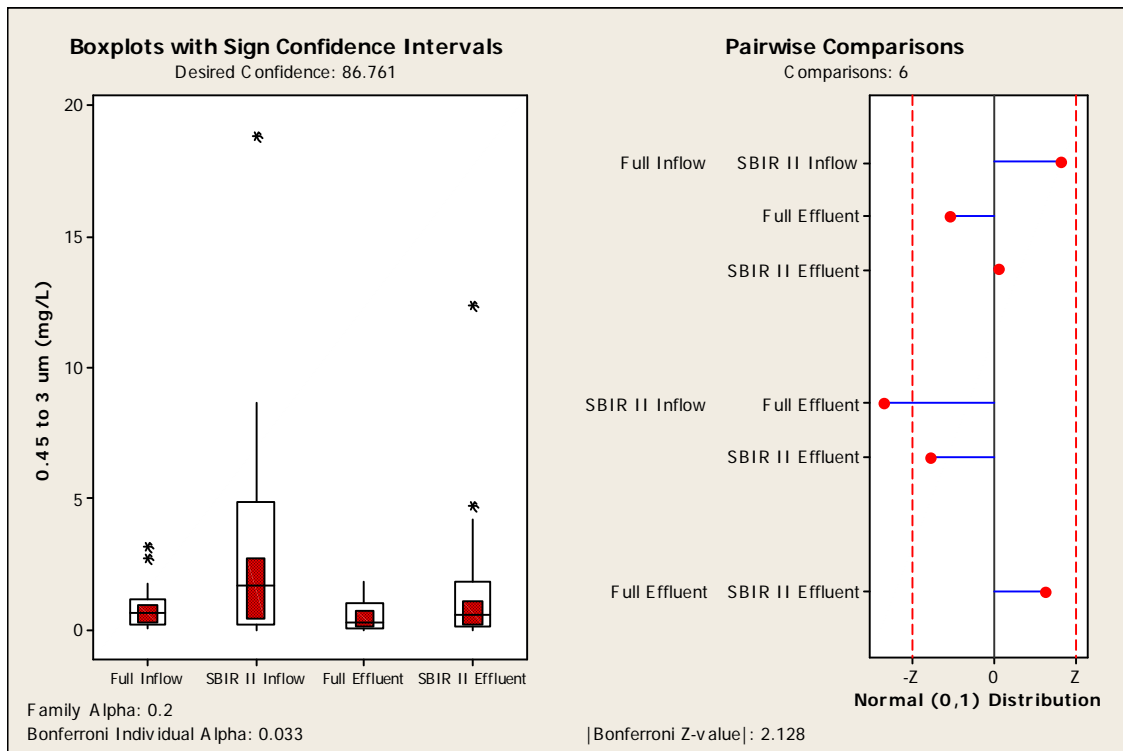

Figure 43. Multiple Comparison Plots for 0.45-3 μm Solids Concentration for Monitored Storms

For the 0.45-3 μm particle sizes, there were no significant differences for the influent and effluent concentrations for both the full-scale and SBIR II monitored rains. The full-scale observations had smaller variations in the influent and effluent concentrations compared with the SBIR II observations.

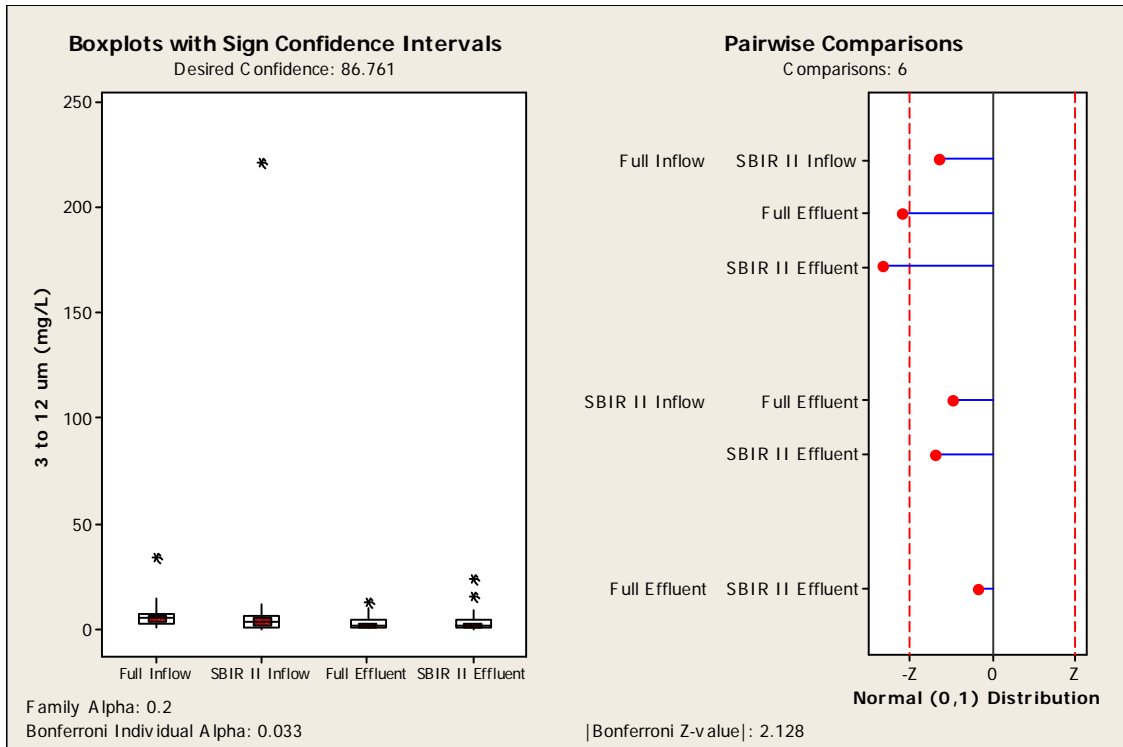

Figure 44. Multiple Comparison Plots for 3-12 μm Solids Concentration for Monitored Storms

For the 3-12 μm solids category, the full-scale influent and effluent concentrations were significantly different, while the pilot-scale data were close to the irreducible concentrations for these sizes and did not indicate any significant differences.

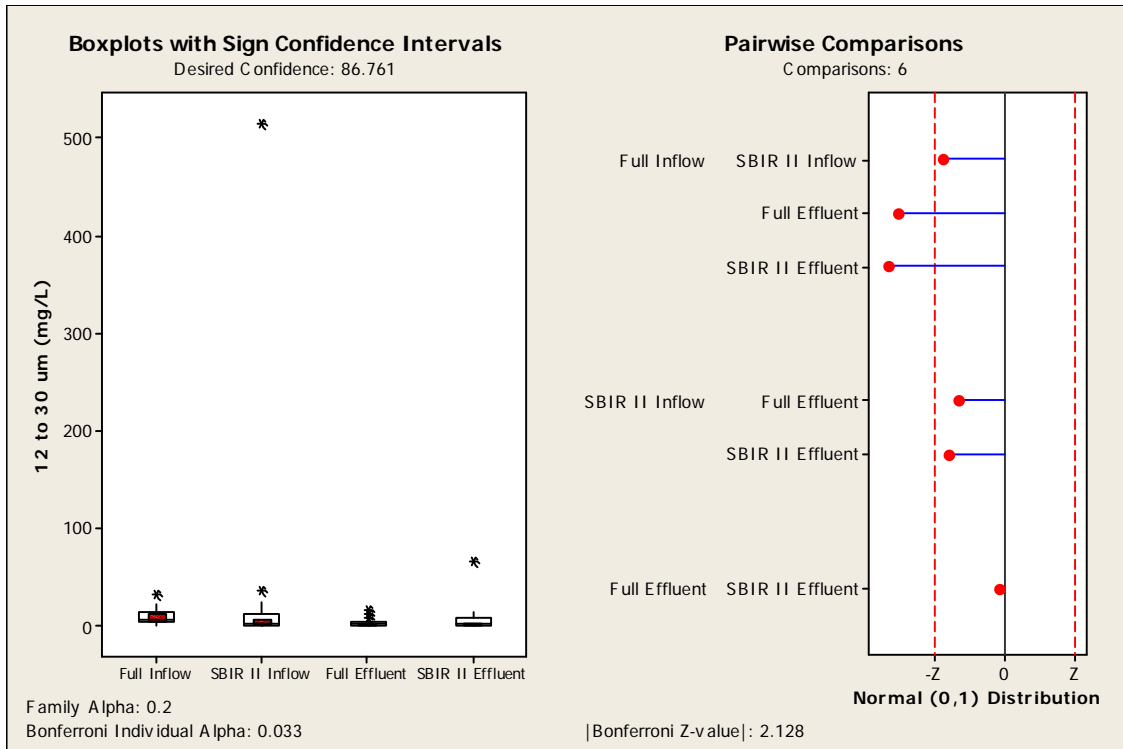

Figure 45. Multiple Comparison Plots for 12-30 μm Solids Concentration for Monitored Storms

There were statistically significant differences between the influent and effluent concentrations for the full-scale test for the 12-30 μm solids size range. Again, the pilot-scale influent concentration data were close to the irreducible concentrations and did not indicate a significant reduction.

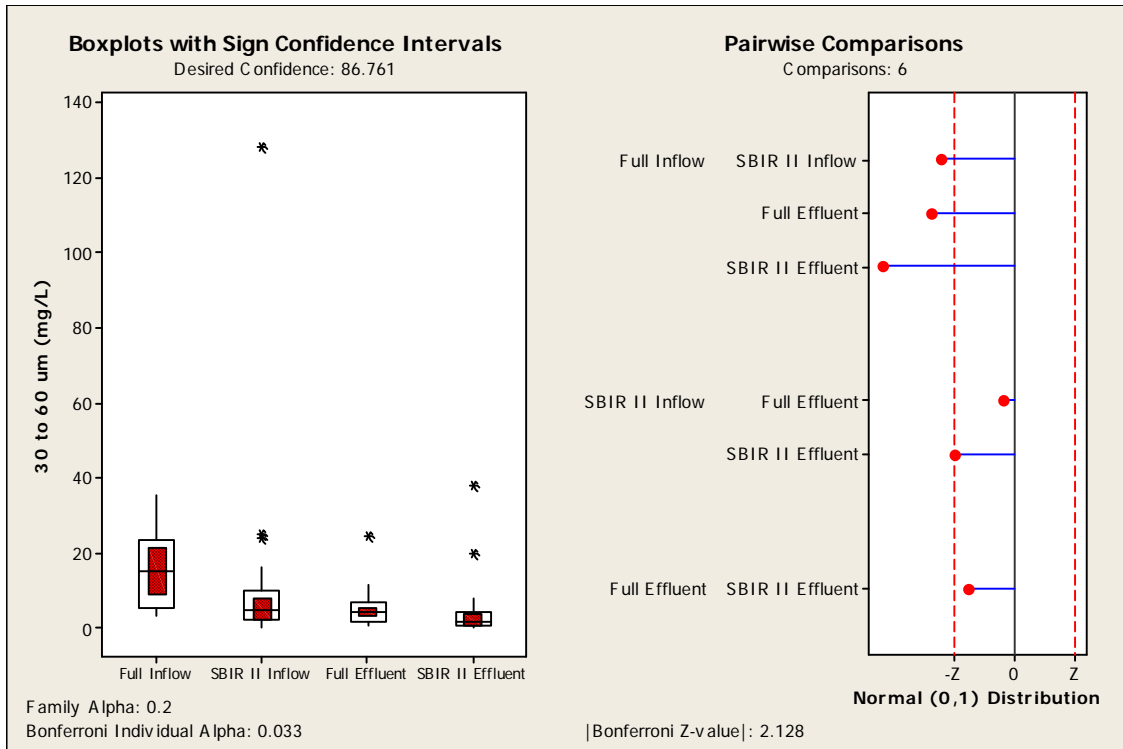

Figure 46. Multiple Comparison Plots for 30-60 μm Solids Concentration for Monitored Storms

For the particles in the 30-60 μm range, the influent concentrations were significantly different that the effluent concentrations for both the full-scale and the SBIR II monitored storms. As for all data presented, the effluent concentrations for both locations were not significantly different from each other, indicating performance down to the likely irreducible concentrations.

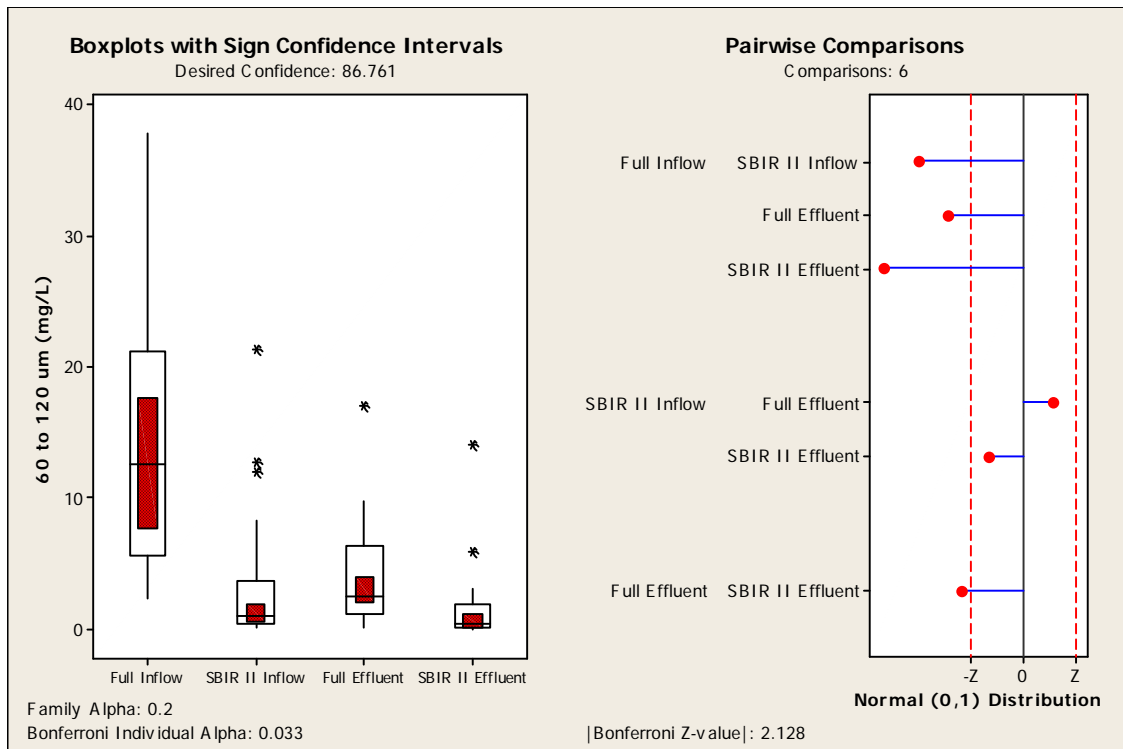

Figure 47. Multiple Comparison Plots for 60-120 μm Solids Concentration for Monitored Storms

The full-scale influent concentrations for the 60-120 μm range were higher and more variable than for the SBIR II inflow concentration data. The full-scale observations indicated a significant difference between influent and effluent concentrations, but not for the pilot-scale tests. The effluent concentrations for both sites were also not significantly different.

Overall, the upflow filter demonstrated treatability under a wide range of flow and sediment characteristics, with more significant removals for larger particles and for higher concentrations.

4.4.2 *BamaBelle Full-Scale and SBIR II Pilot-scale Observations for Other Constituents during Actual Storm Conditions*

Other constituents such as the turbidity, COD, phosphorus, nitrates, ammonia, E-coli, Enterococci, TSS, and SSC were analyzed for the full-scale and SBIR II storm observations. Detailed analyses are included in Appendix D.

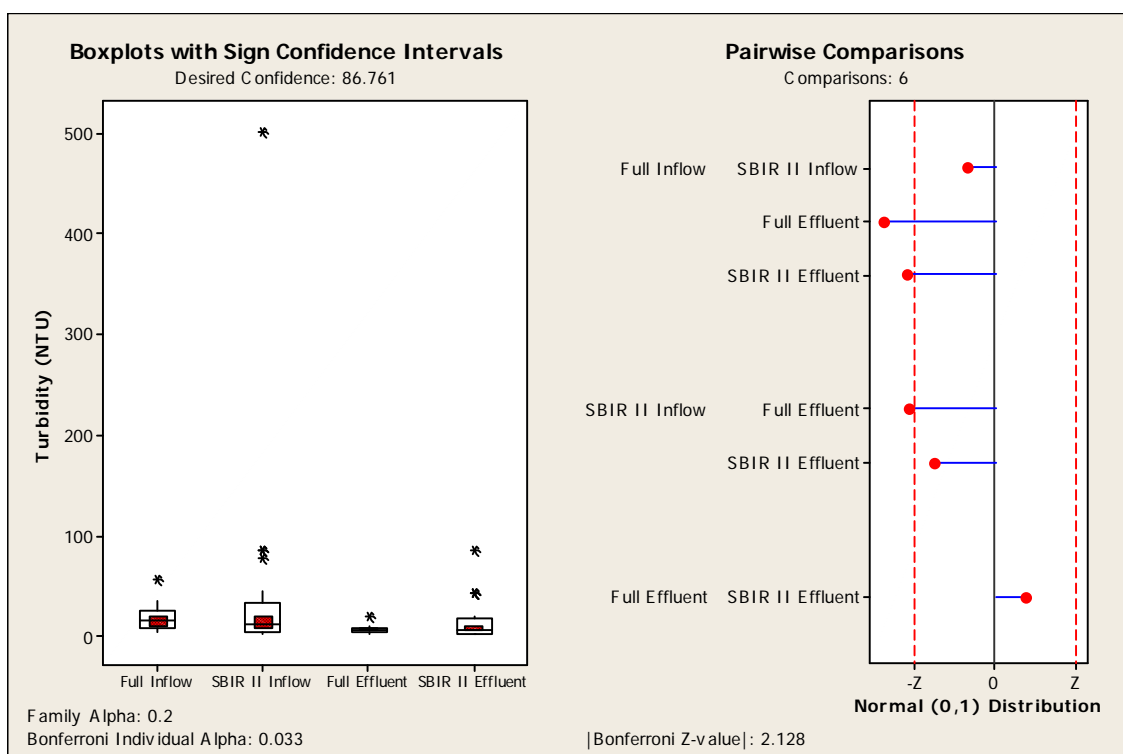

Figure 48. Multiple Comparison Plots for Turbidity for Monitored Storms

Turbidity levels of the influent and effluent samples were both significantly different for the full-scale and SBIR II storm observations. The effluent turbidity levels were not significantly different for the two sites. The turbidity variability for the influent observations were also less than for the SSC concentrations.

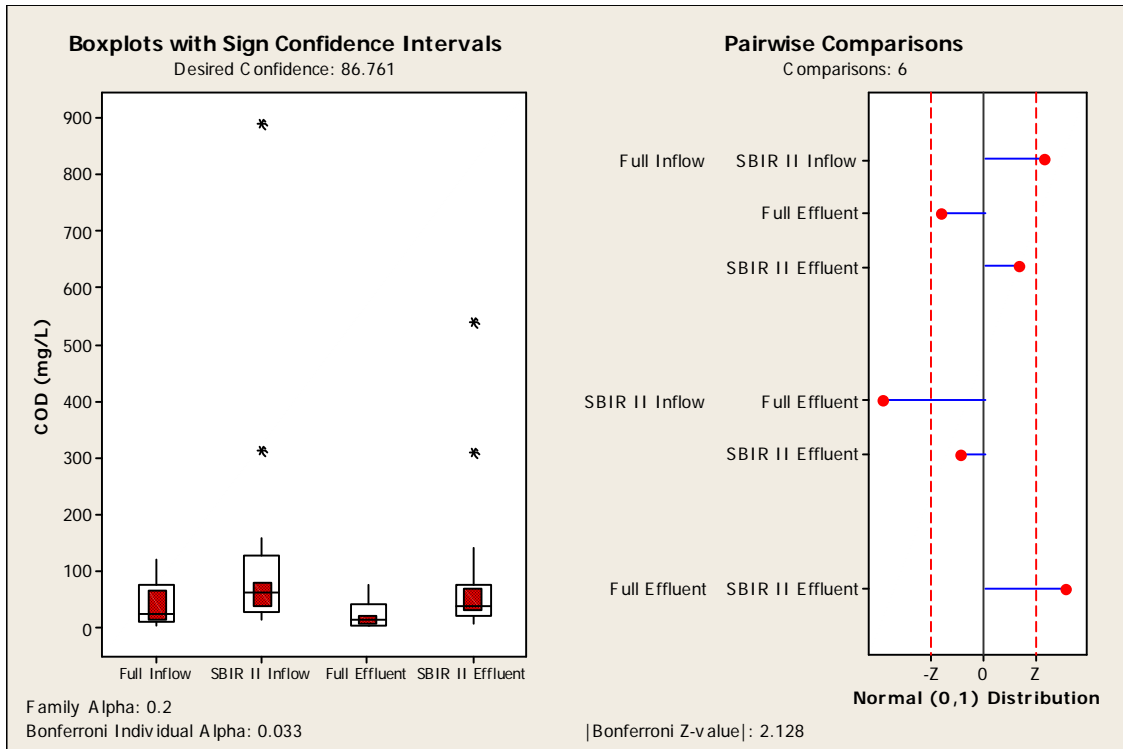

Figure 49. Multiple Comparison Plots for COD for Monitored Storms

There were no statistically significant differences noted between the influent and effluent COD concentration observations at the 0.05 confidence level for either the full-scale or SBIR II observations. The COD reductions were calculated to be between 20 to 70%, but the variability requires additional data to indicate significant reductions.

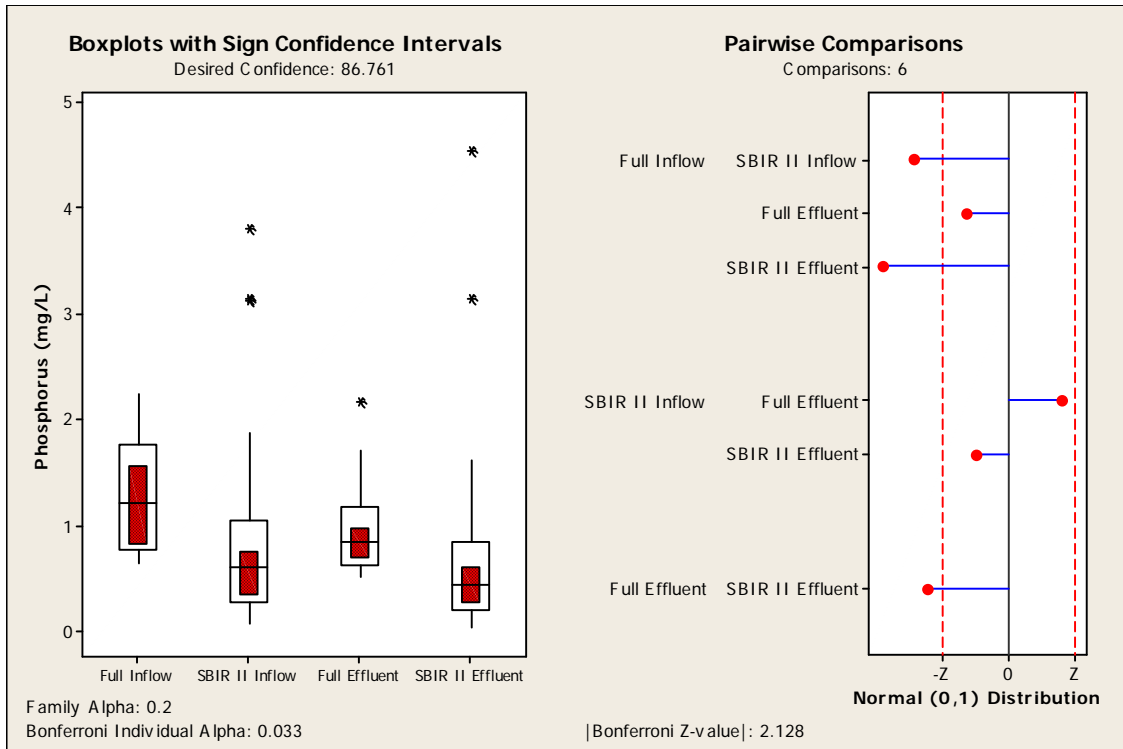

Figure 50. Multiple Comparison Plots for Phosphorus for Monitored Storms

Phosphorus influent characteristics for the full-scale and SBIR II were statistically different for the two test sites, with the full-scale observations having much higher concentrations of phosphorus compared with the SBIR II, likely due to adjacent landscaping maintenance. There were no significant differences between the influent and effluent concentrations for either location at the 0.05 confidence level. The full-scale effluent phosphorus concentrations were also greater than for the pilot-scale observations, corresponding to the higher influent concentrations.

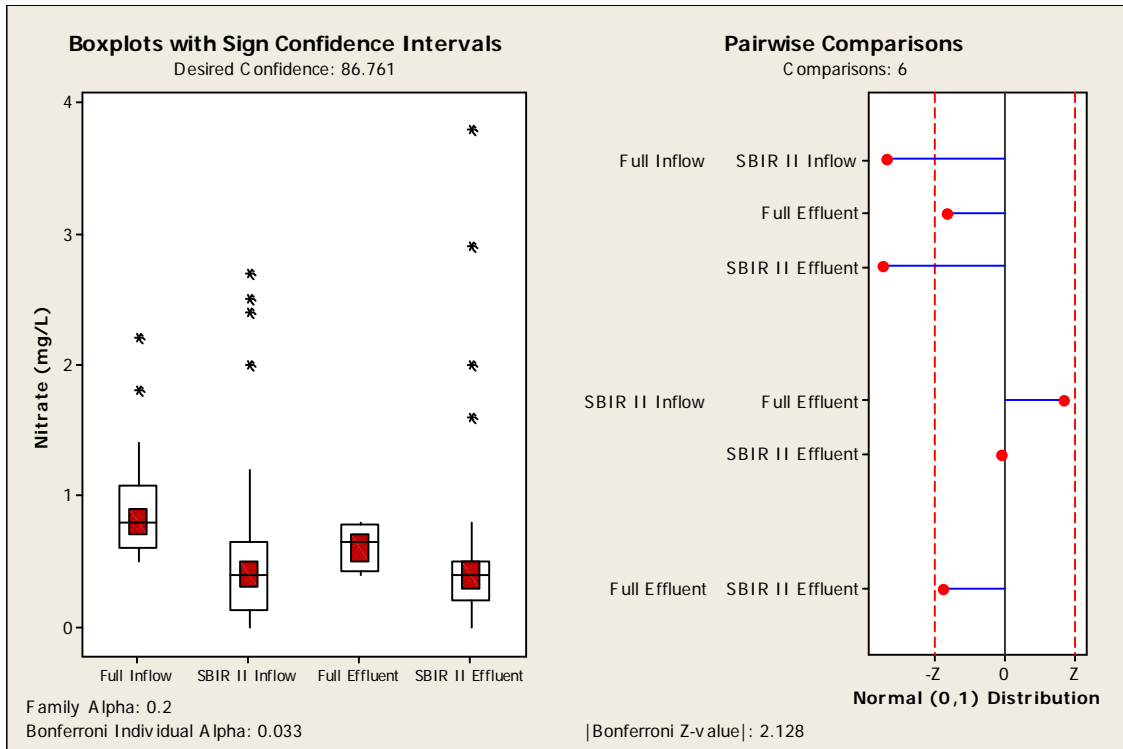

Figure 51. Multiple Comparison Plots for Nitrates for Monitored Storms

Nitrate influent characteristics were significantly different at both sites, possibly related to the landscaping maintenance at the full-scale test site. No significant differences were indicated between the influent and effluent nitrate concentrations.

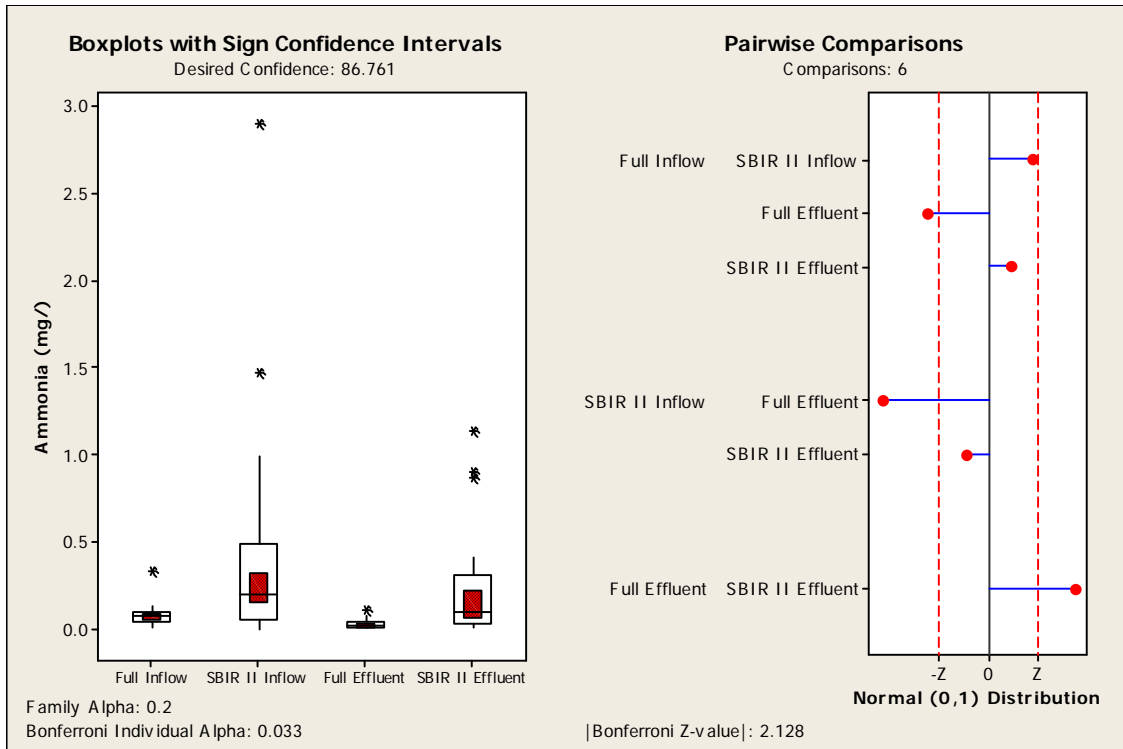

Figure 52. Multiple Comparison Plots for Ammonia for Monitored Storms

The full-scale observations for ammonia found significantly different effluent concentrations, while the pilot-scale test did not.

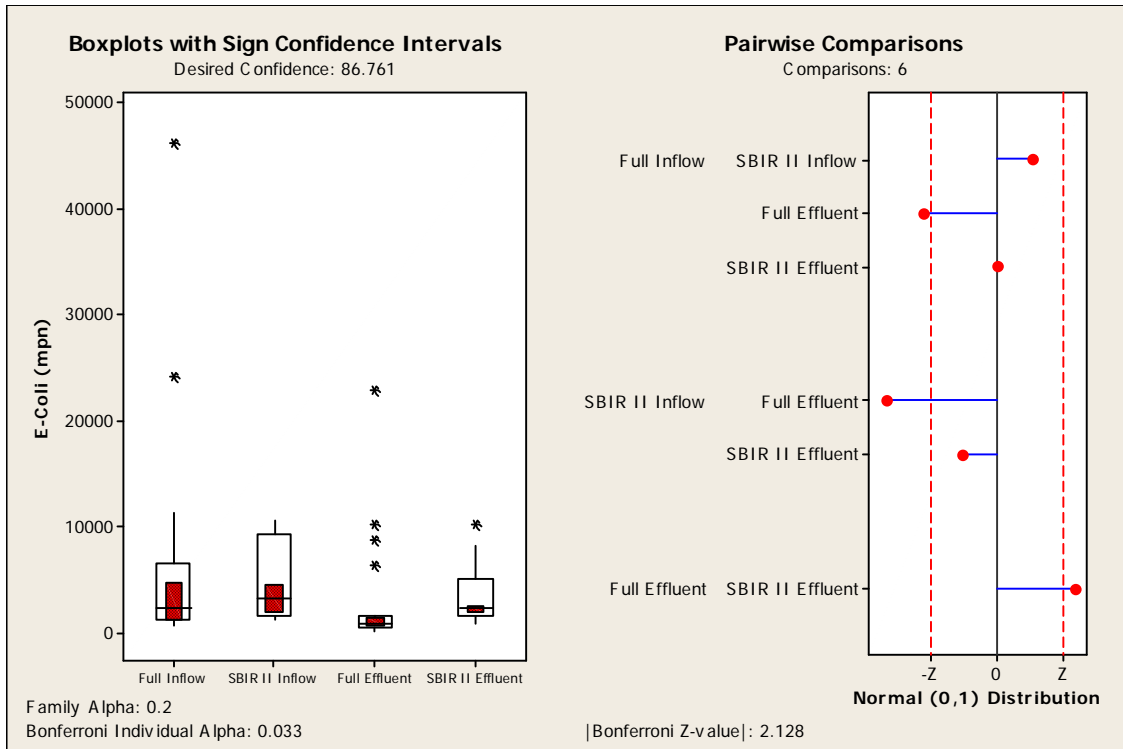

Figure 53. Multiple Comparison Plots for E-Coli for Monitored Storms

The Bama Belle full-scale and the pilot-scale influent *E. coli* influent values were not significantly different, while the full-scale effluent values were significantly less than the influent values. The pilot-scale tests did not detect any significant differences between the influent and effluent *E. coli* values. The effluent values from both test series were significantly different, with the SBIR II pilot-scale effluent values being larger.

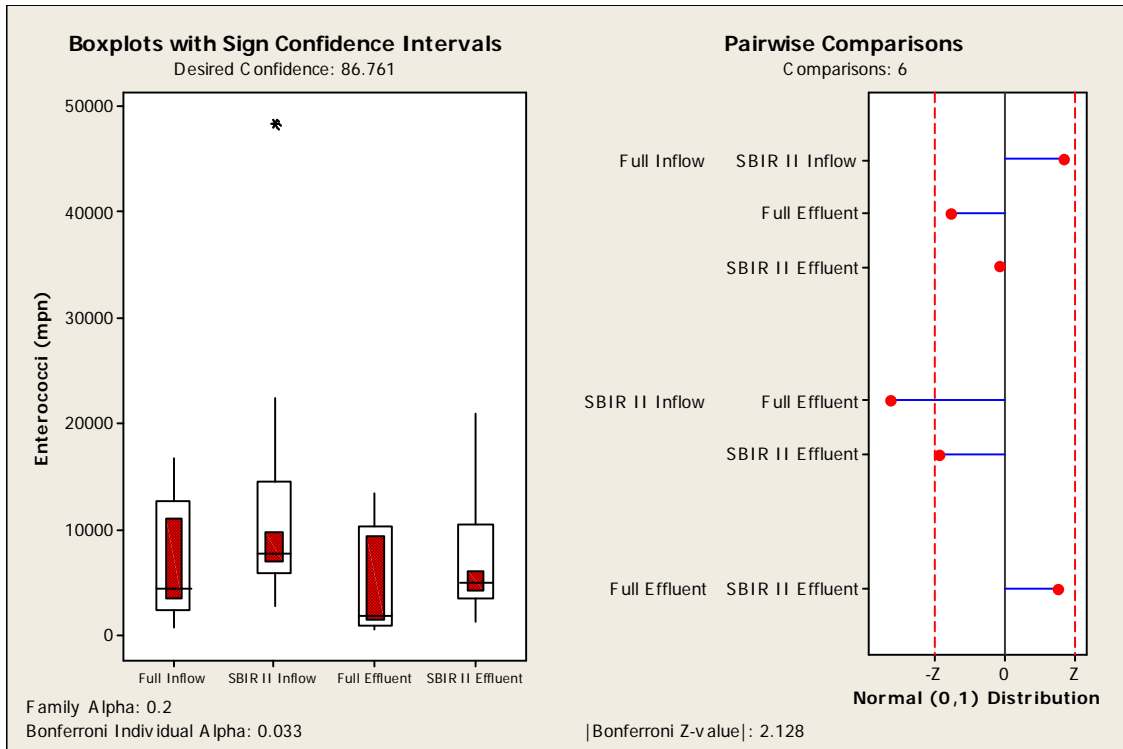

Figure 54. Multiple Comparison Plots for Enterococci for Monitored Storms

Influent and effluent enterococci values for both the Bama Belle full-scale and the SBIR II pilot-scale tests were not significantly different. The influent and effluent values for both tests were not shown significant differences.

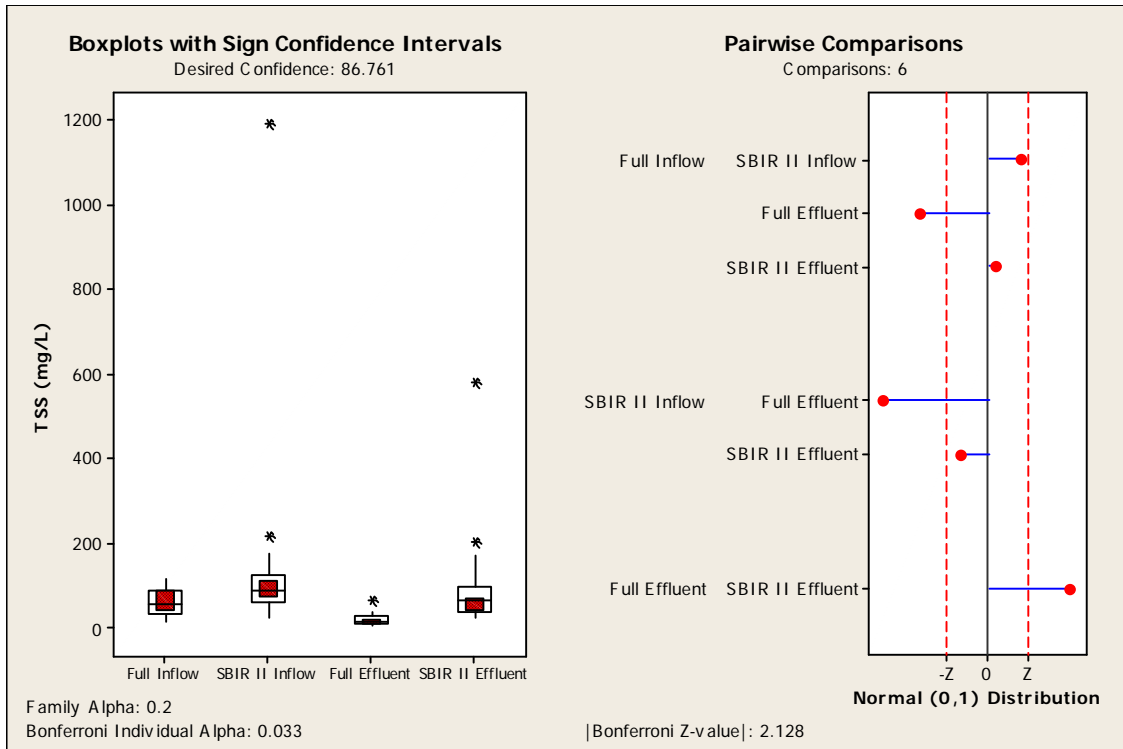

Figure 55. Multiple Comparison Plots for TSS for Monitored Storms

Influent and effluent TSS values for both the Bama Belle full-scale and the SBIR II pilot-scale tests were significantly different in concentrations. The influent values for both tests were also not shown to be significantly different, but the effluent concentrations were significantly different from each other.

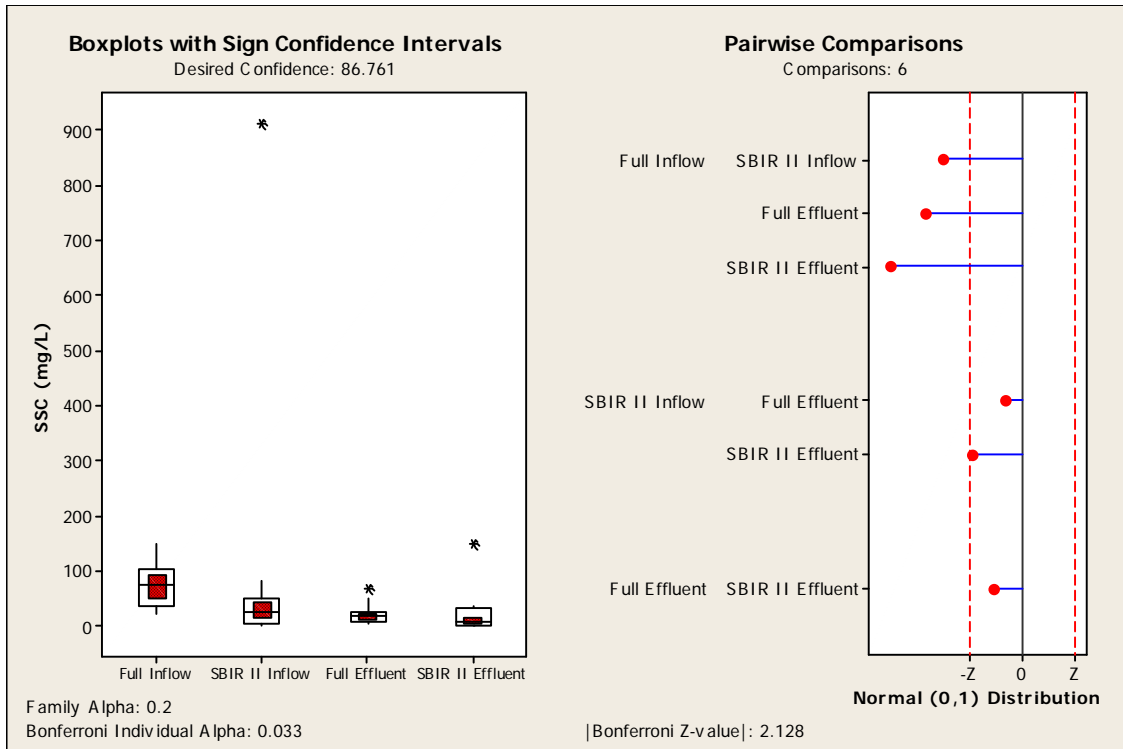

Figure 56. Multiple Comparison Plots for SSC for Monitored Storms

The Bama Belle full-scale and the pilot-scale influent SSC values were significantly different, while the full-scale and the pilot-scale effluent values were not significantly different based on the available data.

4.5 Treatment Flow Rate Change with Operation of the Technology

The treatment flow rate was compared for the Bama Belle full-scale (6 module unit), PSH full-scale (one module unit), and the SBIR II pilot-scale unit. Figure 57 indicated the flow vs. head graph for these tests, normalized by filter area. Each system contains from one to six filter modules, with each module having a treatment flow rate of about 20 to 30 gal/min/ft².

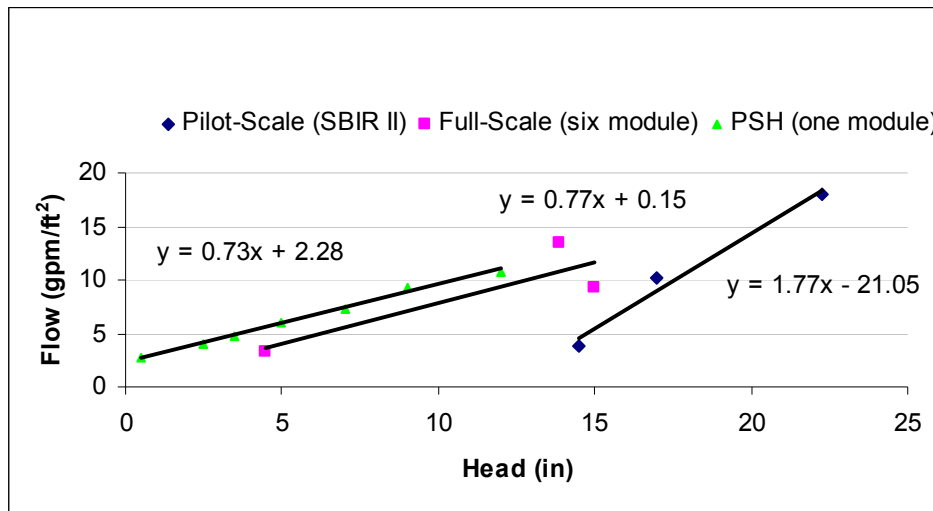

Figure 57. Flow vs. Head Graph for Full-Scale and SBIR II

4.6 Applicable State Criteria Analysis

The four main treatment device test protocols (and which are discussed here) were based on state or other political jurisdictions and do not consider difference in stormwater characteristics (such as by land use) and storm patterns that vary by geographical region. Regional differences of stormwater characteristics and local problems should be a consideration in the protocols. The National Stormwater Quality Database (NSQD), developed by Pitt, et al. (2008) has stormwater data from more than 8,500 events representing about 100 municipalities throughout the country. The NSQD has been used to describe stormwater characteristics as a function of various factors, including land use, geographical region, and season. As indicated in the previous discussions, performance of stormwater controls was highly dependent on influent water quality and flow rate, with better removals associated with high concentrations and low flows, for example.

During the research testing of the Bama Belle full-scale upflow filter, the preliminary data plus the monitoring data represented a total of 27 separate rains, representing the influent pollutant concentrations expected at the monitoring location. The SBIR II pilot-scale data collected by Khambhammettu (2006) included a total of 31 samples, with some collected from different portions of the same rain events. These data were compared to the NSQD data to determine if the Bama Belle and the SBIR II sites represent the regional stormwater characteristics, and to determine how many random events are needed in a study period to adequately represent this regional data. These were then compared to the guidelines presented in the protocols to determine their ability to represent regional data.

Khambhammettu's data collection site (the SBIR II pilot-scale tests) was located at the parking area adjacent to the new City Hall, Tuscaloosa Alabama and had a similar drainage area as the Bama Belle full-scale site (0.9 ac), but with slightly different land uses. Figure 58 shows the multiple comparisons of the TSS influent concentrations for the full-scale and the SBIR II tests, and the regional Alabama data from the NSQD database as well as the EPA Rain Zone 3 of NSQD (which also includes Alabama). NSQD data for Alabama was included information from Huntsville, Jefferson County, and the City of Mobile. Rain Zone 3 consists of the south eastern states of U.S. including: Alabama, Georgia, Florida, South Carolina, and the east half of Mississippi. Land use categories in the NSQD were mostly represented by commercial, residential, institutional, and freeway locations. Figure 58 is intended to illustrate the general TSS differences in these data subsets. The detailed analyses are included in Appendix E.

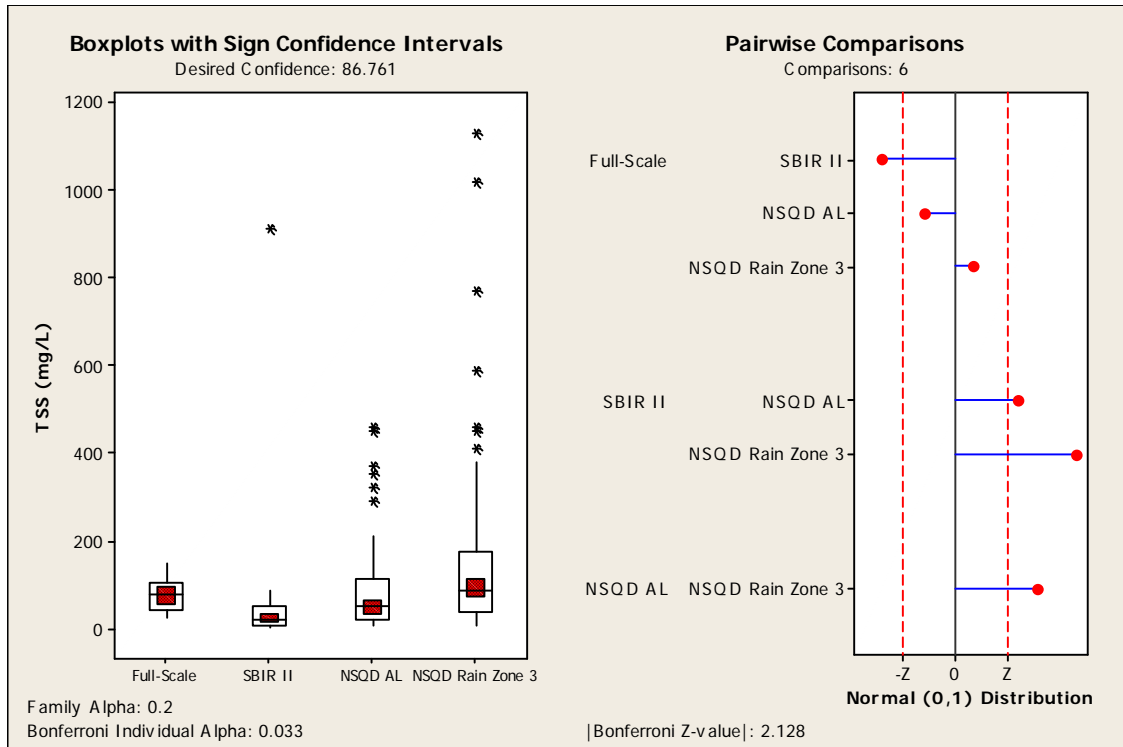

Figure 58. Multiple Comparison Plots for TSS

The multiple comparison results in Figure 58 show that the TSS concentration of the full-scale site was similar to the NSQD Alabama as well as the NSQD Rain Zone 3 data, but the SBIR II pilot-scale data was shown to be significantly different from all of the other data sets (having lower concentrations). As noted, the full-scale and the SBIR II sampling locations had similar areas (about 0.9 ac), but the Bama Belle site was mostly asphalt parking with a small landscaped area, while the City Hall SBIR II site was mostly a large roof area, a concrete parking deck, and an asphalt parking area. The large roof area likely resulted in reduced concentrations of some of the stormwater constituents compared to the larger surface parking area at the Bama Belle site. Figure 59 shows the rain depths during the monitoring at the full-scale, SBIR II, NSQD Alabama, and NSQA Rain Zone 3 locations, indicating only that the SBIR II rains were significantly different from the NSQD Rain Zone 3 rains.

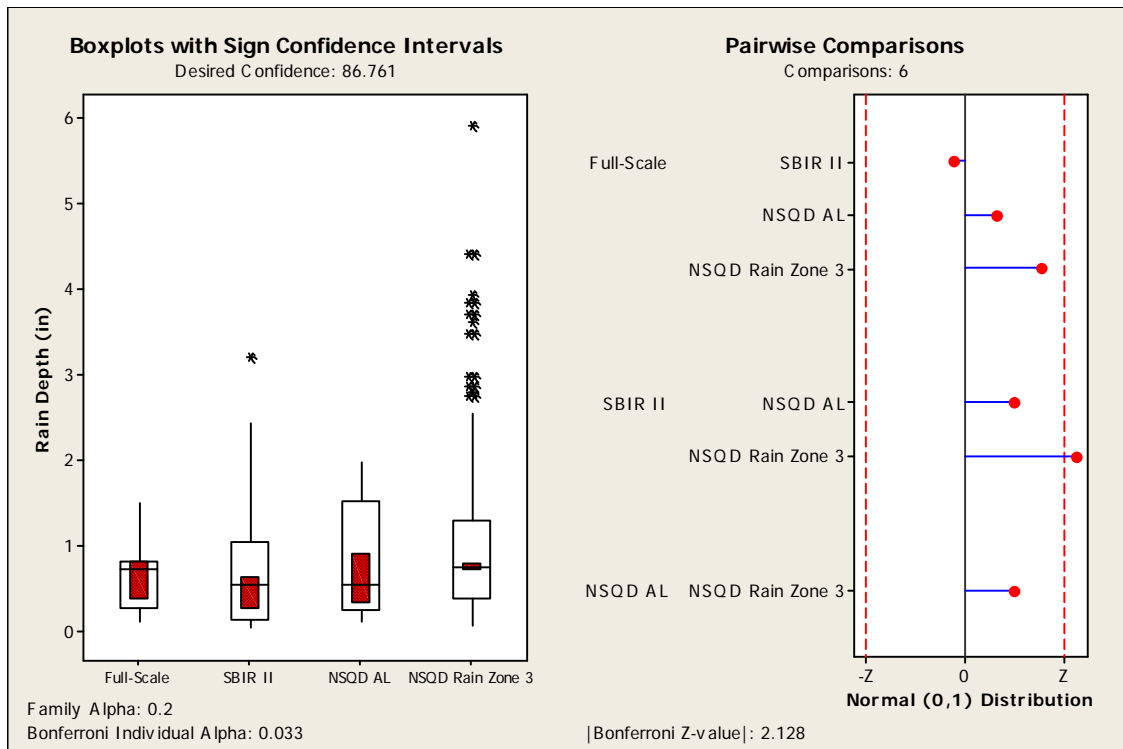

Figure 59. Multiple Comparison Plots for Rain Depth

Maestre and Pitt (2006) concluded that land use has a significant effect on pollutant characteristics. An improved proposed protocol needs to consider the difference in land use and stormwater characteristics, rather than the state political jurisdictions alone. It is also important to analyze site characteristic and identify local problems that are to be addressed with the treatment system. The proposed protocol also recommends the collection of samples prior to the selection of the test site in order to compare the site conditions to the monitoring objectives.

4.7 Minimum Storm Event Criteria Analysis

The first step in planning a sampling or testing plan is to prepare the experimental design, which includes determining the number of samples needed. Sample size influences the quality and accuracy of the analysis. Most manufacturers are only interested in collecting the fewest

number of samples necessary to document performance in order to minimize expenses associated with sampling and for the laboratory analyses. However, an inadequate sampling effort diminishes the usefulness of the results. Sampling theory provides a framework for the determination of sample size for different data quality objectives. The objective of this component in an evaluation protocol is to ensure that there are sufficient data to determine if a statistically significant difference exists between influent (untreated) and effluent (treated) pollutant concentrations, at a reasonable treatment rate. Fewer data are needed to detect a statistically significant difference if the influent and effluent concentrations differ by a large amount than if they are close. In order to accomplish this critical research objective, the samples also need to be taken in such a manner to ensure that they represent the sample flow. Influent samples need to be taken from the direct runoff before, or as it enters the treatment device, and the effluent samples need to be taken after passing through the device, including any bypass flows. Most commonly used statistical approaches used in experimental design calculations are based on comparing population means, and therefore assume that the data are normally distributed. Methods used to calculate the per group sample size require: 1) expected difference between the two population means, 2) within group standard deviation, 3) alpha (confidence) level, and 4) beta (power) level.

4.7.1 *Burton and Pitt Formula*

The following is a method to calculate needed sample size that was presented by Burton and Pitt (2001). The following equation can be used to estimate the needed number of samples for a one-sided test (assuming that the influent is greater than the effluent, for example) paired sample design (for two sided test, when the direction of the difference is not known, replace $Z_{1-\alpha}$ by $Z_{1-\alpha/2}$ and $Z_{1-\beta}$ by $Z_{1-\beta/2}$):

$$n = \frac{2(Z_{1-\alpha} + Z_{1-\beta})^2 \sigma^2}{(\mu_1 - \mu_2)^2}$$

where α = false positive rate ($1-\alpha$ is the degree of confidence. A value of α of 0.05 is usually considered statistically significant, corresponding to a $1-\alpha$ degree of confidence of 0.95, or 95%)

β = false negative rate ($1-\beta$ is the power. If used, a value of β of 0.2 is common, but it is frequently ignored, corresponding to a β of 0.5.)

$Z_{1-\alpha}$ = Z score (associated with area under normal curve) corresponding to $1-\alpha$

$Z_{1-\beta}$ = Z score corresponding to $1-\beta$ value

μ_1 = mean of data set one

μ_2 = mean of data set two

σ = standard deviation (same for both data sets, same units as μ . Both data sets are also assumed to be normally distributed.)

For small sample sizes, percentiles of the normal distribution are replaced by the percentiles of the t-distribution. In that case, the equation should be solved iteratively because the t-distribution depends on sample sizes. It is easily shown that if the sample size becomes larger, the t-distribution with n degree of freedom converges in distribution to the standard normal distribution. The below theorem describes the proof:

$$\lim_{n \rightarrow \infty} \left(1 + \frac{a}{n}\right)^n = e^a$$

Taking $a = t^2$

$$\lim_{n \rightarrow \infty} \left(1 + \frac{t^2}{n}\right)^n = e^{t^2}$$

$$\left(1 + \frac{t^2}{n}\right)^{-\frac{n+1}{2}} = \left[\left(1 + \frac{t^2}{n}\right)^n\right]^{-\frac{1}{2}} \left(1 + \frac{t^2}{n}\right)^{-\frac{1}{2}}$$

$$\lim_{n \rightarrow \infty} \left(1 + \frac{t^2}{n}\right)^{-\frac{n+1}{2}} = \lim_{n \rightarrow \infty} \left[\left(1 + \frac{t^2}{n}\right)^n\right]^{-\frac{1}{2}} \lim_{n \rightarrow \infty} \left(1 + \frac{t^2}{n}\right)^{-\frac{1}{2}} = e^{-t^2/2}$$

that,

$$\lim_{n \rightarrow \infty} \frac{\Gamma\left(\frac{n+1}{2}\right)}{\sqrt{\pi n} \Gamma\left(\frac{n}{2}\right)} = \frac{1}{\sqrt{2\pi}}$$

then,

$$\frac{1}{\sqrt{2\pi}} e^{-t^2/2} \sim N(0,1)$$

4.7.2 Paired Sample Formula

In the case of paired samples, the equation for the total number of pairs needed is the same as for the above Burton and Pitt example, except that the factor of 2 is dropped:

$$n = \frac{(Z_{1-\alpha} + Z_{1-\beta})^2 \sigma^2}{(\mu_1 - \mu_2)^2}$$

where σ^2 is now the variance of the difference in the paired observations. It is clear that the paired studies can reduce the required sample size by the factor of 2, if the pairing is effective. If the pairing is ineffective, however; the variance of the difference in the paired observations will be equalized to the number required for independent observations, then the total sample size will be equal to the Burton and Pitt formula.

4.7.3 *Different Variations Formula*

In both of the above cases, it is assumed that the variances in the two sample groups being compared are equal. However, for most effective stormwater controls during typical storm conditions, the effluent concentrations usually have smaller variances compared to the influent concentrations, as the controls more effectively reduce the high concentrations. In contrast, under some controlled experimental conditions, variations in the influent concentrations may be smaller than for the effluent concentrations. The following equation calculates the sample size for testing differences in means when the variations in the two groups are unequal:

$$n = \frac{(Z_{1-\alpha} + Z_{1-\beta})^2 (\sigma_1^2 + \sigma_2^2)}{(\mu_1 - \mu_2)^2}$$

where σ_1^2 and σ_2^2 are the variances in group 1 and 2 (the variances in the influent and effluent concentrations, respectively). There may be situations when different numbers of samples are collected for the influent and effluent samples. For instance, an investigator may collect initial influent samples before collecting complete sets of influent and effluent samples. These initial sample data can also be included by specifying the ratio of n_2 to n_1 , and express $\lambda = n_2 / n_1$ or $n_2 = \lambda n_1$ (however, this data would no longer be a paired analysis and would not have those benefits):

$$n = \frac{(Z_{1-\alpha} + Z_{1-\beta})^2 (\sigma_1^2 + \sigma_2^2 / \lambda)}{(\mu_1 - \mu_2)^2}$$

4.7.4 *Non-Parametric Sample Size Approach*

The above methods all assume that the data are normally distributed. However, that would be unusual for most stormwater monitoring data, with log-normal distributions being much more likely. If the samples are not normally distributed, a non-parametric approach can be

used to calculate the sample sizes for data having any type of distribution. Efron and Tibshirani (1994) introduced the bootstrapping computer-based method that enables one to assign a measure of accuracy to sample estimates. Varian (2005) also shows that the technique can be used with almost any data distributions using simple methods in Mathematica. The bootstrapping method is a powerful tool that can be programmed with many commercially available script language software including Mathematica and Matlab.

4.7.5 *UpFlow Project Example*

One other practical question when calculating the sample size for a stormwater control device evaluation is which constituents to use for calculating the sampling effort. It could be solids, metals, nutrients, or bacteria. Stormwater research shows that bacteria values are much more variable than the other constituents. Most of the primary protocols select SSC as the critical constituent and many regulatory programs use SSC control in their stormwater management programs. Table 32 summarizes the minimum number of samples required for the upflow projects based on SSC using the different calculation methods. The alpha level is 0.05 ($\alpha = 0.05$) and 80% power ($1 - \beta = 0.8$) is selected for the calculations.

Table 32. Required Sample Sizes for UpFlow Project

Parameters		Burton and Pitt	Paired Sample	Different Variance
SSC (Lab)	SBIR I	4	1	1
	SBIR II	8	5	5
	Penn State	7	4	4
	Full-Scale	12	7	9
SSC (Field)	SBIR II	76	79	82
	Full-Scale	7	3	4
Turbidity (Field)	SBIR II	88	81	87
	Full-Scale	12	8	9
E-Coli (Field)	SBIR II	67	19	65
	Full-Scale	78	45	77

Table 32 shows the calculated sample numbers for the different constituents and different sources of variability data. The field SSC concentrations had much larger variations compared to the laboratory SSC values from the SBIR II tests. In contrast, variations of SSC concentrations were much smaller for the field measurements when compared with the laboratory full-scale tests. As stated above, *E. coli* values were highly variable compared with any other constituents, requiring more samples than for most of the other scenarios.

4.8 Minimum Rain Depth and Storm Duration Criteria

The minimum rain depth, the rain duration, and the runoff volume may be related to each other, as small rains usually have shorter durations and smaller runoff volume. Longer rains, in contrast, usually have larger rain amounts which generates larger amounts of runoff. The key objective of these criteria is to ensure that sufficient rain depth and duration occurs to produce a sufficient and representative amount of runoff in the test drainage area. Figure 60 plots the rain depth (inches) vs. runoff volume (gallons) measured during the Bama Belle monitoring tests and the corresponding runoff amounts calculated by WinSLAMM.

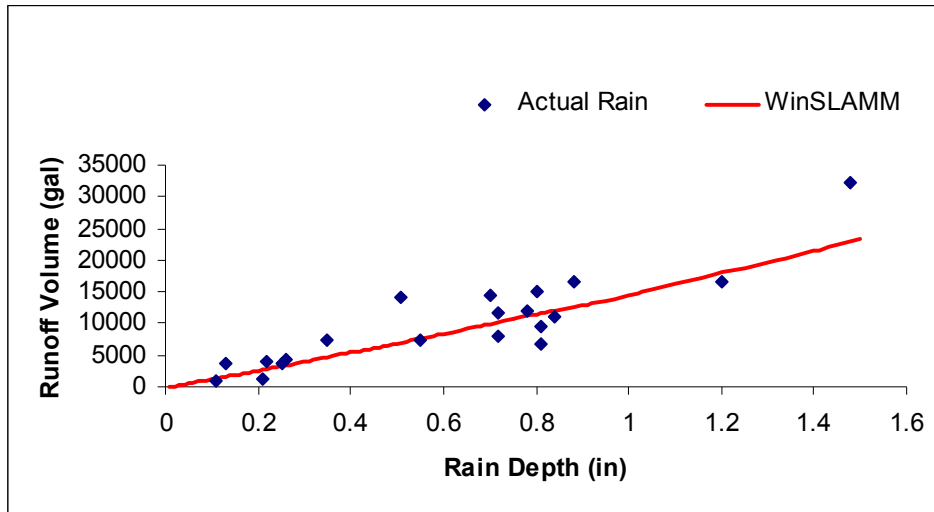

Figure 60. Runoff Volume vs. Rain Depth for Actual and Simulated Data

It is seen that WinSLAMM accurately represents the actual event data, although the actual runoff data was more variable than the modeled data. As noted in the methodology discussion, the rain data was measured using a tipping bucket rain gauge (partially blocked by nearby trees) and the runoff volume was measured by the area velocity sensor in the effluent pipe. A locally calibrated rainfall-runoff model can therefore be a useful tool when predicting runoff conditions for potential study areas. Figure 61 shows a 3D plot of the relationships between the measured runoff volume, the precipitation depth, and the rain duration for the monitored period.

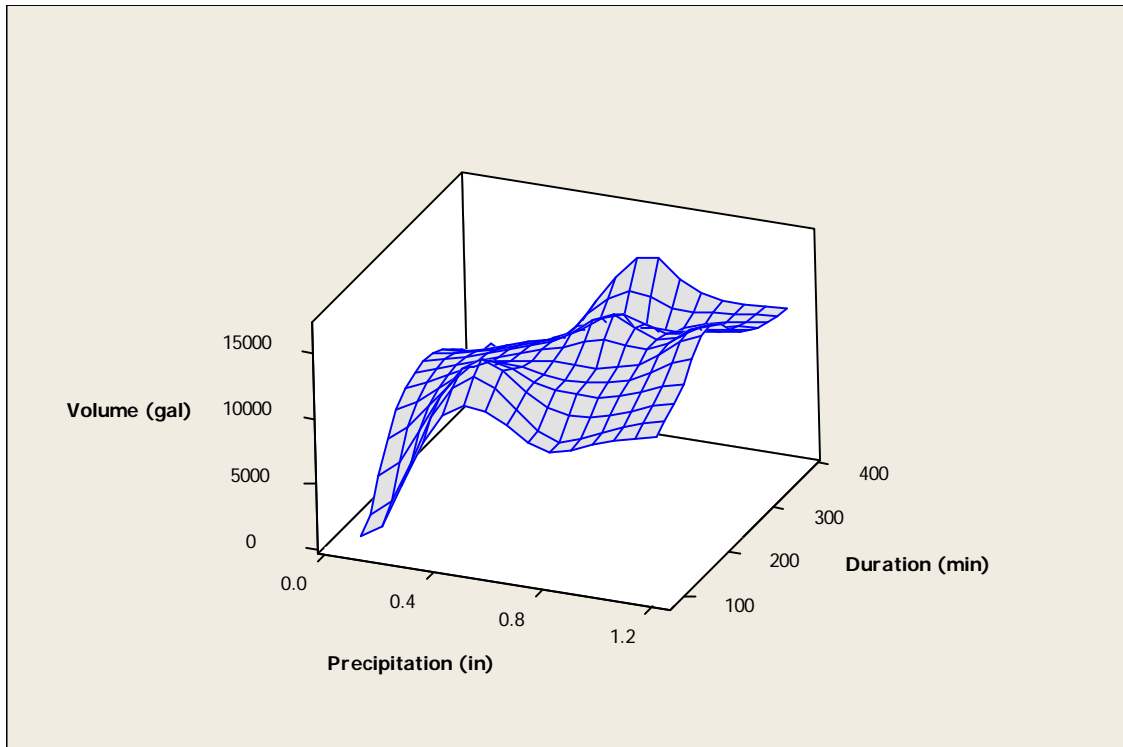

Figure 61. 3D Plots for Volume, Precipitation, and Duration

Figure 61 indicates that the runoff volume increased as the precipitation increased, as expected, but that the rain duration had a much smaller effect on the runoff volume. Minimum rain depth and storm duration criteria could be examined using a stormwater model before the site is selected for monitoring. The minimum number of subsamples per event is also critical and is related to these parameters, as discussed in the following section.

4.9 Requirements for the Minimum Number of Subsamples per Event

The minimum numbers of subsamples to be collected during each event is another component of all protocols. In most cases, a single flow-weighted composite sample is analyzed for the influent and for the effluent for each event. Therefore, the objective of this criterion is to

ensure that sufficient subsamples are obtained to adequately represent the characteristics of the complete event. Mathematical calculations similar to the experimental design calculations previously described in Section 4.7 can be used to determine the required number of subsamples per event. During the Bama Belle full-scale tests, the automatic samplers were programmed to collect samples as a function of the amount of flow that had passed. Based on the expected rainfall amount (and corresponding runoff volume), the sampling frequency and the total number of subsamples were vary for different expected rainfall depths. Figure 62 is the storm data from the monitored July 16, 2010 rain event. This figure shows the water level, outlet level, flow rate, and rain intensity. Figure 63, also from the July 16, 2010 event, shows the high resolution influent and effluent turbidity data from the YSI 6000 water quality monitoring sondes, along with the times of the automatic subsampling.

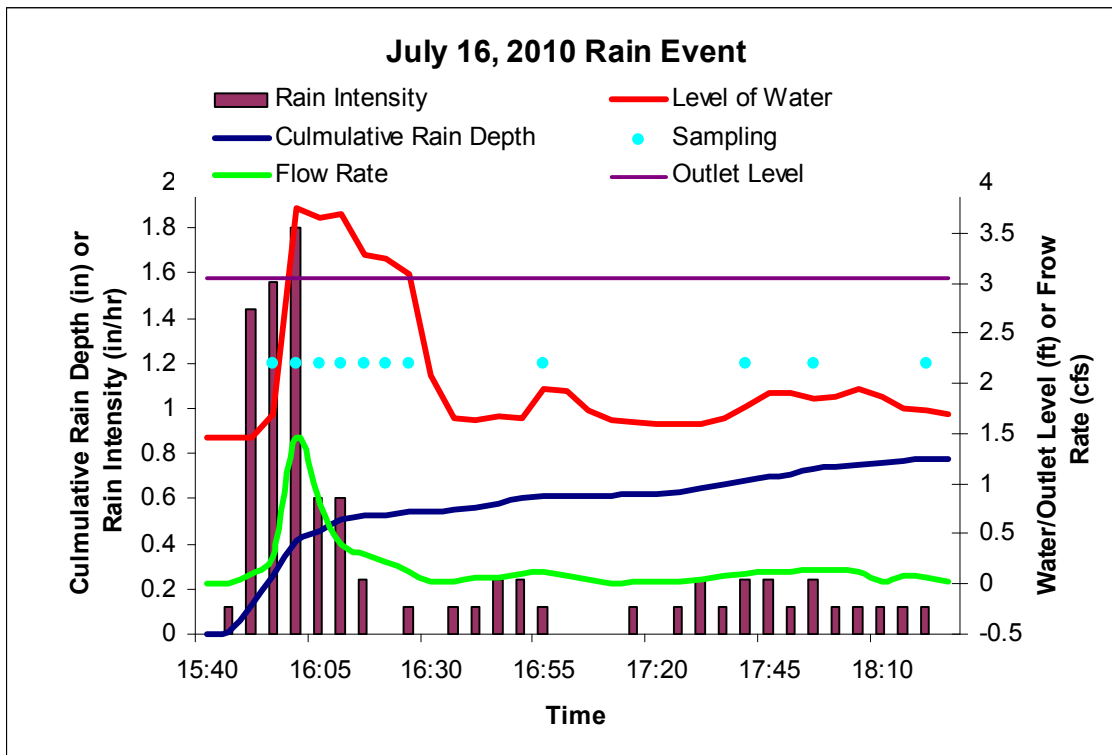

Figure 62. July 16, 2010 Rain Event Graph

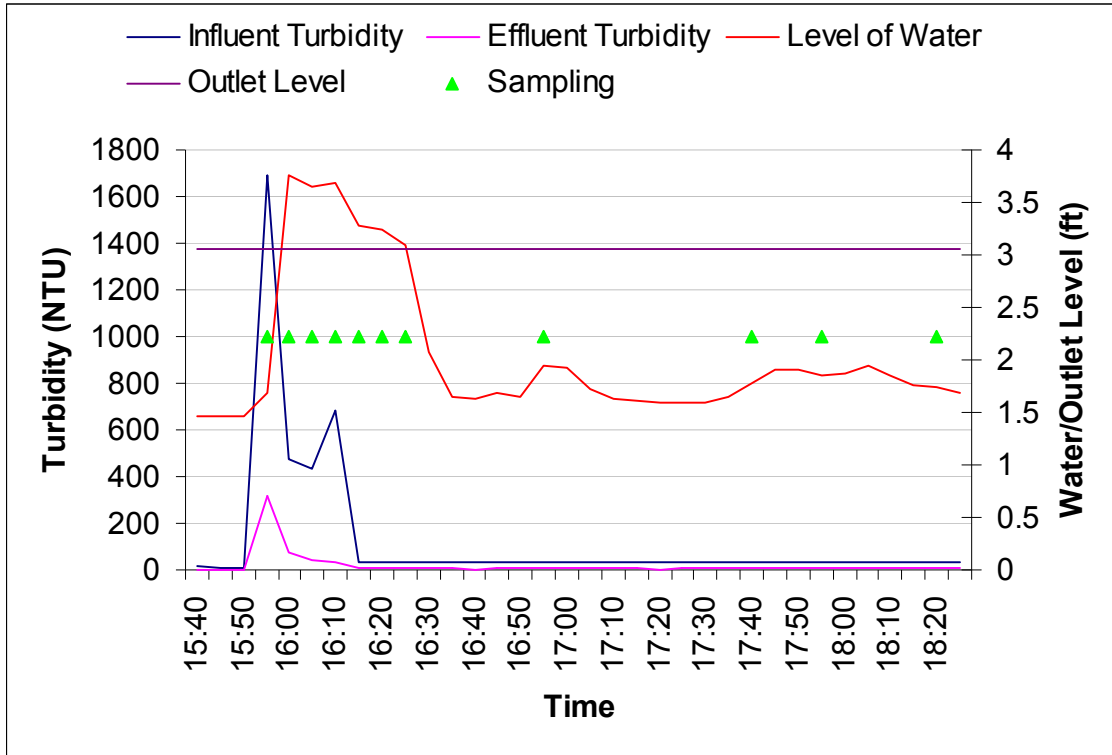

Figure 63. July 16, 2010 Storm Turbidity Data and Subsampling Times

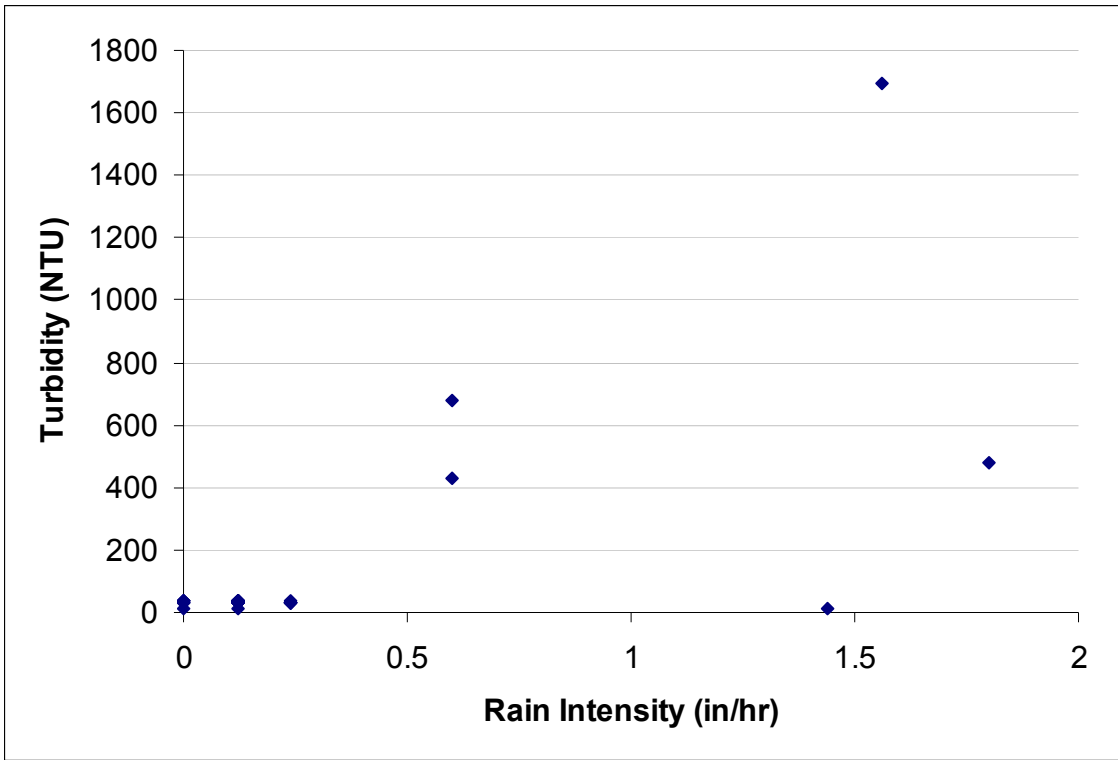

Figure 64. July 16, 2010 Storm Turbidity vs. Rain Intensity Graph

These data indicated a large “first flash” effect (high turbidity at the beginning of an event, and lowered turbidity as the event progressed). It was also seen that some of the stormwater was bypassing the filter unit at the beginning of the event. The sampling point notations indicate that about half of the subsamples were collected during the high intensity rain period (corresponding to the high runoff flow rates). The subsamples were collected on a flow (volume) weighted basis, with the samplers programmed to collect a subsample for every set volume of stormwater treated. Figure 64 also shows the relationship between turbidity and rain intensity. As the rain intensity increases, the rain energy available to erode and transport the soils also increases, resulting in higher turbidity levels. Influent turbidity was as high as about 1700 NTU when the rain intensity measured approximately 1.6 inch per hour. The flow-weighted

composite influent turbidity was about 56 NTU and the flow-weighted composite effluent turbidity was about 8 NTU for this event. After about 30 minutes since the beginning of the event, the influent turbidity was stabilized at a very low and remained at a constant level for the remainder of the event. During the high flow bypassing periods, the turbidity levels were also high. Figure 65 shows the statistical comparison analyses for the single composite samples and the high resolution turbidity values. The individual composite values are much less than the overall averaged discrete values, as expected. Detailed analyses are presented in Appendix F.

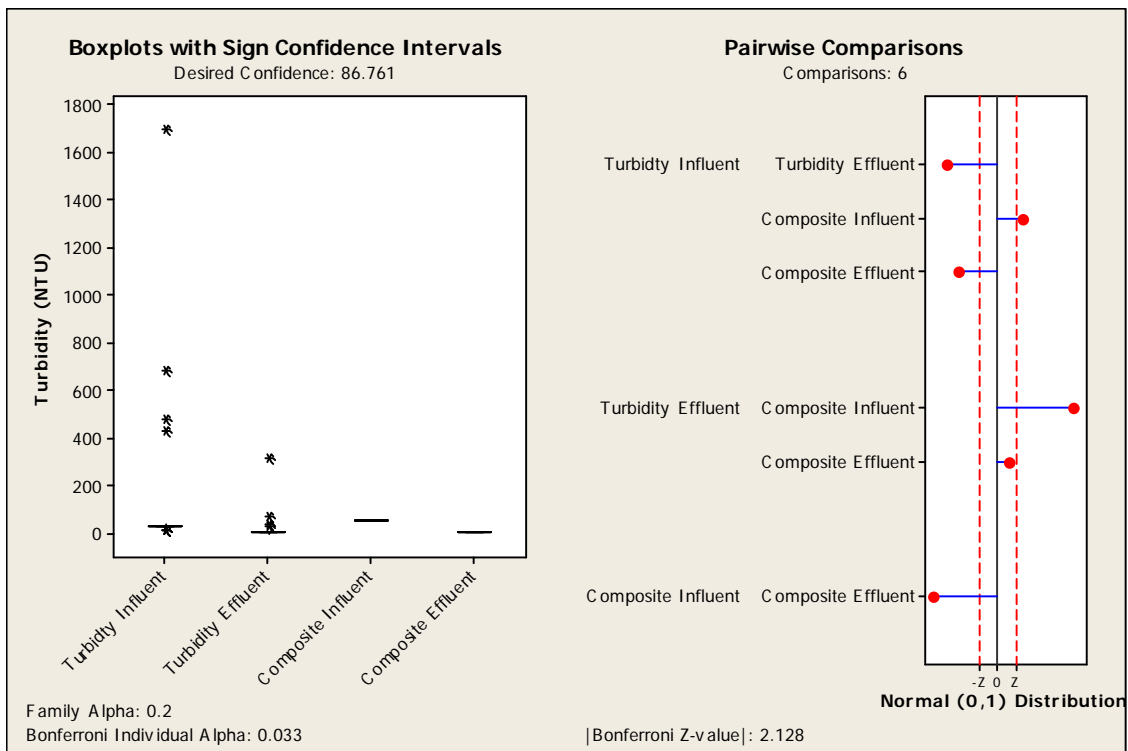

Figure 65. Multiple Comparisons for the Composite Data and Data from Sondes

The flow based composite sampling method best represents the mass discharged from the device, which is usually the most important factor when evaluating stormwater treatment devices.

4.10 Minimum Time Between Event Criterion Analysis

The minimum antecedent time between each monitored storm event is a common criterion in the protocols. A six hour minimum time criterion is most common and has been frequently used during urban stormwater research as that time period is usually sufficient to allow obvious separations between adjacent storm hydrographs and it also allows the impervious surfaces to dry. Figure 66 and Table 33 summarize the events for November 2, 2010 and November 3, 2010. These two events had an antecedent time of about 24 hrs between them and they had similar rain depths. Unfortunately, there were no rain events during the monitoring period that had very short antecedent periods for comparison.

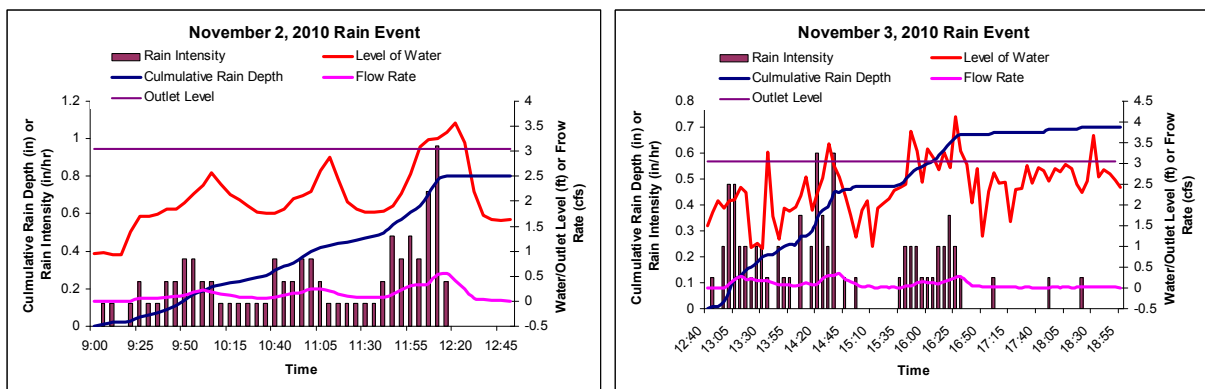

Figure 66. Storm Event for November 2 and 3, 2010

Table 33. Storm Event Summary for November 2 and 3, 2010

	November 2, 2010	November 3, 2010
Storm Start/End	9:00am~12:50pm	12:40pm~6:55pm
Precipitation (inches)	0.8	0.7
Average Rain Intensity (in/hr)	0.20	0.11
Peak Rain Intensity (in/hr)	0.96	0.60
TSS (mg/L)	72.0	87.0
Turbidity (NTU)	15.4	7.6
<i>E. coli</i> (MPN/100 mL)	3,240	46,110

Most assume that events with short antecedent periods accumulate little contaminants and therefore have lower concentrations. The minimum antecedent time criteria are intended to keep pollutant concentrations at moderate to high levels. These event data show very little difference in pollutant levels; the TSS and *E. coli* levels were actually larger during the second event that had a much shorter antecedent dry period. Also, in many cases, the six hour period may not be accurate to ensure drying of the surfaces due to the variations in slope, material of the surfaces, temperature, moisture, and roughness coefficient of the surface, etc. At the Bama Belle site, the 0.9 ac drainage area was mostly impervious, with a pervious fringe area. The site had a runoff lag time (from the centroid of the rain mass to the centroid of the runoff volume) of about 30 minutes.

The proposed protocol will recommend modifying the six hours criteria based on site conditions to ensure that representative events are all sampled, as long as the event hydrographs can be cleanly separated. The continuous water quality monitoring sonde also indicated that the turbidity of the runoff was highly correlated to the intensity of the rain. These data can also be used to separate the storms into different monitoring periods.

4.11 Overall Summary Tables of Performance

Tables 34 through 41 summarize the overall performances of the upflow filter for the SBIR II (pilot-scale test) and the full-scale under both controlled and actual storm events for the different particle sizes.

Table 34. Overall Performance Summary for <0.45 μm (TDS)

Flow rate per square feet	p-value that influent equals effluent	regression equation (or Y = constant)	COV	p-value for intercept	p-value for slope	overall p-value for equation	adjusted R ²
Full 2.8 gpm/ft ²	0.01	Y = 0.67X	n/a*	no term	<0.01	<0.01	0.66
SBIR II 3.3 gpm/ft ²	0.28	Y = X**	n/a	no term	no term	Insufficient data	n/a***
Full 8.3 gpm/ft ²	0.01	Y = 104	0.07	no term	no term	constant	n/a
SBIR II 10 gpm/ft ²	0.07	Y = 84	0.14	no term	no term	constant	n/a
Full 16.7 gpm/ft ²	0.01	Y = 78	0.04	no term	no term	constant	n/a
SBIR II 18 gpm/ft ²	0.39	Y = X	n/a	no term	no term	Insufficient data	n/a
Full actual	<0.01	Y = 65	0.46	no term	no term	constant	n/a
SBIR II actual	0.09	Y = 38	2.0	no term	no term	constant	n/a

* the COV value is only when the effluent concentration is a constant (no significant intercept or slope terms)

** the removal was not found to be significant (not enough samples to detect a difference), so the effluent concentrations are assumed to be equal to the influent concentrations. Equations are shown when p values are 0.1 or smaller.

*** R² values are not available when the effluent is a constant (no slope terms)

Table 34 summarizes the overall performance relationships for TDS. It indicates that the pilot-scale tests did not show significant differences between influent and effluent TDS concentrations ($p > 0.05$), while the full-scale test results did show significant reduction of TDS. The removal relationships for both tests were similar for “medium” and “high” controlled flow conditions and under actual storm conditions, with the effluent concentrations determined to be constants.

Table 35. Overall Performance Summary for 0.45 to 3 μm

Flow rate per square feet	p-value that influent equal effluent	regression equation (or $Y = \text{constant}$)	COV	p-value for intercept	p-value for slope	overall p-value for equation	adjusted R^2
Full 2.8 gpm/ft ²	0.04	$Y = 0.23X$	n/a	no term	<0.01	0.01	0.64
SBIR II 3.3 gpm/ft ²	0.19	$Y = X$	n/a	no term	no term	Insufficient data	n/a
Full 8.3 gpm/ft ²	0.07	$Y = 0.18X + 2.1$	n/a	<0.01	<0.01	<0.01	0.99
SBIR II 10 gpm/ft ²	0.28	$Y = X$	n/a	no term	no term	Insufficient data	n/a
Full 16.7 gpm/ft ²	0.12	$Y = 8.2$	0.73	no term	no term	constant	n/a
SBIR II 18 gpm/ft ²	0.39	$Y = X$	n/a	no term	no term	Insufficient data	n/a
Full actual	0.09	$Y = 0.55X$	n/a	no term	<0.01	<0.01	0.68
SBIR II actual	0.06	$Y = 1.6$	1.7	no term	no term	constant	n/a

Table 35 shows the summary removal relationships for the particle sizes from 0.45 to 3 μm . The pilot-scale tests did not indicate significant influent and effluent differences in concentrations for most of the controlled flow tests, but both test series indicated significant

differences ($p < 0.1$) during actual storm monitoring. The removal relationships for the pilot-scale and the full-scale tests were not similar.

Table 36. Overall Performance Summary for 3 to 12 μm

Flow rate per square feet	p-value that influent equal effluent	regression equation (or $Y = \text{constant}$)	COV	p-value for intercept	p-value for slope	overall p-value for equation	adjusted R^2
Full 2.8 gpm/ft ²	0.07	$Y = 0.25X$	n/a	no term	<0.01	0.01	0.63
SBIR II 3.3 gpm/ft ²	0.19	$Y = X$	n/a	no term	no term	Insufficient data	n/a
Full 8.3 gpm/ft ²	0.07	$Y = 0.29X + 5.2$	n/a	<0.01	<0.01	<0.01	0.99
SBIR II 10 gpm/ft ²	0.39	$Y = X$	n/a	no term	no term	Insufficient data	n/a
Full 16.7 gpm/ft ²	0.19	$Y = X$	n/a	no term	no term	Insufficient data	n/a
SBIR II 18 gpm/ft ²	0.50	$Y = X$	n/a	no term	no term	Insufficient data	n/a
Full actual	<0.01	$Y = 0.42X$	n/a	no term	<0.01	<0.01	0.70
SBIR II actual	0.07	$Y = 0.10X + 2.3$	n/a	<0.01	<0.01	<0.01	0.62

Table 36 shows the performance relationships for the 3 to 12 μm particle sizes. There were no statistically significant differences in the influent and effluent concentrations for controlled pilot-scale tests, while the full-scale controlled tests were marginally significant. Both of the pilot-scale and the full-scale tests during actual rains did indicate significant reductions. The actual event regression equations were different for the two different scales of the tests.

Table 37. Overall Performance Summary for 12 to 30 μm

Flow rate per square feet	p-value that influent equal effluent	regression equation (or $Y = \text{constant}$)	COV	p-value for intercept	p-value for slope	overall p-value for equation	adjusted R^2
Full 2.8 gpm/ft ²	0.02	$Y = 0.12X$	n/a	no term	<0.01	0.01	0.63
SBIR II 3.3 gpm/ft ²	0.07	$Y = 2.9$	0.55	no term	no term	constant	n/a
Full 8.3 gpm/ft ²	0.07	$Y = 0.26X$	n/a	no term	<0.01	<0.01	0.99
SBIR II 10 gpm/ft ²	0.39	$Y = X$	n/a	no term	no term	Insufficient data	n/a
Full 16.7 gpm/ft ²	0.07	$Y = 0.40X$	n/a	no term	<0.01	<0.01	0.66
SBIR II 18 gpm/ft ²	0.39	$Y = X$	n/a	no term	no term	Insufficient data	n/a
Full actual	<0.01	$Y = 0.38X$	n/a	no term	<0.01	<0.01	0.73
SBIR II actual	0.05	$Y = 0.13X + 2.7$	n/a	<0.01	<0.01	<0.01	0.93

Table 37 shows the performance relationships for 12 to 30 μm particulates. There were significant (or close to significant) reductions for all tests, except for the pilot-scale tests during the moderate and high flow rates.

Table 38. Overall Performance Summary for 30 to 60 μm

Flow rate per square feet	p-value that influent equal effluent	regression equation (or Y = constant)	COV	p-value for intercept	p-value for slope	overall p-value for equation	adjusted R ²
Full 2.8 gpm/ft ²	0.01	Y = 2.5	0.62	no term	no term	constant	n/a
SBIR II 3.3 gpm/ft ²	0.01	Y = 1.1	0.29	no term	no term	constant	n/a
Full 8.3 gpm/ft ²	0.06	Y = 0.22X	n/a	no term	<0.01	<0.01	0.99
SBIR II 10 gpm/ft ²	0.01	Y = 1.0	0.17	no term	no term	constant	n/a
Full 16.7 gpm/ft ²	0.12	Y = 14	0.85	no term	no term	constant	n/a
SBIR II 18 gpm/ft ²	0.01	Y = 0.022X+0.84	n/a	0.03	0.04	0.04	0.90
Full actual	<0.01	Y = 5.7	0.97	no term	no term	constant	n/a
SBIR II actual	0.01	Y = 0.31X	n/a	no term	<0.01	<0.01	0.84

Table 38 shows the overall performance characteristics for the 30 to 60 μm particulates. There were significant (or close to significant) differences for both the full-scale and the pilot-scale tests under both controlled and actual storm events. There were similar constant effluent concentrations for the “low” flow controlled tests.

Table 39. Overall Performance Summary for 60 to 120 μm

Flow rate per square feet	p-value that influent equal effluent	regression equation (or $Y = \text{constant}$)	COV	p-value for intercept	p-value for slope	overall p-value for equation	adjusted R^2
Full 2.8 gpm/ft ²	0.01	$Y = 0.48$	0.57	no term	no term	constant	n/a
SBIR II 3.3 gpm/ft ²	0.01	$Y = 0.54$	0.82	no term	no term	constant	n/a
Full 8.3 gpm/ft ²	0.04	$Y = 1.0$	0.42	no term	no term	constant	n/a
SBIR II 10 gpm/ft ²	0.01	$Y = 1.2$	1.28	no term	no term	constant	n/a
Full 16.7 gpm/ft ²	0.12	$Y = 2.0$	0.90	no term	no term	constant	n/a
SBIR II 18 gpm/ft ²	0.01	$Y = 0.31$	1.04	no term	no term	constant	n/a
Full actual	<0.01	$Y = 4.0$	1.02	no term	no term	constant	n/a
SBIR II actual	0.04	$Y = 0.45X$	n/a	no term	<0.01	<0.01	0.64

Table 39 summarizes the performance characteristics for 60 to 120 μm particulates. There were significant reductions in concentrations for most of the controlled and the actual tests, as the p-values were all less than 0.05, except for the full scale high rate tests which were close to significant at 0.12. There were similar removal performance results (similar constant effluent concentrations) for all of the controlled and actual rain observations.

Table 40. Overall Performance Summary for 120 to 250 μm

Flow rate per square feet	p-value that influent equal effluent	regression equation (or $Y = \text{constant}$)	COV	p-value for intercept	p-value for slope	overall p-value for equation	adjusted R^2
Full 2.8 gpm/ft ²	0.01	$Y = 0.078$	0.68	no term	no term	constant	n/a
SBIR II 3.3 gpm/ft ²	0.01	$Y = 0$	n/a	no term	no term	constant	n/a
Full 8.3 gpm/ft ²	0.01	$Y = 0.17$	0.78	no term	no term	constant	n/a
SBIR II 10 gpm/ft ²	0.19	$Y = X$	n/a	no term	no term	Insufficient data	n/a
Full 16.7 gpm/ft ²	0.01	$Y = 0.085$	0.64	no term	no term	constant	n/a
SBIR II 18 gpm/ft ²	0.01	$Y = 0$	n/a	no term	no term	constant	n/a
Full actual	<0.01	$Y = 0.067X$	n/a	no term	<0.01	<0.01	0.63
SBIR II actual	n/a	n/a	n/a	n/a	n/a	n/a	n/a

Table 40 shows the performance summary for 120 to 250 μm particulates. All of the full-scale and the pilot-scale tests demonstrated significant reductions of particulates. Regression and ANOVA analyses showed that the effluent concentrations were all close to zero, indicating almost complete removal of these particulates under a wide range of conditions. Few of these larger particles were collected in any of the effluent samples, and no particulates of this size were observed during the pilot-scale rain tests.

Table 41. Overall Performance Summary for >250 μm

Flow rate per square feet	p-value that influent equal effluent	regression equation (or Y = constant)	COV	p-value for intercept	p-value for slope	overall p-value for equation	adjusted R ²
Full 2.8 gpm/ft ²	0.01	Y = 0	n/a	no term	no term	constant	n/a
SBIR II 3.3 gpm/ft ²	0.01	Y = 0	n/a	no term	no term	constant	n/a
Full 8.3 gpm/ft ²	0.01	Y = 0	n/a	no term	no term	constant	n/a
SBIR II 10 gpm/ft ²	0.01	Y = 0	n/a	no term	no term	constant	n/a
Full 16.7 gpm/ft ²	0.01	Y = 0	n/a	no term	no term	constant	n/a
SBIR II 18 gpm/ft ²	0.01	Y = 0	n/a	no term	no term	constant	n/a
Full actual	<0.01	Y = 4.2	1.0	no term	no term	constant	n/a
SBIR II actual	n/a	n/a	n/a	n/a	n/a	n/a	n/a

Table 41 summarizes the performance relationships for the largest particles, those larger than 250 μm . All the p-value were less than 0.05 in all tests indicating significant reductions of influent concentrations. Most of the equation showed that Y=0 as it was rare to observe these large particles in the effluent samples. They were also not observed in the influent at the pilot-scale test location.

The overall performance summaries showed that there were similar performance observations for the full-scale and the pilot-scale test for the larger particulates, for both controlled and actual rains. Differences were more common for the smaller particles, especially for the medium and high flow rate tests.

Chapter 4 summarized the analytical results from different scales and test protocols for the upflow filtration device. Previous bench-scale and pilot-scale test data of the upflow filtration processes were compared to the results of the current full-scale tests. A series of post framework

questions were also discussed in this chapter. Chapter 5 summarizes the overall field performance results of the full-scale upflow filter for the controlled tests and the continuous monitoring tests conducted for actual storms.

CHAPTER 5

5: PERFORMANCE OF FULL-SCALE UPFLOW FILTER

The second objective of this research was “*Verify that the upflow filtration process is a suitable in-drain treatment technology for stormwater treatment under a wide range of site and hydraulic conditions.*” Performance tests of the full-scale upflow filter were compared to the observations obtained during laboratory and pilot-scale testing. These full-scale tests conducted at the Bama Belle site indicated a promising technology for the treatment of a variety of contaminants under varying flow rates. Especially noteworthy was its ability to significantly remove very small particulates. This chapter summarizes the field performance result of the full-scale upflow filter (Up-Flo[®] Filter) for the controlled tests as well as the continuous monitoring tests conducted during actual storm events. These detailed observations were compared to the different testing protocols in the following chapter.

5.1 Controlled Test Results

The controlled performance monitoring was conducted at the Riverwalk parking lot near the Bama Belle excursion boat in Tuscaloosa, Alabama, in late summer of 2009. The controlled flow test was conducted for the purpose of determining the hydraulic capacity and the pollutant

removal capability in a full-scale field installation under known flow rate and sediment concentration. Detailed descriptions of the test were described in Chapter 3.

The detailed analyses including probability plots, non-parametric analyses comparing significant difference in influent and effluent concentrations, ANOVA tests, and residual analyses are included in Appendix G.

5.1.1 *Sand Media 25 gpm Controlled Flow Test Results*

Sand media was used for the first controlled flow test at the “Low” flow rate condition (25 gpm, or 3 gpm/ft²). Figure 67 shows the simple line performance plots of this controlled test for different particle sizes from less than 0.45 μm to more than 1180 μm.

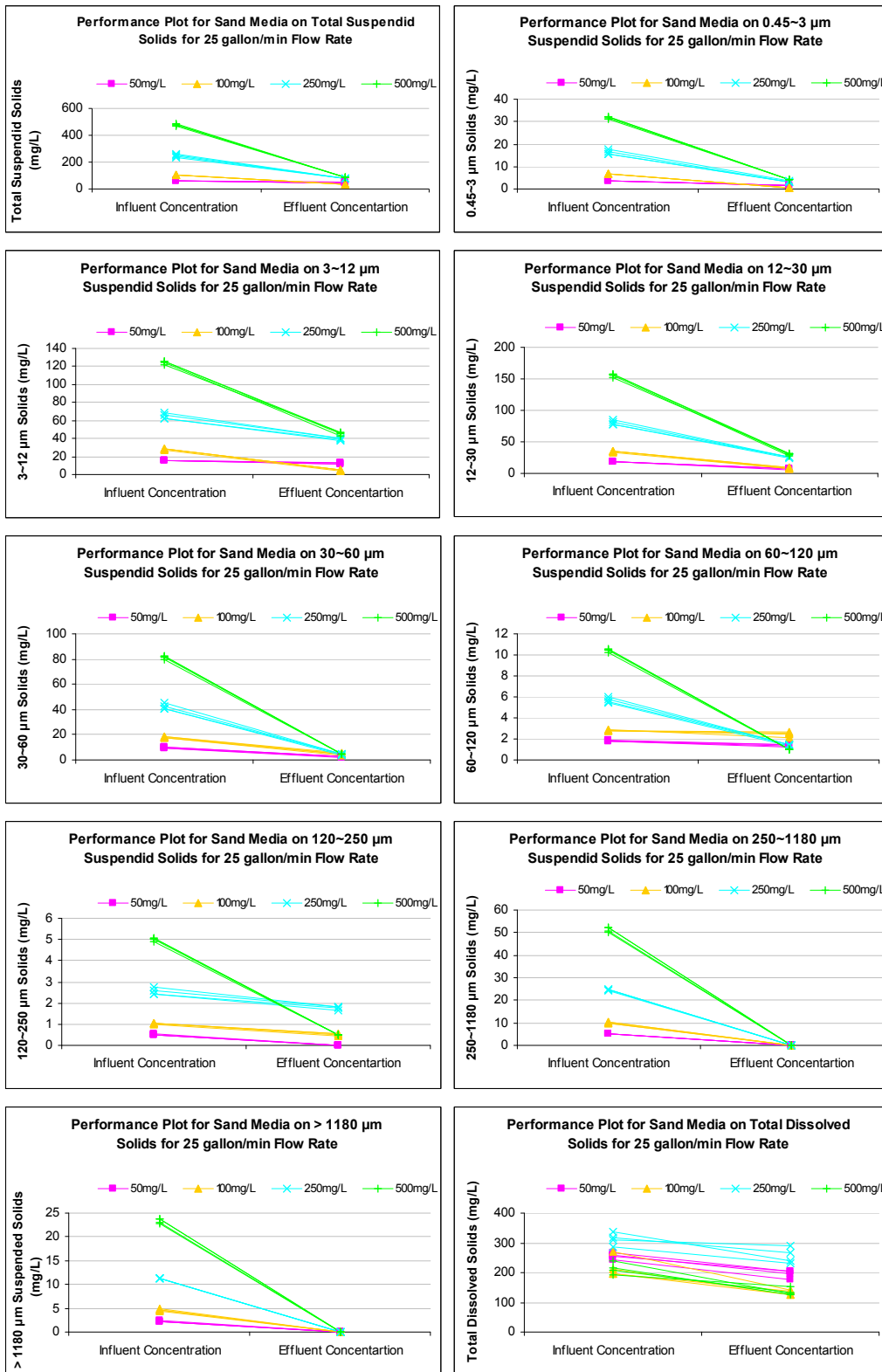

Figure 67. Sand Media 25 gpm Controlled Flow Test Results

5.1.2 *Sand Media 75 gpm Controlled Flow Test Results*

Similar results were obtained for the “Medium” flow rate (75 gpm, or 8 gpm/ft²). Figure 68 shows the line performance plots for this controlled test for different particle sizes. The line plots indicate almost 100% reductions for the particle sizes larger than 30 μm, with reduced treatment for the smaller particles.

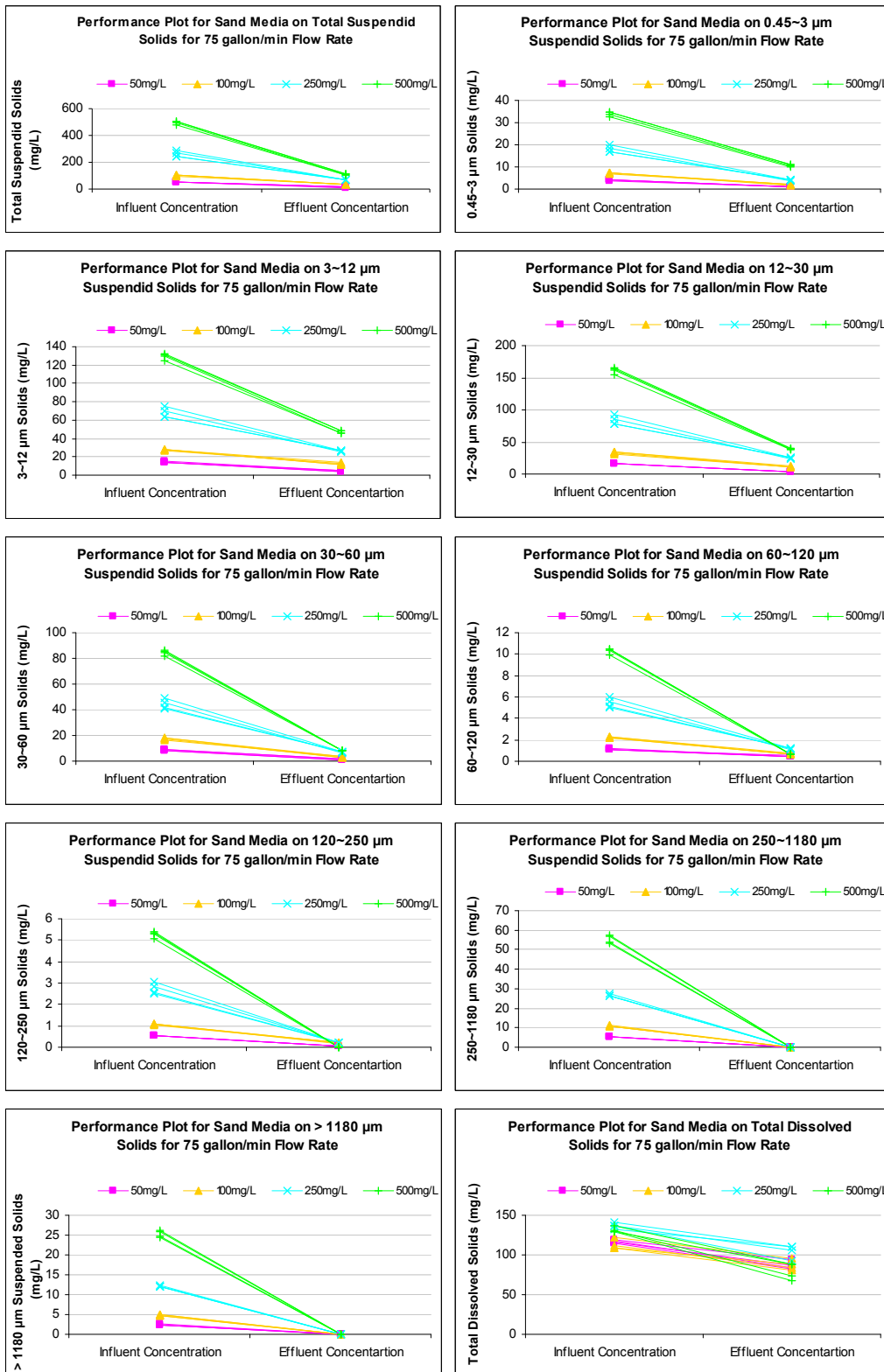

Figure 68. Sand Media 75 gpm Controlled Flow Test Results

5.1.3 *Sand Media 150 gpm Controlled Flow Test Results*

Figure 69 shows the performance plots for the controlled test for the “High” flow rate conditions (150 gpm, or 17 gpm/ft²). The line plots were similar to the above “Low” and “Medium” flow rate conditions: almost complete removal for the largest particles, and reduced performance for the smaller particles, as expected.

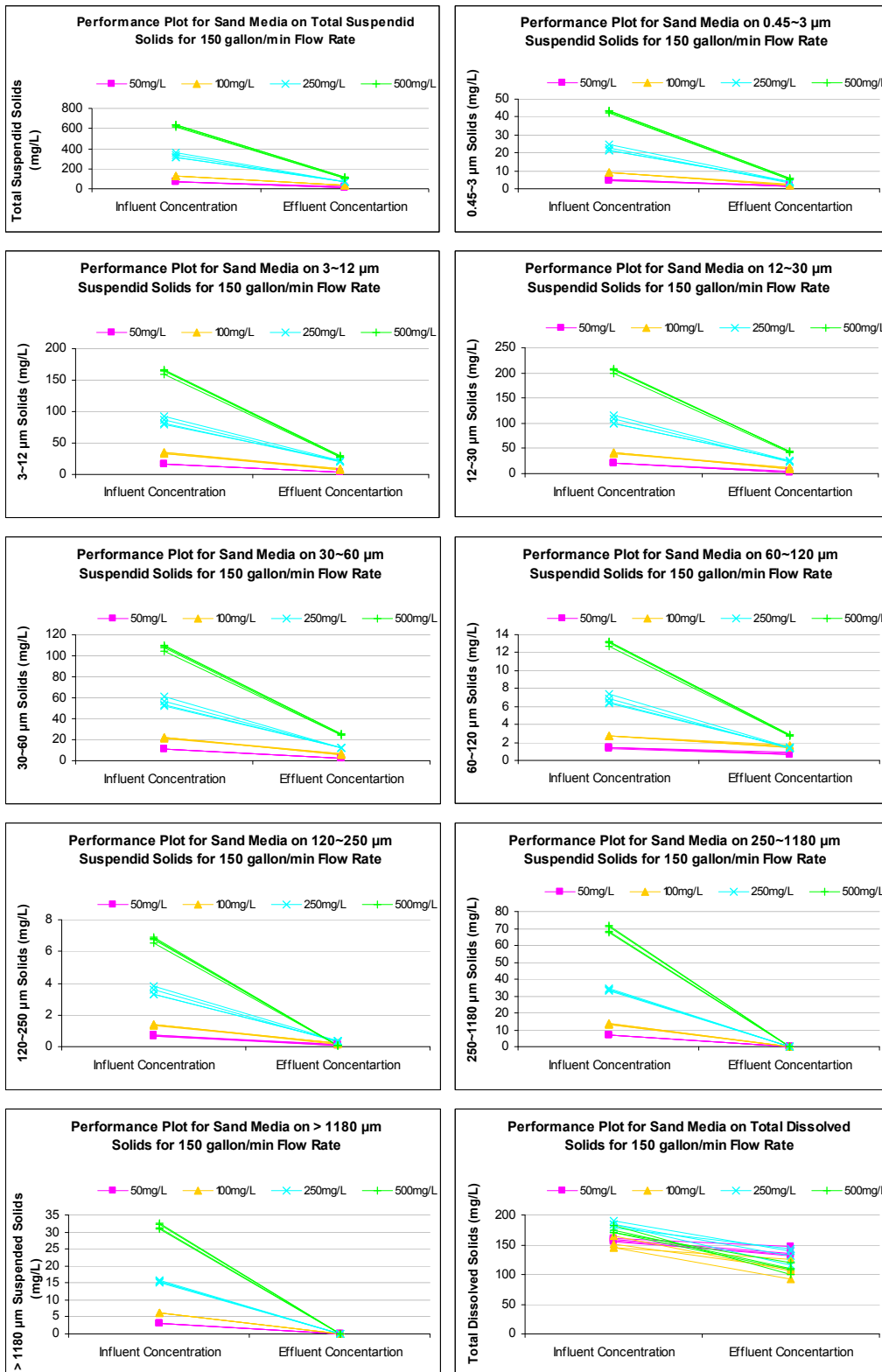

Figure 69. Sand Media 150 gpm Controlled Flow Test Results

5.1.4 *CPZ MixTM Media 25 gpm Controlled Flow Test Results*

Similar controlled tests were conducted using the CPZ media, a proprietary mixture of bone char activated carbon, peat moss, and manganese coated zeolite. Figure 70 shows the performance line plots for the “Low” flow rate conditions (25 gpm, or 3 gpm/ft²) for the different particle size ranges.

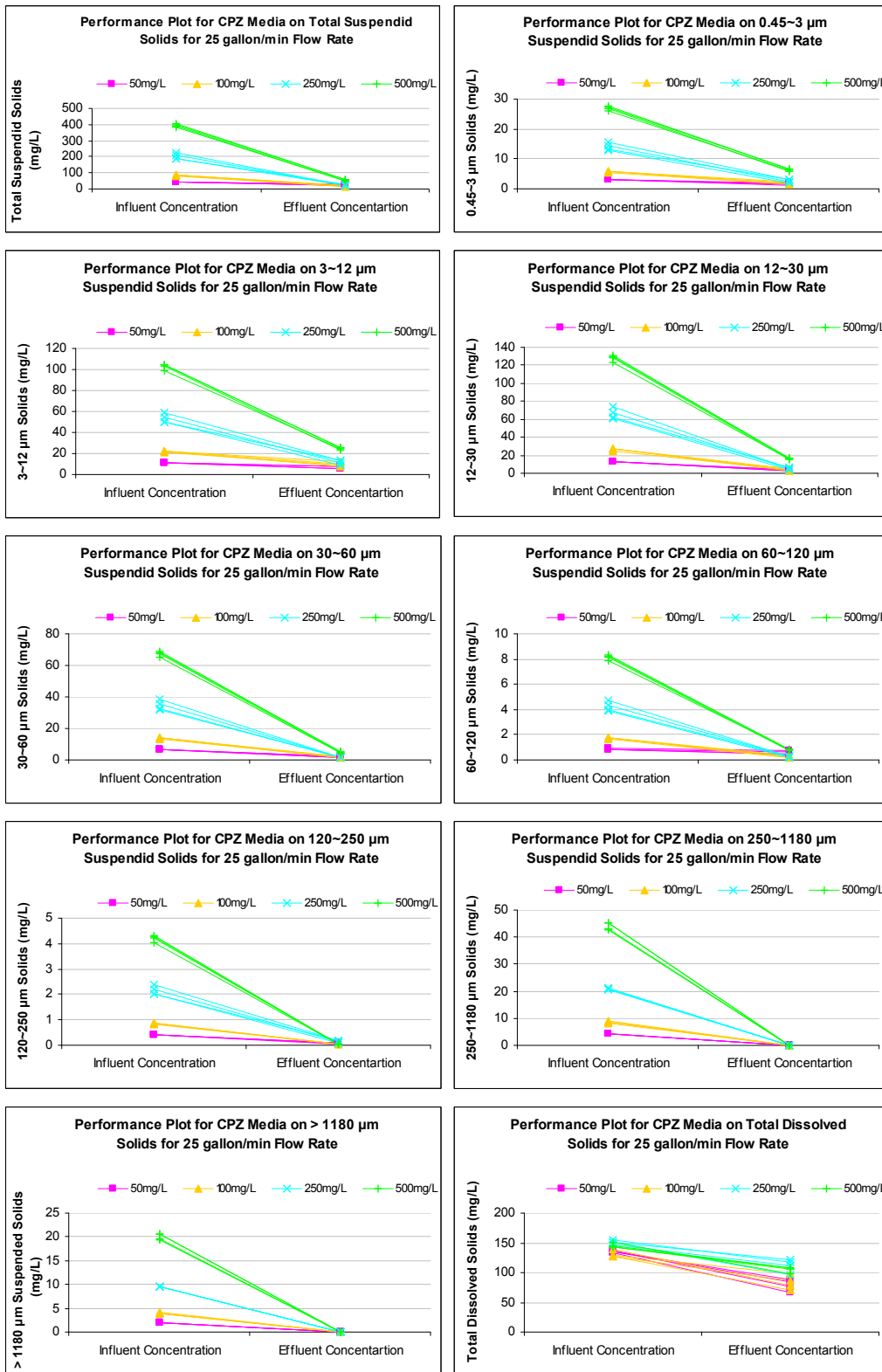

Figure 70. CPZ Mix™ Media 25 gpm Controlled Flow Test Results

5.1.5 *CPZ MixTM Media 75 gpm Controlled Flow Test Results*

Similar to the “Low” flow rate conditions, the “Medium” flow rate (75 gpm, or 8 gpm/ft²) was tested using the CPZ media. Figure 71 shows the line performance plots for this controlled test for the different particle sizes. Results were similar to the sand media tests in that higher reductions were seen for the larger particles with somewhat smaller reductions for the smaller particles.

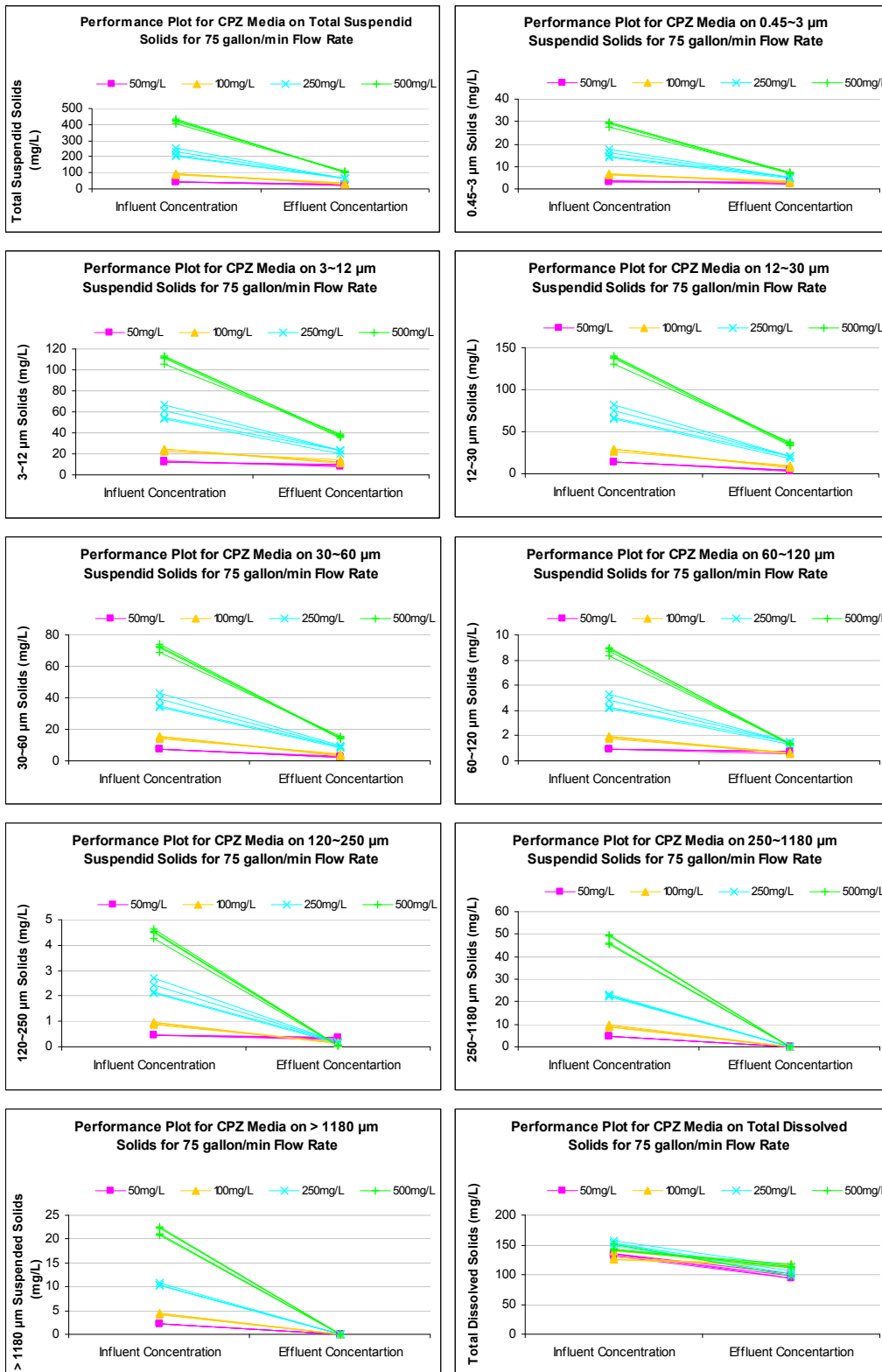

Figure 71. CPZ Mix™ Media 75 gpm Controlled Flow Test Results

5.1.6 *CPZ MixTM Media 150 gpm Controlled Flow Test Results*

Figure 72 shows the “High” flow rate (150 gpm, or 17 gpm/ft²) performance test results using the CPZ media. The removal rates were similar to the sand tests at this rate, and slightly decreased performance was seen with the high flow compared to the lower flow rate.

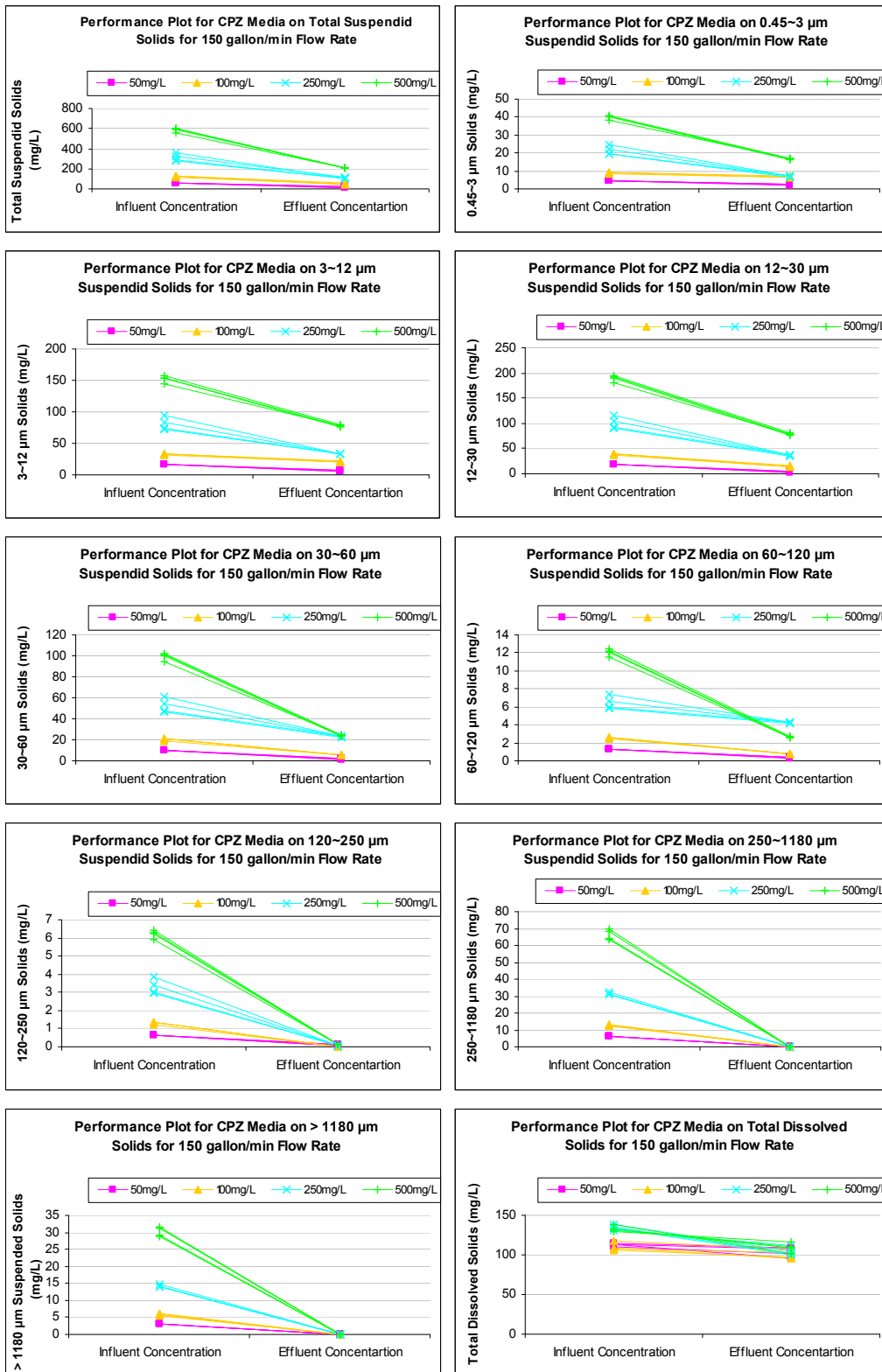

Figure 72. CPZ Mix™ Media 150 gpm Controlled Flow Test Results

During the controlled sediment tests of the full-sized treatment system, 90 to 100% of the particles larger than 30 μm , and from 40 to 90% of the smaller particles were captured, irrespective of the influent concentrations. These were similar results to those observed during the prior pilot-scale tests during actual rains (Pitt & Khambhammettu, 2006). During the tests having about 100 mg/L influent SSC, the effluent averaged about 20 mg/L, with removal rates of about 80%. During tests using 500 mg/L SSC influent, the effluent SSC averaged about 65 mg/L, with about 85% removal rates. During these initial tests, the treatment flow rates vs. head were very repeatable.

5.2 Full-Scale Monitoring Results during Rains

Performance monitoring during rains started in July 2010, and included measuring the influent and effluent concentrations and removal rates for solids, different particle size categories, metals, nutrients, and bacteria. A total of 20 events were monitored through April 2011.

5.2.1 *Example Monitoring Results for July 16, 2010 Event*

The following discussion is an example performance evaluation for the 0.78 inch July 16, 2010 rain, the first event monitored. Full analyses results for all the other events are included in Appendix H.

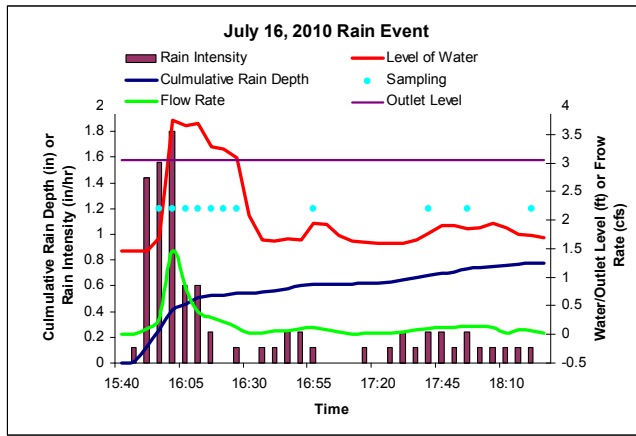

Site Information			
Site Name:	Bama Belle Parking Deck		
Site Location:	N(33°12'50'') W(87°34'17'')		
Drainage Area (ac):	0.9		
Percent Impervious (%):	67.8		
Runoff Curve Number	84.1		
Rational Number	0.6		
Storm Information – July 16, 2010 Storm			
	Goal	Value	QA note
Precipitation Total (in):	≥0.1	0.78	
Precipitation Duration (hr):	≥1	2.8	
Average Intensity (in/hr):	NA	0.28	
Peak Rain Intensity (in/hr):	NA	1.8	
Storm Volume (gal):	NA	11984	(0.498 in)
Maximum Discharge (cfs):	NA	1.5	
Ave Discharge Rate (cfs):	NA	0.16	
Peak to Ave Discharge Ratio:	NA	9.1	
Dry Period (hr):	≥6	≥6	
Estimated Rational Coefficient	NA	0.9	
Volumetric Runoff Coefficient	NA	0.6	

Sampling Information					
	Goal	IN	QA	Out	QA note
Aliquots:	≥5	11		11	
% Storm:	≥75	100		100	
	Value				
Total Bypass Volume (gal):	223				
% Bypassed to Total (%):	1.9				

Analysis Information						
EMC Concentration (mg/L, CFU/100mL, #)						
	IN	note	OUT	MDL	note	% Conc. Reduction
TSS	148.6		14.7	NA		90.1
SSC	-		-	NA		-
TDS	332.9		37.9	NA		88.6
Conductivity	448.0		205.0	0 to 199,900 μS		54.2
PH	6.57		6.87	-2.00 to 19.99		-4.6
Turbidity	55.8		7.5	0 to 4000 NTU		86.5
Total COD	120		77	0 to 150 mg/L		35.8
Dissolved COD	65		34	0 to 150 mg/L		47.7
Total P	2.19		2.17	0.00 to 3.50 mg/L		0.9
Dissolved P	1.65		0.95	0.00 to 5.00 mg/L		42.4
Ammonia	0.08		0.08	0 to 2.5 mg/L		0
Nitrate	1.4		0.7	0 to 5.0 mg/L		50.0
Total N	2		1	0 to 2.5 mg/L		50.0
Dissolved N	1		0	0 to 2.5 mg/L		100
Total Zn	0.09		BDL	0.02 mg/L		>77.8
Dissolved Zn	BDL		BDL	0.02 mg/L		-
Total Cd	BDL		BDL	0.005 mg/L		-
Dissolved Cd	BDL		BDL	0.005 mg/L		-
Total Cr	BDL		BDL	0.02 mg/L		-
Dissolved Cr	BDL		BDL	0.02 mg/L		-
Total Cu	0.02		BDL	0.02 mg/L		>0
Dissolved Cu	BDL		BDL	0.02 mg/L		-
Total Pb	0.013		BDL	0.005 mg/L		>61.5
Dissolved Pb	BDL		BDL	0.005 mg/L		-
E-Coli	-		-	10-24196		-
Enterococci	-		-	10-24196		-

Figure 73. July 16, 2010 Rain Event Summary

Figure 74 shows the particle size distribution plots for July 16, 2010 event for the influent effluent sample. The left particle size distribution plot includes the particle size between 0.45 μm to more than 1180 μm (the SSC, all of the particles detected in the influent), while right particle size distribution plot only includes the particle sizes between 0.45 μm to 75 μm (a common range associated with the TSS, which excludes the larger, easily settleable solids). This TSS definition was recently described by the solids committee of the American Society of Civil Engineers (ASCE) Guideline for Monitoring Stormwater Gross Solids (Environmental Water Resources Institute, Urban Water Resources Research Council, & Gross Solids Technical Committee, 2007) that defined TSS vs. SSC by indicating that TSS is less than 75 μm .

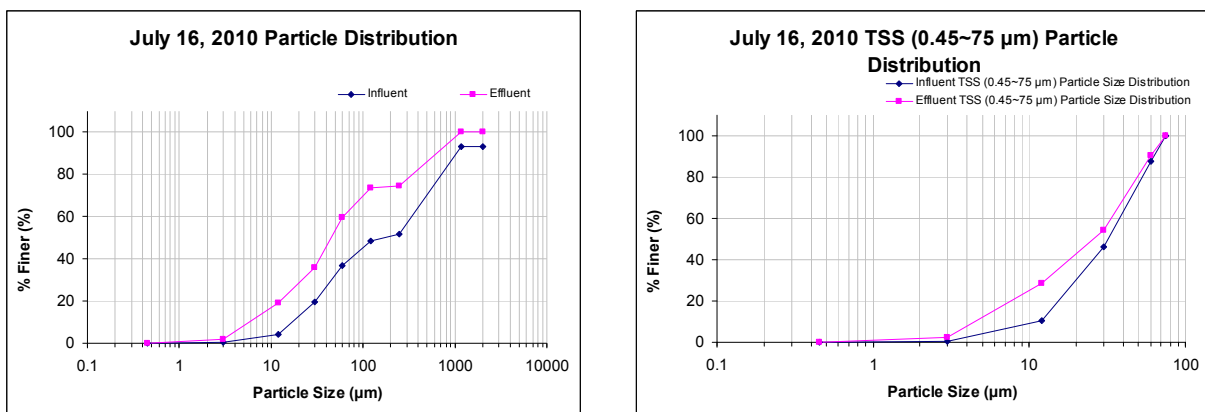

Figure 74. Particle Size Distribution Plot for July 16, 2010 Event

Figure 75 shows the cumulative flow rate plot for the storm. It shows the peak rate at 100% (about 1.3 cfs) and the smaller flows observed. The percentages of time that the flows were less than the flows indicated were plotted. For the July 16, 2010 event, the median flow was only about 0.1 CFS, less than 10% of the peak flow observed.

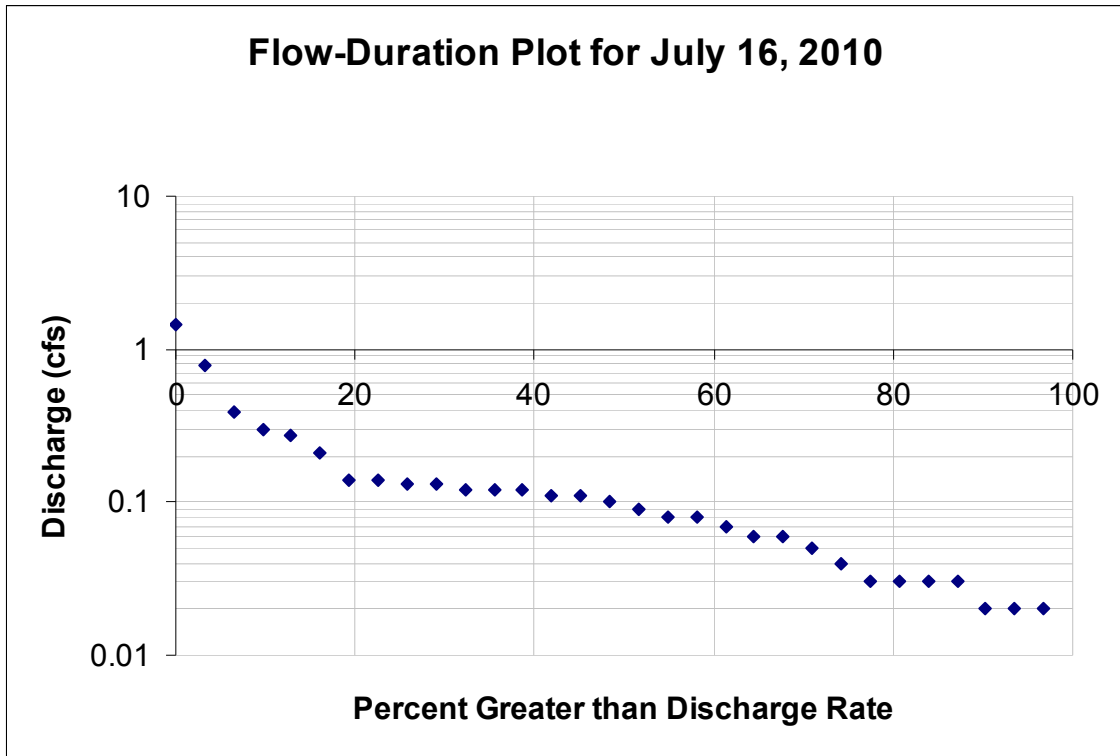

Figure 75. Cumulative Flow Rate Plot for July 16, 2010 Event

Figure 76 shows the Flow vs. Stage graph for the July 16, 2010 event. The plot indicates that the flow rate was relatively constant, excluding the flow rates that occurred during bypassing. There were six monitoring points when the partial bypassing was occurring.

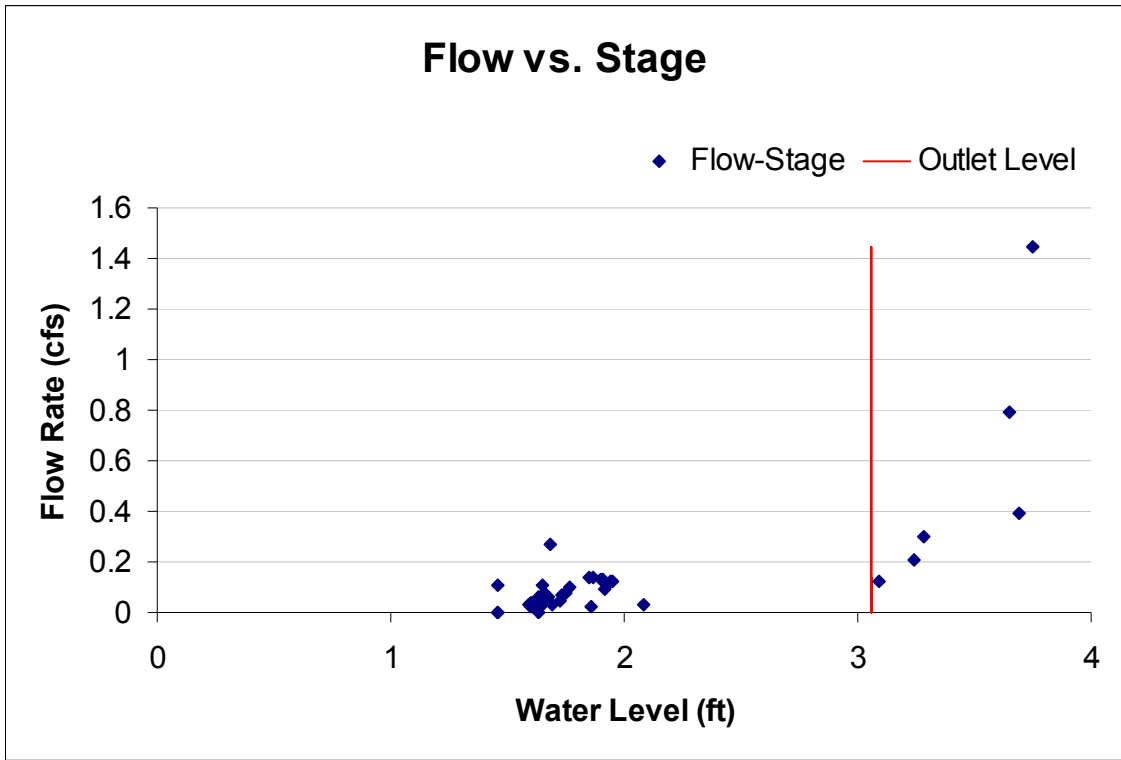

Figure 76. Flow vs. Stage Graph for July 16, 2010 Event

Figure 77 shows the continuous monitoring of the water level within the sump (solid red line during the event and dot purple line after the event). The plot verifies the performance of the drain down which was designed to keep the water level lower than the bottom of the media soon after the storm ends to minimize the possibility of anaerobic conditions forming in the media. The graph shows that the water level dropped below the media soon after the storm.

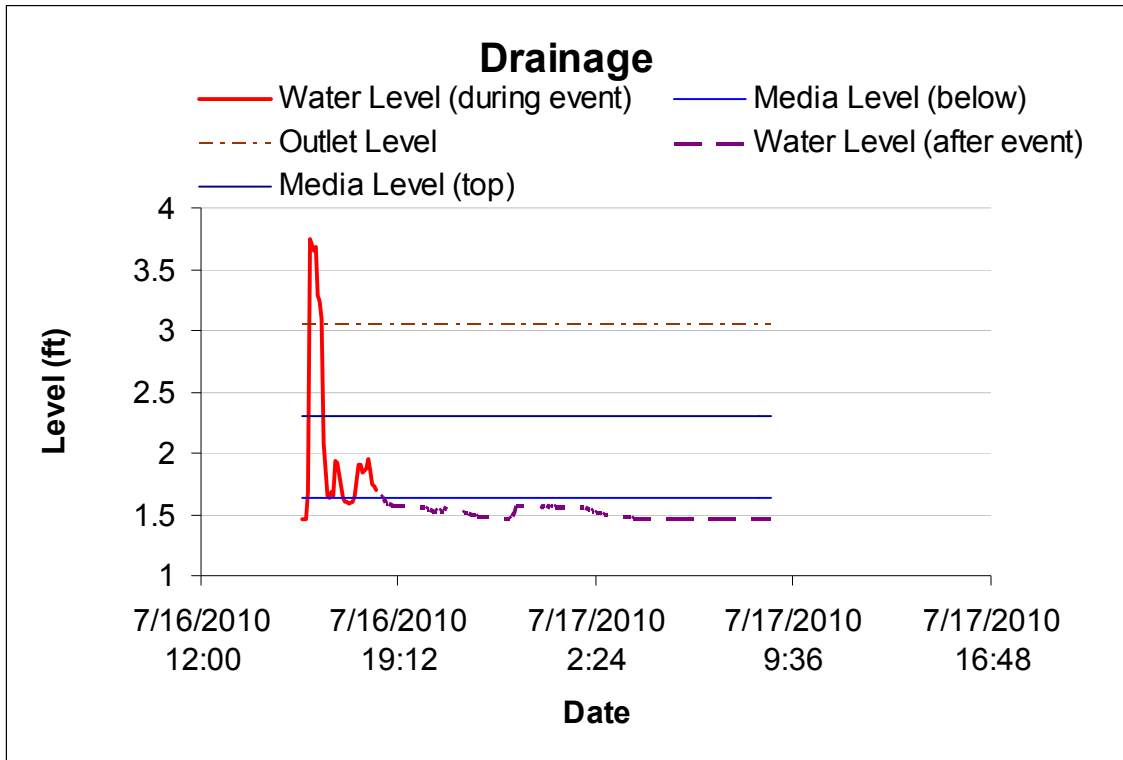

Figure 77. Level of Drainage for July 16, 2010 Event

5.2.2 Actual Monitoring Results for SSC Analysis

Table 42 summarizes the SSC removal results for all of the monitored events (excluding the gross solids captured in the sump). The results for the other monitored pollutants are shown in Appendix H.

Table 42. Actual Monitoring SSC Analysis Summary (without Sump Accumulations)

	Total Runoff (inches)	Influent SSC (mg/L)	Effluent SSC (mg/L)	Reduction (%)
16-Jul-10	0.50	148.6	14.7	90.1
14-Aug-10	0.39	140.6	7.6	94.6
28-Aug-10	0.68	85.3	4.8	94.4
26-Sep-10	0.17	53.6	10.0	81.3
12-Oct-10	0.03	59.0	18.0	69.5
26-Oct-10	0.34	94.5	21.7	77.0
28-Oct-10	0.59	103.6	21.7	79.1
2-Nov-10	0.63	72.0	37.0	48.6
3-Nov-10	0.60	87.0	19.0	78.2
11-Dec-10	0.49	131.0	50.3	61.6
25-Dec-10	0.15	115.0	40.6	64.7
31-Dec-10	0.31	80.0	29.0	63.8
1-Jan-11	1.34	52.0	17.0	67.3
10-Jan-11	0.16	29.0	6.0	79.3
25-Jan-11	0.31	43.0	17.9	58.4
25-Feb-11	0.68	27.0	6.3	76.7
4-Mar-11	0.46	33.0	11.6	64.8
28-Mar-11	0.05	24.0	21.1	12.1
29-Mar-11	0.16	37.0	11.6	68.6
11-Apr-11	0.28	101.0	69.0	31.7
Median	0.37	76	17.95	76.4
Average	0.42	75.8	21.7	68.1
Standard Deviation	0.30	39.1	16.4	20.0
COV	0.72	0.5	0.8	0.3

Flow Weighted Influent SSC (mg/L) = 74.2

Flow Weighted Effluent SSC (mg/L) = 20.3

Flow Weighted SSC Reduction (%) = 72.7 (not including gross solids removals in the sump)

The full-scale Upflow Filter performed well under the actual storm events having approximately 70% average reductions in SSC (excluding gross solids removal in the sump); standard deviation of the performance was about 20 mg/L, resulting in a removal COV of about 0.3, which was quite small. These were similar results to those observed during the prior pilot-scale tests during rains (Pitt & Khambhammettu, 2006). The Bama Belle site had an average influent SSC concentration of 76 mg/L and an average effluent SSC concentration of about 22

mg/L. The City Hall pilot-scale rain runoff SSC average influent concentration was 64 mg/L, and the average effluent SSC concentration was about 19 mg/L. Although the average influent and effluent SSC concentrations and the removal rates were similar for both locations, for many samples, the City Hall pilot-scale site had much lower influent SSC concentrations compared with the Bama Belle site.

Table 43 summarizes the results for all the storm events that have been sampled at the Bama Belle site. For most constituents, the upflow filter had statistically significant reductions, excluding some of the dissolved nutrients and the dissolved metals that were not detected in the influent. Few dissolved metal concentrations were detected in the influent, but none were detected in the effluent. Overall, the upflow filter has significant treatability levels under a wide range of flows for many pollutants.

Table 43. Summary of Full-Scale UpFlow Filter Actual Storm Monitoring

	Average influent concentration (all mg/L, except for bacteria that are #/100mL, turbidity that is NTU, and metals that are µg/L, conductivity that is µs/cm (and COV))	Average effluent concentration (all mg/L, except for bacteria that are #/100mL, turbidity that is NTU, and metals that are µg/L, conductivity that is µs/cm (and COV))	Calculated percentage removal based on average influent and average effluent concentrations of individual event pairs (median of individual sample pair reductions)*	Probability that influent ≠ effluent (nonparametric sign test) (significant reduction at 95% level; “S=significant” or “N=not significant”)
TSS	62.3 (0.5)	20.5 (0.7)	66.0 (70.9)	>99% (S)
SSC	75.8 (0.5)	21.7 (0.8)	68.1 (76.4)	>99% (S)
TDS	112.8 (0.5)	66.9 (0.5)	34.8 (31.6)	>99% (S)
Conductivity	124.0 (0.8)	85.9 (0.5)	23.2 (26.5)	>99% (S)
Turbidity	18.2 (0.7)	7.4 (0.5)	50.3 (54.0)	>99% (S)
Total COD	42.1 (0.9)	24.3 (1.0)	43.4 (42.9)	>99% (S)
Dissolved COD	25.2 (1.0)	16.3 (1.2)	41.5 (36.4)	>99% (S)
Total Phosphorus	1.28 (0.4)	0.97 (0.5)	21.6 (30.5)	>99% (S)
Dissolved Orthophosphate	0.64 (0.6)	0.50 (0.5)	21.1 (9.3)	>99% (S)
Dissolved Total Phosphorus	0.62 (0.1)	0.56 (0.1)	10.2 (6.6)	97% (S)
Ammonia	0.09 (0.8)	0.04 (0.8)	52.4 (62.5)	>99% (S)
Nitrate	0.9 (0.5)	0.6 (0.3)	27.8 (18.8)	>99% (S)
Total Nitrogen	3.4 (0.3)	1.8 (0.4)	45.9 (33.3)	99% (S)
Dissolved Nitrogen	2.1 (0.3)	1.0 (0.6)	57.9 (50.0)	81% (N)
Total Zinc	0.08 (0.4)	BDL	>74.2 (>77.8)	NA
Dissolved Zinc	0.075 (0.1)	0.03 (NA)	73.3 (60.0)	>99% (S)
Total Cadmium	BDL	BDL	NA	NA
Dissolved Cadmium	BDL	BDL	NA	NA
Total Chromium	BDL	BDL	NA	NA
Dissolved Chromium	BDL	BDL	NA	NA
Total Copper	0.08 (1.2)	0.04 (0.7)	50.0 (-14.3)	>99% (S)
Dissolved Copper	0.05 (0.6)	0.05 (NA)	0.0 (NA)	NA
Total Lead	0.012 (0.1)	BDL	>58.3	NA
Dissolved Lead	BDL	BDL	NA	NA
E-Coli	6620 (1.7)	3091 (1.8)	54.3 (66.8)	>99% (S)
Enterococci	7368 (0.8)	4825 (1.0)	42.1 (59.4)	>99% (S)

* not flow-weighted; these are averages of the removals calculated for each pair of

observed influent and effluent concentrations for each event.

5.2.3 Influent and Effluent TSS Concentrations Time Series Plots

Figure 78 shows the influent and effluent concentrations of TSS during the monitoring period. TSS influent concentrations varied more than the TSS effluent concentrations as shown in Figure 79, indicating the better performance of the upflow filter when the influent concentrations were high.

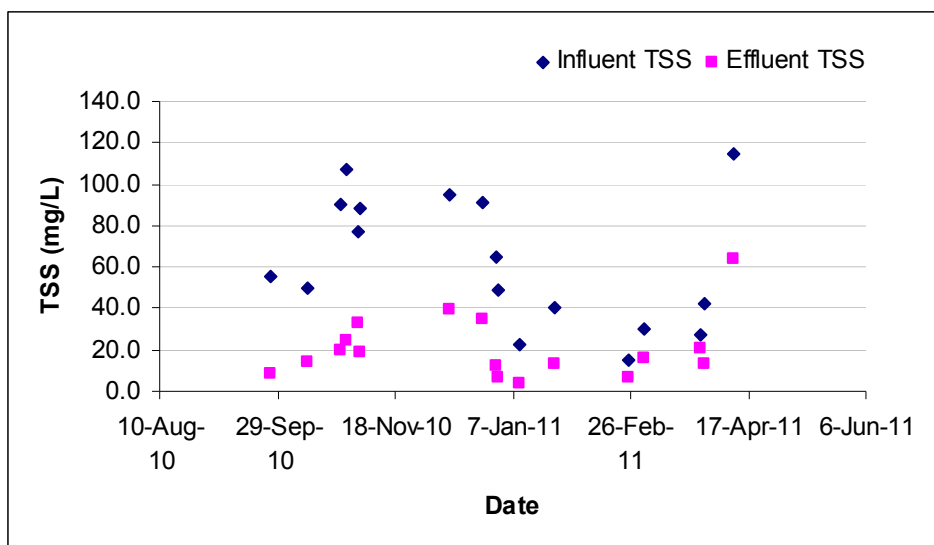

Figure 78. Influent and Effluent Concentrations of TSS

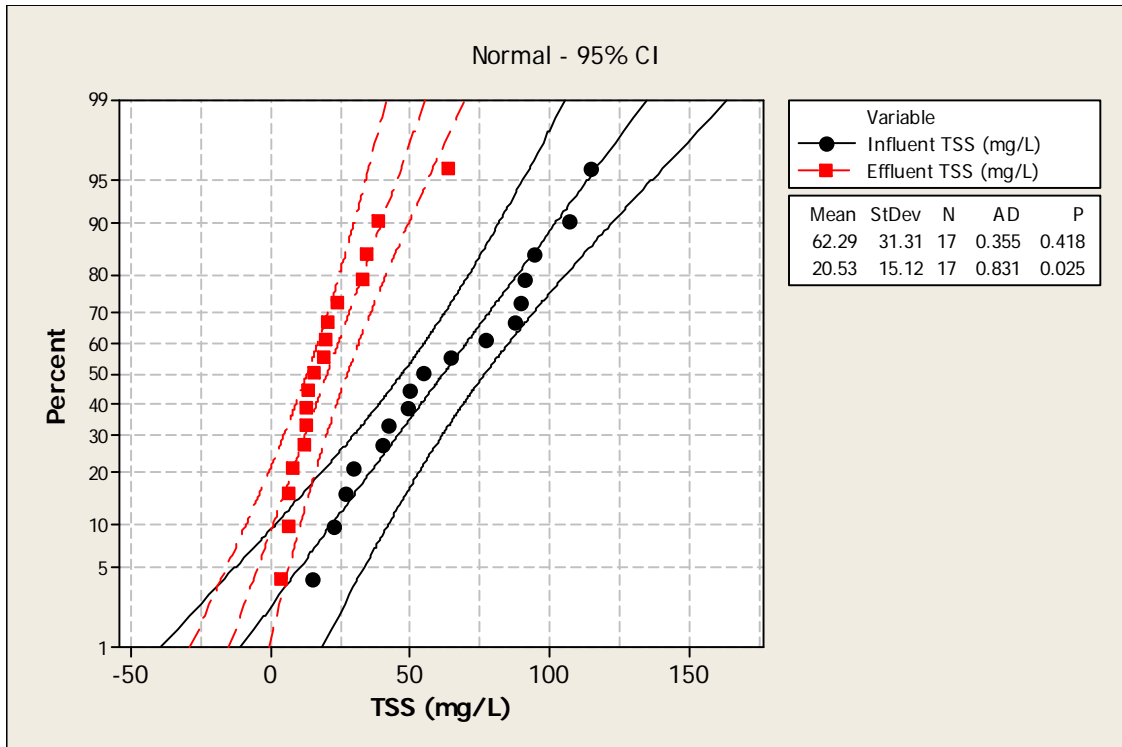

Figure 79. Probability Plot of Influent and Effluent TSS

As shown in Figure 80, higher variations of the influent TSS concentrations were related to the rain depth. In general, the larger rain depths tend to generate higher influent TSS concentrations, but this was not consistent. Indeed many of the high TSS samples were collected from the larger rain depth events except the few data points shown in red. Previous research conducted by Pitt (1985) shows similar trend for the samples taken from the relatively small paved area during rains, while other research conducted by Pitt et al (2008) during the development of NSQD database shows that there are no obvious trends of concentration associated with rain depth for the area with mixed land uses.

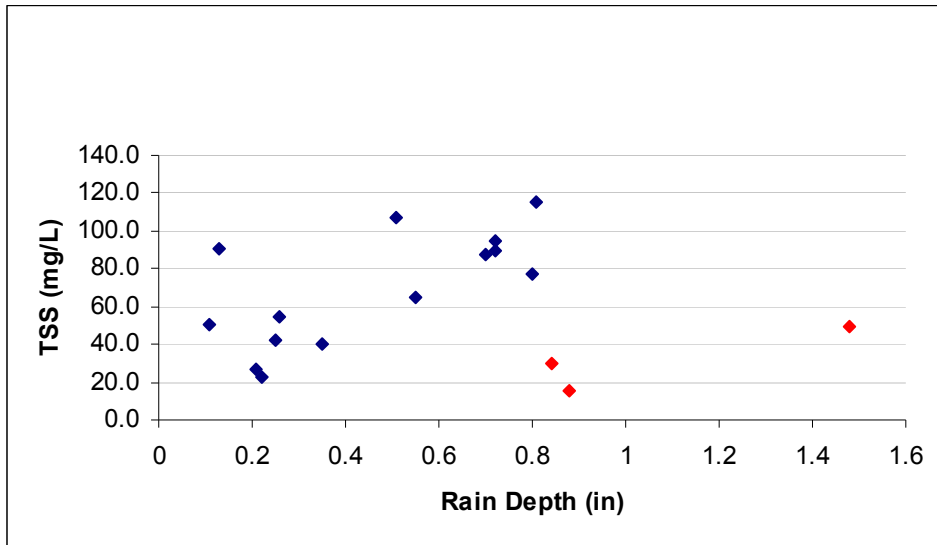

Figure 80. TSS influent vs. Rain Depth Graph

5.2.4 *Influent and Effluent SSC Concentrations Time Series*

Figure 81 shows the influent and effluent concentrations of SSC during the monitoring period. The SSC influent concentrations had larger variations than the SSC effluent concentrations as shown in Figure 82.

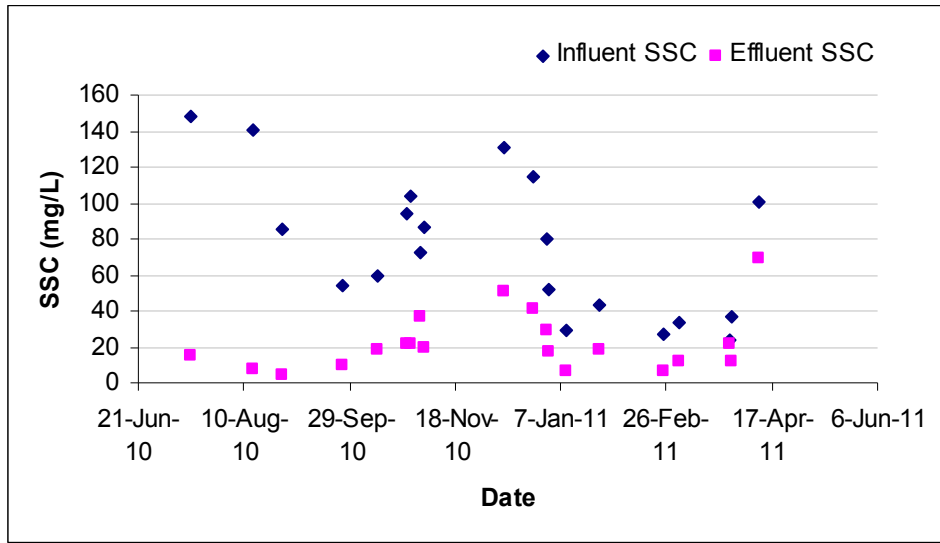

Figure 81. Influent and Effluent Concentrations of SSC

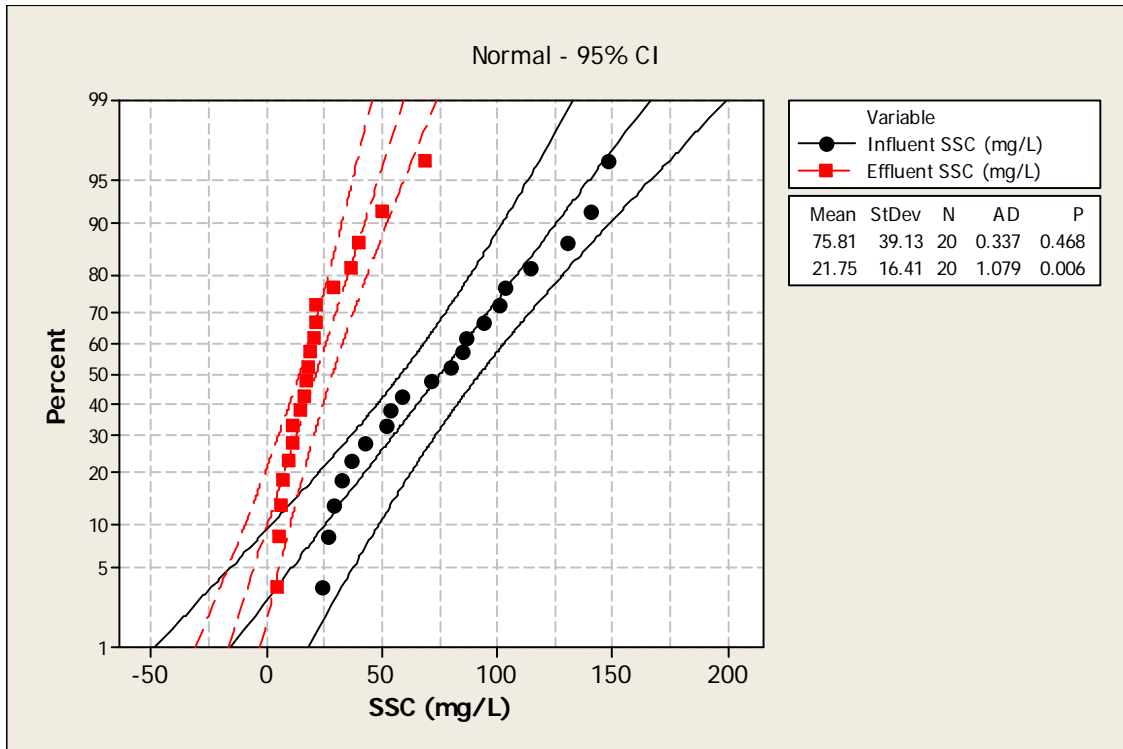

Figure 82. Probability Plot of Influent and Effluent SSC

Figure 83 shows the SSC influent vs. rain depth graph. It shows much greater scatter than the TSS patterns (a few large rain depths having lower SSC concentrations were plotted with red dots).

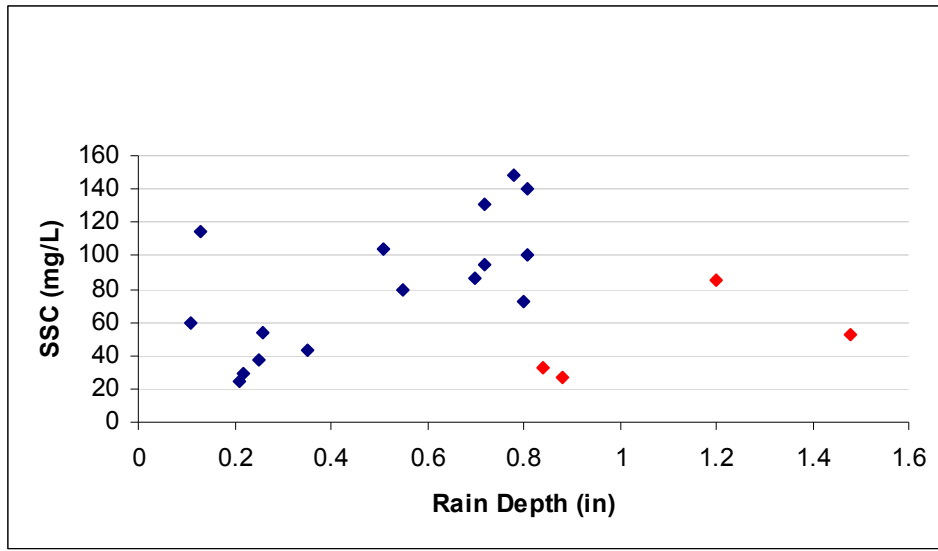

Figure 83. SSC influent vs. Rain Depth Graph

5.2.5 Influent and Effluent Turbidity Time Series Plots

Figure 84 shows the influent and effluent turbidity values during the monitoring period. This plot shows that there were higher turbidity values during the early events, which then seemed to decrease with time. However, the effluent turbidity was relatively constant throughout the monitoring period (COV of 0.5) as shown in Figure 85.

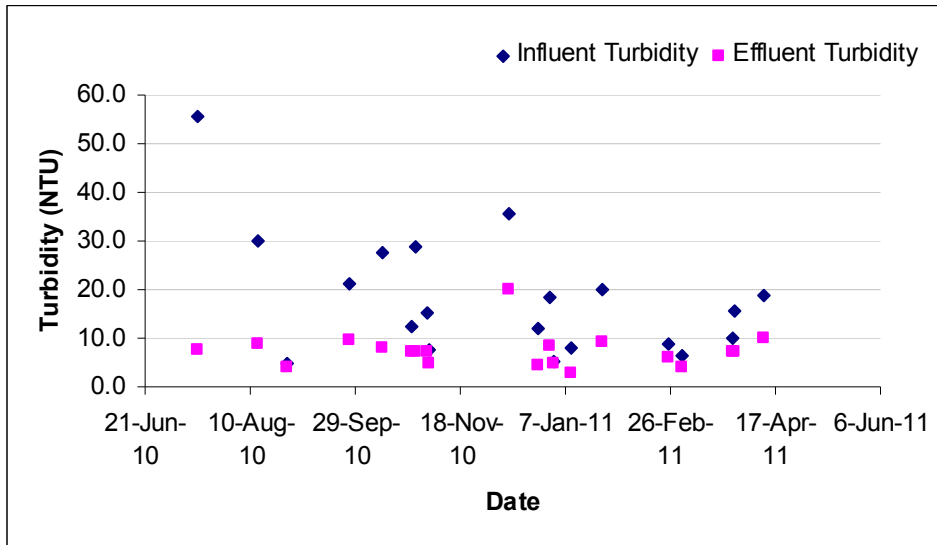

Figure 84. Influent and Effluent Turbidity

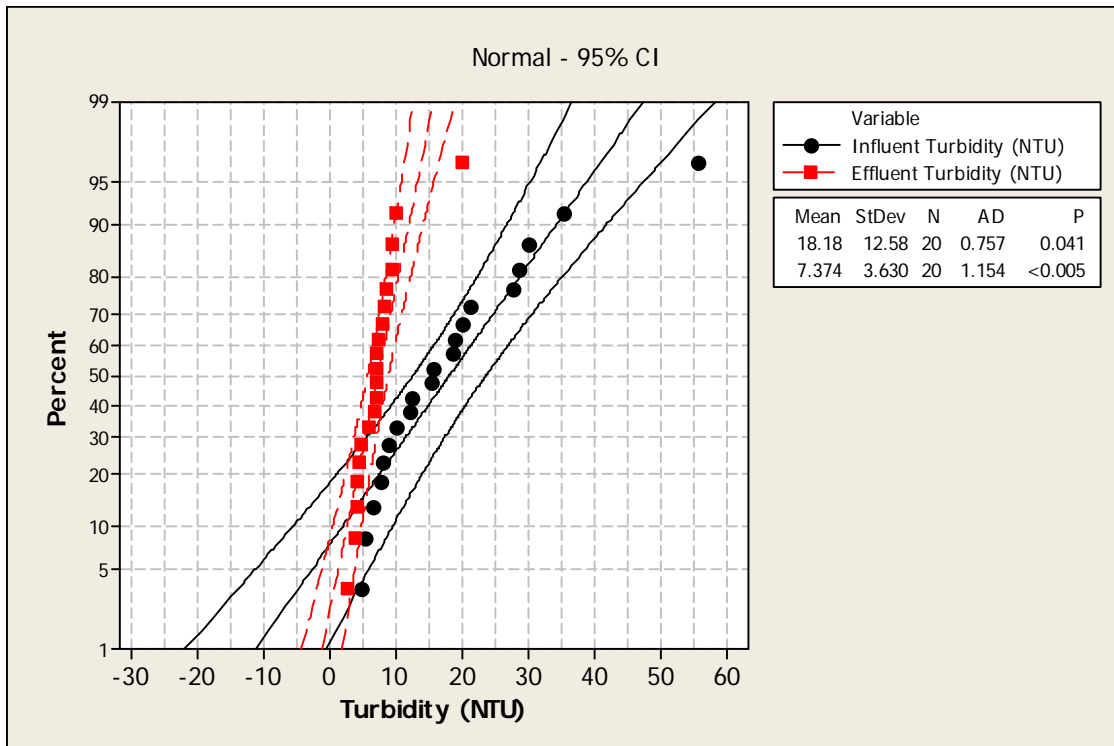

Figure 85. Probability Plot of Influent and Effluent Turbidity

5.2.6 Removal Capability Change with Time for SSC

Figure 86 shows the removal capability change for the SSC during the monitoring period for the runoff-producing rains. This plot indicates that the reduction rate decreased with time. During the beginning 5 months, filter media alone removing more than 80% of the SSC, while after about 6 months, the filter media was removing from 70 to 80% of the SSC. The filter media was still removing more than 60% of SSC after approximately nine months, and the removal rate continued to degrade until the end of the monitoring period. It is likely that the filter bags experienced partial break-through after about four or five months. Because of the large amount of rainfall and runoff at the test site (about 55 inches per year of rainfall), the media bags should probably be replaced after about 20 inches of rain in order to obtain the highest level of treatment over an extended timeperiod. If the influent SSC was much greater than experienced at this site, the bags may need to be exchanged more frequently.

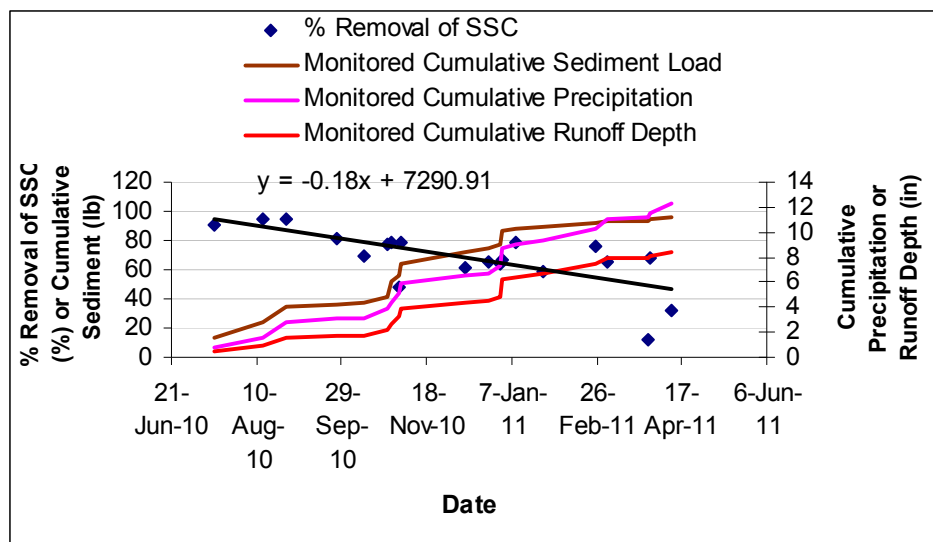

Figure 86. Removal Capability Change for SSC

5.2.7 Removal Capability Change for TDS

Figure 87 plots the removal capability change for TDS during the monitoring period. The result was similar to the SSC removal trends, however; the reduction rate was reduced much faster than for SSC. The equation in Figure 87 shows a reducing linear trend of removal percentages of TDS with time. The slope and intercept terms were both significant, having p-values of 0.04 (<0.05). There was more than an 80% TDS reduction during the initial 3 months, with this reducing slightly after 6 months. It also shows some negative reductions near the end of the monitoring period, possibly caused by dissolution of some of the captured material in the sump after the extended period. This may indicate a recommended sump cleanout after about 6 months.

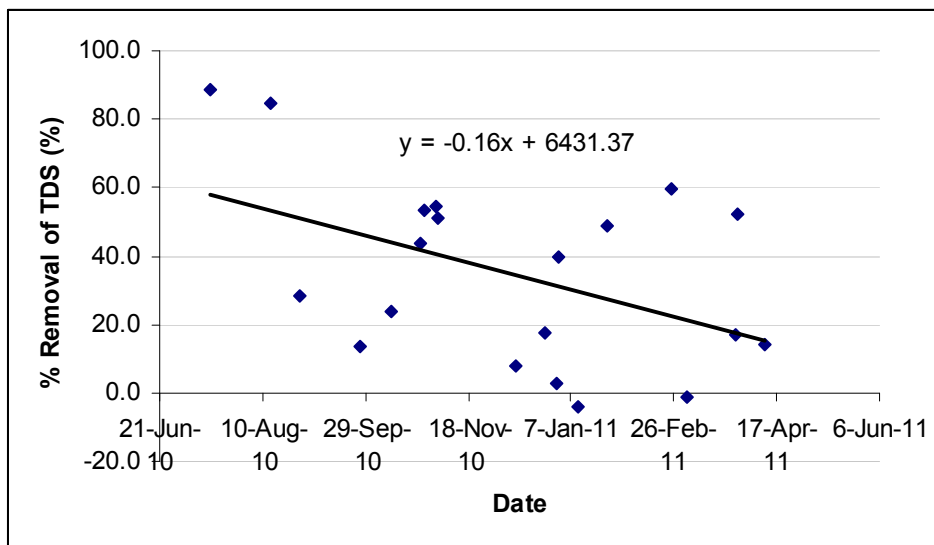

Figure 87. Removal Capability Change for TDS

5.2.8 Continuous Sump Turbidity Monitoring

Figure 88 shows the continuous sump turbidity measurement by the YSI 6000 sonde during the monitoring period. As indicated earlier, the influent sonde was used to measure the sump turbidity of the standing water after the end of the rain event. It was replaced into the influent monitoring position when rain was expected. This figure indicates that the turbidity in the sump was about 20 NTU during the beginning the monitoring period when little debris was accumulated in the sump. The turbidity leveled off to about 40 NTU after about 4 months. Although instantaneous influent turbidity values during the rain events often exceeded 100 NTU (to more than 1000 NTU in some observations), the sump turbidity values never exceeded 50 NTU. Higher turbidity values in the sump at the later periods of monitoring may indicate that some scour of suspended particles from the captured sump material may have occurred.

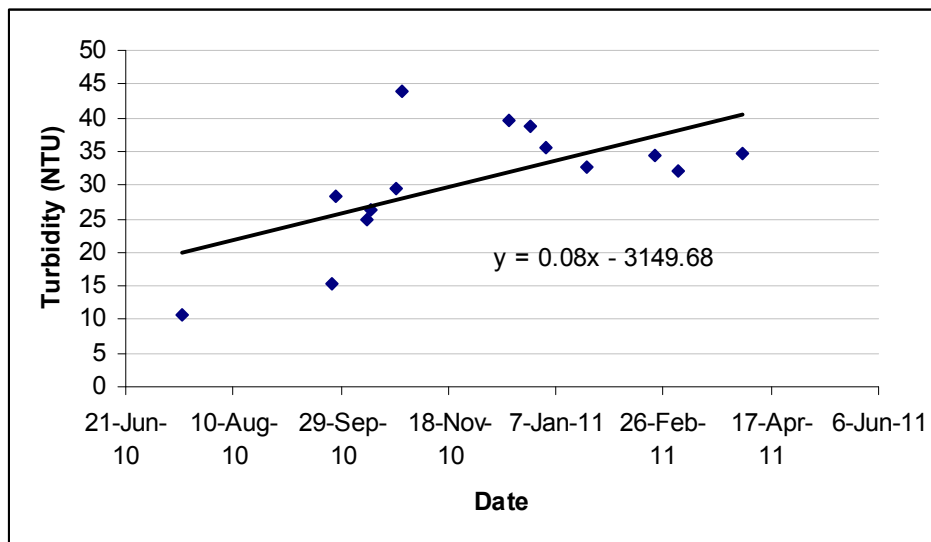

Figure 88. Continues Sump Turbidity Monitoring

5.2.9 *Bypassing Flow Rate Monitoring*

Another reason for decreased performance with time may be associated with reduced flow rates, causing increased bypassing. Therefore, bypassing amounts, and stage vs. flow rates were examined for all events for evidence of trends. Figure 89 shows the monitored bypassing flow rates (box plot), bypassing water level (red dot plot), and outlet level (blue line plot) during the monitoring period for each event. The water levels were only available from the beginning event of July 16, 2010 up to December 11, 2010 (8 events in total of 20) due to the malfunction of the area velocity sensor at the sump. Several previous researches show that the degradation of the performance occurs when the media is clogged or saturated by pollutants and bypassing increases (Andoh et al., 2009a, 2009b; Khambhammettu, 2006; Penn State Harrisburg, 2007; Pitt & Khambhammettu, 2006; Pratap, 2004; Urbonas, 1999; US Infrastructure, 2003). Figure 86 shows the Removal Capacity Change for SSC and illustrates the degradation of performance with time. Figure 89 does not indicate any significant clogging, as the bypassing flow rates and stages do not increase with time. However, Figure 78 indicates that the influent TSS was decreasing, while the effluent TSS concentration was relatively constant with time. Percentage reductions were highly dependent on influent concentrations, so decreasing influent concentrations would be expected to result in decreasing removal rates. Also during the first 6 months (from July 16, 2010 to December 11, 2010), the media was still removing more than 70 to 80% of the TSS while the bypassing volume was not significantly increased. The TDS removal rate dropped rapidly during the beginning two events and the effluent TDS quality degraded.

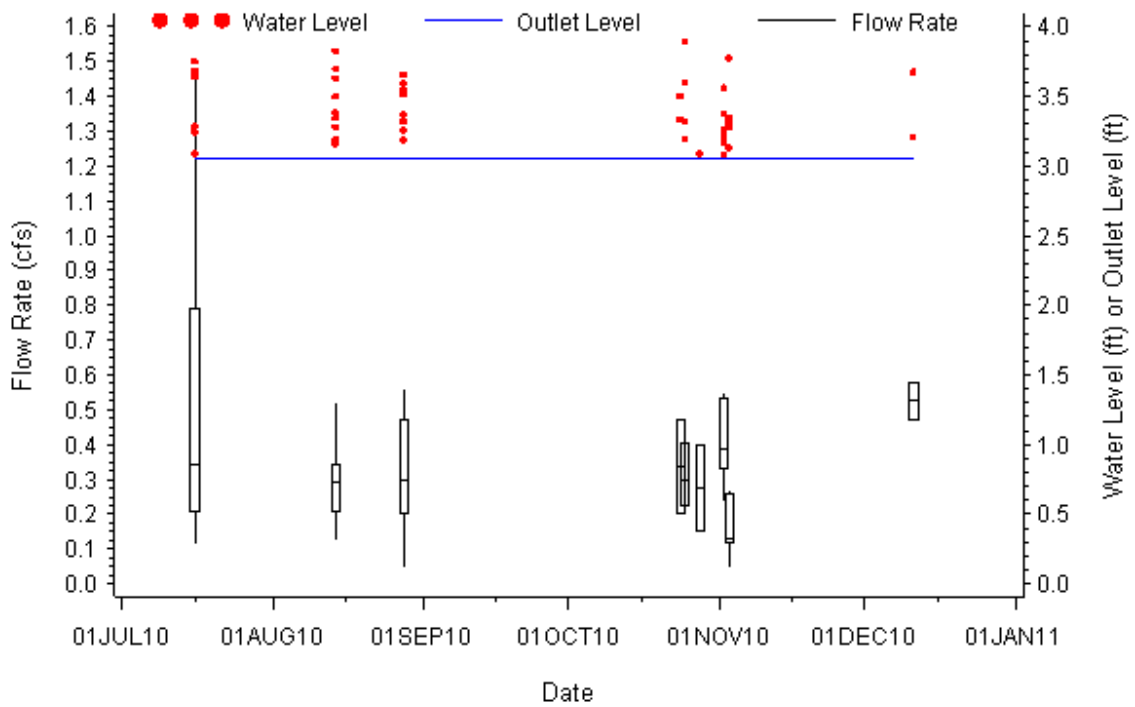

Figure 89. Bypassing Flow Monitoring

5.2.10 Sump Sediment Analysis

Sump samples were collected using a dipper grab sampler and analyzed by dry sieving. During the sampling process, the depth of the sediment was measured using a stainless steel rod in order to quantify the sediment load during the monitoring period. The sediment depth was measured to be approximately 8 inches and calculated to be about 8.4 ft³ of material retained. Figure 90 shows the particle size distribution of the sump material. Most of the sump material was granular, coarse sands to finer sands, with some cohesive materials. However, about 8% of

the sump material by mass was organic debris (mostly small twigs and leaves). More than 80% of the sump materials were larger than 250 μm and ranged up to 4,760 μm in size.

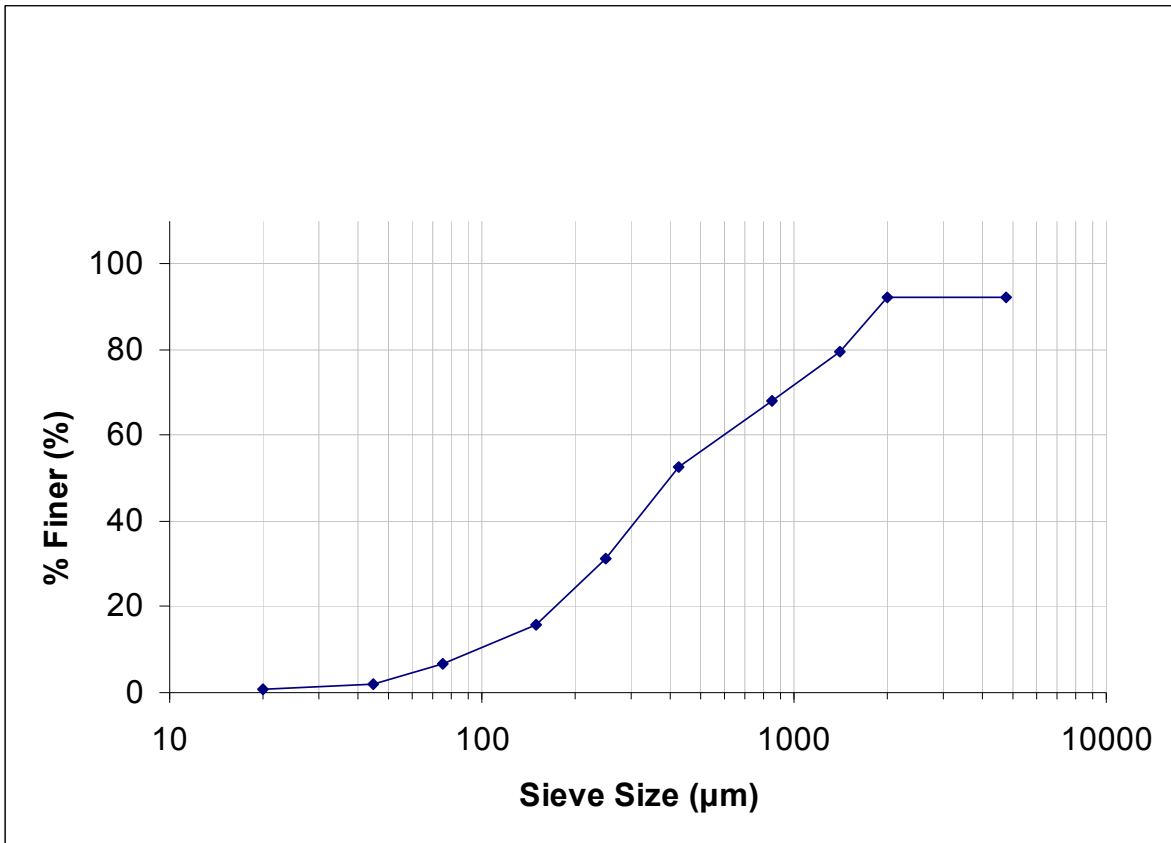

Figure 90. Particle Size Distribution for Sump Material

Table 44 summarizes the expected mass balance of particulate material removed by the Up-Flo[®] Filter during the sampling period, considering both the measurements from the automatic samplers (for suspended material <250 μm in size) and the larger material collected in the sump (>250 μm in size). This table shows that the Up-Flo[®] Filter removed about 100% of sediments larger than the 250 μm and approximately 67% of particulates less than 75 μm . The

Up-Flo[®] Filter also retained all the floatable materials, such as plastic bottles and bags as well as the small branches/twigs and leaves carried into the filter during the storm events.

Table 44. Calculated Mass Balance of Particulate Solids for Monitoring Period

Particle size range (μm)	SS influent mass (lb)	SS effluent mass (lb)	% Reduction (%)
0.45-3	0.3	0.2	38.8
3-12	10.7	5.1	52.0
12-30	35.7	12.4	65.2
30-60	81.2	12.4	84.8
60-75	24.3	1.7	92.9
75-150	43.0	1.3	97.1
150-250	21.9	2.8	87.1
250-425	21.4	0.4	98.3
425-850	30.1	0	100
850-1400	21.2	0	100
1400-2000	15.7	0	100
2000-4760	17.6	0	100
>4760	10.9	0	100
Sum	333.8	36.3	85.8

Chapter 5 examined the field performance result of the full-scale upflow filter (the Up-Flo[®] Filter) for the controlled and during actual storm events. The Up-Flo[®] Filter showed the significant treatability levels under a wide range of flows for many pollutants. Chapter 6 compares these detailed observations in the different testing protocols.

CHAPTER 6

6: EXAMINATION OF EACH PROTOCOL

Each protocol applies slightly different criteria to verify the performance of a stormwater treatment device. The following analyses were conducted using the available data obtained during the various monitoring tests of the Up-Flo[®] Filter, applying the four main protocols in order to evaluate their similarities and differences.

6.1 Technology Assessment Protocol – Ecology (TAPE) Protocol Analysis

TAPE is a Washington State based protocol, published by the Washington Department of Ecology in 2001 (Ecology, 2001). Ecology's basic requirement for acceptance of the technology is to achieve 80% removal of total suspended solids (TSS) when influent concentrations are greater than 100 mg/L and less than 200 mg/L. For influent TSS concentrations greater than 200 mg/L, it must set higher treatment goals. Influent concentrations less than 100 mg/L are required to achieve effluent TSS concentrations of 20 mg/L, or less. Ecology also specifies a criterion for fine particles in the TSS fraction (less than 50 μm mean size) to achieve the 50% removal rate for concentrations greater than 100 mg/L and less than 200 mg/L and intended effluent concentrations for these fine particle sizes of 50 mg/L for influent concentrations less than 100 mg/L. Other criteria for TAPE are summarized in Table 45.

One of the criteria that make TAPE different from other protocols is that TAPE acknowledges that small rain depths may occur (less than 0.04 inches) during the 6 hours of antecedent time between each monitored storm events, whereas the other protocols do not allow any rain to occur during the dry period for clear hydraulic separations of each event. Another unique criterion is that TAPE requires a minimum rain duration of 1 hour while other protocols only require minimum rain depth.

Table 45. TAPE Protocol Criteria

Criteria	
Applicable State	Washington
Minimum Number of Monitored Events	12-35
Minimum Rain Depth (inches)	0.15
Minimum Rain Duration (hours)	1
Minimum Number of Sub-Samples per Event	10
Minimum Dry Period between events (hours)	6 hours with total of less than 0.04 inches of rain (during 6 hours)

6.1.1 TAPE Criteria Verification for each Sample Event

According to the table 45, some of the obtained sample data does not satisfy the criteria of the TAPE protocol. Table 46 describes the whole sample data set and shows which event samples were qualified for the TAPE verification.

Table 46. Sample Qualification Verification for TAPE Protocol

Event Date	Rain depth (inch) : >0.15	Rain Duration (hours) : >1	Subsamples (#) : >10	Dry Period (hours) : >6	Qualify? Yes or No (Reason)
16-Jul-10	0.78	2.8	11	>6	Yes
14-Aug-10	0.81	1.6	9	>6	No (subsample)
28-Aug-10	1.2	3.4	16	>6	Yes
26-Sep-10	0.26	6.2	8	>6	No (subsamples)
12-Oct-10	0.11	1.4	5	>6	No (rain, subsamples)
26-Oct-10	0.72	5.5	8	>6	No (subsamples)
28-Oct-10	0.51	2.1	12	>6	Yes
2-Nov-10	0.8	3.9	15	>6	Yes
3-Nov-10	0.7	6.3	14	>6	Yes
11-Dec-10	0.72	2.9	11	>6	Yes
25-Dec-10	0.13	5.0	5	>6	No (rain, subsamples)
31-Dec-10	0.55	1.2	7	>6	No (subsamples)
1-Jan-11	1.48	4.9	30	>6	Yes
10-Jan-11	0.22	4.8	5	>6	No (subsamples)
25-Jan-11	0.35	5.1	7	>6	No (subsamples)
25-Feb-11	0.88	3.0	16	>6	Yes
4-Mar-11	0.84	2.5	11	>6	Yes
28-Mar-11	0.21	2.1	5	>6	No (subsamples)
29-Mar-11	0.25	3.8	4	>6	No (subsamples)
11-Apr-11	0.81	3.1	6	>6	No (subsamples)

Table 46 indicates that only nine of the twenty monitored events were qualified according to the TAPE protocol criteria. The majority of the unqualified events were excluded by the subsample criterion, while two also did not meet the minimum rain depth. As described in the

previous chapter, smaller rains generate less runoff and may not provide enough volume for needed subsamples using typical automatic sampler programs. During the actual field monitoring, our protocol was designed to collect every single storm regardless of the storm characteristics, however; about half of the storms were not qualified for the TAPE protocol verification criteria.

6.1.2 *TAPE Qualified Events and UpFlow Filter Performance*

Nine of the qualified events were analyzed to evaluate the performance of the Up-Flo[®] Filter. TAPE's primary criteria for acceptance of the device is to have 80% reduction of the TSS for more than 100 mg/L and less than 200 mg/L influent concentrations, or to have a maximum of 20 mg/L effluent concentrations when the influent TSS concentrations were less than 100 mg/L. TAPE specifies a lower allowable performance criterion for samples having a lower mean particle size (less than 50 micrometers). In these cases, the required reduction rate criterion is reduced to 50% instead of 80% when the influent concentrations were greater than 100 mg/L and less than 200 mg/L. If the influent concentrations were less than 100 mg/L, a maximum 50 mg/L effluent concentrations are allowed for those samples having mean particle sizes less than 50 micrometers. Table 47 summarizes these evaluation results. Treatability of the device was determined first by the categorizing the influent TSS concentrations as between 100 and 200 mg/L or less than 100 mg/L. If the influent concentration falls in the first category, then the removal percentage of 80% was considered as the determination factor. If the influent concentration was below 100 mg/L, then the effluent concentration of 20 mg/L was used as a criterion. It also considered the mean particle sizes determined by the Coulter Counter/sieve analyses in order to determine if the device needs to satisfy the alternative performance standard for finer particle sizes.

Table 47. Qualified Events and UpFlow Filter Performance Evaluation by TSS

Event Date	Mean Particle Size (µm)	Influent TSS (mg/L)	Influent TSS 100~200 mg/L: Yes/No	Applicable Performance Criteria (% removal or effluent conc)	Effluent TSS (mg/L)	Effluent TSS less than 20 mg/L (or 50 mg/L for less than 50 mean micron): Yes/No	Reduction Rate (%)	UpFlow filter has acceptable treatability by TAPE: Yes/No
16-Jul-10	49.6	62.1*	No	50 mg/L	9.7*	Yes	84	Yes
28-Aug-10	51.7	17.6*	No	20 mg/L	2.7*	Yes	95	Yes
28-Oct-10	76.9	107	Yes	80%	24	No	78	No
2-Nov-10	73.7	77	No	20 mg/L	33	No	57	No
3-Nov-10	49.6	88	No	50 mg/L	19	Yes	78	Yes
11-Dec-10	36.3	95	No	50 mg/L	39	Yes	59	Yes
1-Jan-11	57.3	49	No	20 mg/L	7	Yes	86	Yes
25-Feb-11	43.3	15	No	50 mg/L	7	Yes	53	Yes
11-Apr-11	45.6	115	Yes	50%	64	No	44	No

* TSS values were not analyzed for the first two monitored events, and were therefore estimated from the SSC concentrations (TSS between 0.45 and 75 µm)

The TSS removal criteria also should be reviewed regarding differences between the TSS and SSC analysis methods. Much of the new research examining stormwater treatment uses SSC

as an analytical method for particulate solids instead of the traditional TSS method. As an example Clark and Siu (2008) show that the SSC method has accuracy and precision advantages over TSS for a wide range of conditions. Table 48 therefore summarizes the evaluation of the performance using the SSC concentrations.

Table 48. Qualified Events and UpFlow Filter Performance Evaluation by SSC (excluding sump gross solids samples)

Event Date	Mean Particle Size (µm)	Influent SSC (mg/L)	Influent SSC 100~200 mg/L: Yes/No	Applicable Performance Criteria (% removal or effluent conc)	Effluent SSC (mg/L)	Effluent SSC less than 20 mg/L (or 50 mg/L for less than 50 mean micron): Yes/No	Reduction Rate (%)	UpFlow filter has acceptable treatability by TAPE: Yes/No
16-Jul-10	49.6	149	Yes	50 mg/L	15	Yes	90	Yes
28-Aug-10	51.7	85	No	20 mg/L	5	Yes	94	Yes
28-Oct-10	76.9	104	Yes	80%	22	No	79	No
2-Nov-10	73.7	72	No	20 mg/L	37	No	49	No
3-Nov-10	49.6	87	No	50 mg/L	19	Yes	78	Yes
11-Dec-10	36.3	131	Yes	50 mg/L	50	Yes	62	Yes
1-Jan-11	57.3	52	No	20 mg/L	17	Yes	67	Yes
25-Feb-11	43.3	27	No	50 mg/L	6	Yes	77	Yes
11-Apr-11	45.6	101	Yes	50%	69	No	32	No

Flow Weighted Influent SSC (mg/L) = 77.4

Flow Weighted Effluent SSC (mg/L) = 21.5

Flow Weighted SSC Reduction (%) = 72.2 (not including gross solids removals in the sump)

Neither Tables 47 nor 48 include directly the additional material captured in the sump that is not captured by the automatic samplers. Automatic samplers are not effective in capturing larger particulates found in stormwater sampled at sources areas or at inlets (Clark, et al 2009). As noted in the previous chapter, the sump material was measured and sampled. The material >250 μm in the sump was used to replace this size range measured in the automatic influent sampler, as the automatic samplers had relatively poor recoveries for these larger particles. These data were not included in Tables 47 and 48 because they cannot be separated by individual events, but can only be used when determining performance by the sum of loads method that uses all events monitored during the evaluation period.

Table 49 summarizes the upflow filter performance evaluation by SSC including all of the 20 monitored events (not excluding unqualified events by the TAPE criteria described above). Fifteen of the 20 events in the table indicated acceptable treatability of the upflow filter.

Table 49. All Events: UpFlow Filter Performance Evaluation by SSC (excluding sump gross solids samples)

Event Date	Mean Particle Size (µm)	Influent SSC (mg/L)	Influent SSC 100~200 mg/L: Yes/No	Applicable Performance Criteria (% removal or effluent conc)	Effluent SSC (mg/L)	Effluent SSC less than 20 mg/L (or 50 mg/L for less than 50 mean micron): Yes/No	Reduction Rate (%)	UpFlow filter has acceptable treatability by TAPE: Yes/No
16-Jul-10	49.6	148.6	Yes	50 mg/L	14.7	Yes	90.1	Yes
*14-Aug-10	51.7	140.6	Yes	80%	7.6	Yes	94.6	Yes
28-Aug-10	51.7	85.3	No	20 mg/L	4.8	Yes	94.4	Yes
*26-Sep-10	49.6	53.6	No	50 mg/L	10.0	Yes	81.3	Yes
*12-Oct-10	48.3	59.0	No	50 mg/L	18.0	Yes	69.5	Yes
*26-Oct-10	54.4	94.5	No	20 mg/L	21.7	No	77.0	No
28-Oct-10	76.9	103.6	Yes	80%	21.7	No	79.1	No
2-Nov-10	73.7	72.0	No	20 mg/L	37.0	No	48.6	No
3-Nov-10	49.6	87.0	No	50 mg/L	19.0	Yes	78.2	Yes
11-Dec-10	36.3	131.0	Yes	50 mg/L	50.3	Yes	61.6	Yes
*25-Dec-10	54.2	115.0	Yes	80%	40.6	No	64.7	No
*31-Dec-10	47.7	80.0	No	50 mg/L	29.0	Yes	63.8	Yes
1-Jan-11	57.3	52.0	No	20 mg/L	17.0	Yes	67.3	Yes

*10- Jan- 11	52.2	29.0	No	20 mg/L	6.0	Yes	79.3	Yes
*25- Jan- 11	47.4	43.0	No	50 mg/L	17.9	Yes	58.4	Yes
25- Feb- 11	43.3	27.0	No	50 mg/L	6.3	Yes	76.7	Yes
*4- Mar- 11	32.2	33.0	No	50 mg/L	11.6	Yes	64.8	Yes
*28- Mar- 11	29.7	24.0	No	50 mg/L	21.1	Yes	12.1	Yes
*29- Mar- 11	26.8	37.0	No	50 mg/L	11.6	Yes	68.6	Yes
11- Apr- 11	45.6	101.0	Yes	50%	69.0	No	31.7	No

Flow Weighted Influent SSC (mg/L) = 74.2

Flow Weighted Effluent SSC (mg/L) = 20.3

Flow Weighted SSC Reduction (%) = 72.7 (not including gross solids removals in the sump)

* Data is not qualified by the TAPE criteria described above

As shown in Tables 47 and 48, the TSS and SSC evaluations resulted in slightly different findings regarding the removal rates and effluent sediment concentrations. Table 49 examined all of the monitored events, and 15 of the 20 showed the necessary treatment level for the performance of the upflow filter.

Logistic regression analysis was conducted to see if the TAPE qualification criteria have a significant impact for assessing the acceptable treatability of the upflow filter. Detailed analyses were included in Appendix J. The model uses the following six factors:

Subsamples: subsample numbers

TAPE: if the event qualified by TAPE “yes=1” if not “no=0”

SSC Influent (mg/L): SSC influent concentration

Reduction (%): percentage of SSC reduction for influent and effluent

Peak Intensity (in/hr): peak intensity of the event

Duration (hr): duration of the storm

Pearson chi-square, deviance, and Hosmer and Lemeshow goodness of fit indicate that the logistic response function is appropriate and the odd ratio of each factor shows that subsample number and percentage reductions of SSC were 19 and 16%, respectively, higher contribution of determining the acceptable treatability of the upflow filter. In contrast, the TAPE qualification criteria was not significant ($p=0.963$) for the model in affecting the resulting performance calculations. In another words, the acceptable treatability of the upflow filter was not significantly affected by the TAPE qualification criteria in this example, while the TAPE qualification criteria did affect the results. Many other models were also tested with similar results.

As TAPE was designed for an area having long and less intense storms, the short and more intense storm characteristics at the Bama Belle site makes it difficult to apply some of the criteria described in the TAPE protocol. The protocol should be adjusted according to the rain characteristics for an area and should include all events that may occur, as they all contribute stormwater pollutants.

6.2 Technology Acceptance Reciprocity Partnership (TARP) Protocol Analysis

The TARP protocol is developed for the purpose of evaluating both structural and nonstructural stormwater management technologies which can remove contaminants such as suspended or dissolved pollutants from collected stormwater through physical and chemical processes including settling, media-filtering, iron-exchange, carbon adsorption, and precipitation (TARP, 2001). Multiple states agreed to TARP, including California, Massachusetts, Maryland, New Jersey, Pennsylvania, and Virginia. As New Jersey is one of the partners of TARP, the NJCAT protocol is mainly designed for verification in New Jersey by applying the TARP protocol.

Table 50. TARP Protocol Criteria

Criteria	
Applicable States	California Massachusetts Maryland New Jersey Pennsylvania Virginia
Minimum Number of Events	15-20
Minimum Storm Depth (inches)	0.1
Minimum Sub-Sample Numbers per Event	5-10
Minimum Dry Duration (hours)	6 hours

6.2.1 TARP Criteria Verification for each Sample Event

Event evaluations were conducted in order to identify the qualified events according to the TARP event criteria.

Table 51. Monitored Rain Qualification Verification for TARP Protocol

Event Date	Rain depth (inch) : >0.1	Subsamples (#) : >5	Dry Period (hours) : >6	Qualify? Yes or No (Reason)
16-Jul-10	0.78	11	>6	Yes
14-Aug-10	0.81	9	>6	Yes
28-Aug-10	1.2	16	>6	Yes
26-Sep-10	0.26	8	>6	Yes
12-Oct-10	0.11	5	>6	Yes
26-Oct-10	0.72	8	>6	Yes
28-Oct-10	0.51	12	>6	Yes
2-Nov-10	0.8	15	>6	Yes
3-Nov-10	0.7	14	>6	Yes
11-Dec-10	0.72	11	>6	Yes
25-Dec-10	0.13	5	>6	Yes
31-Dec-10	0.55	7	>6	Yes
1-Jan-11	1.48	30	>6	Yes
10-Jan-11	0.22	5	>6	Yes
25-Jan-11	0.35	7	>6	Yes
25-Feb-11	0.88	16	>6	Yes
4-Mar-11	0.84	11	>6	Yes
28-Mar-11	0.21	5	>6	Yes
29-Mar-11	0.25	4	>6	No (subsample)
11-Apr-11	0.81	6	>6	Yes

Table 51 indicates that 19 of the 20 storms were acceptable according to the TARP criteria, including those which were excluded from the TAPE evaluation (due to some of the events not meeting the subsample number criterion). Only one storm event was excluded due to the subsample number criterion. Unlike the TAPE protocol which requires relatively larger storms having longer rain durations and larger rain depths, the TARP protocol accepted much smaller rain events as a qualified event. The Bama Belle site was a relatively small, mostly paved, site. The preliminary grab sample monitoring and the continuous influent water quality sonde data showed a significant “first flush” effect with gradually decreasing (going to a relatively constant concentration for a long event) influent turbidity data. As the sample was collected in the single composite container, longer storm events likely reduced the first flush concentration

due to the dilution of large amounts of cleaner samples collected during the later periods of the event. The TAPE protocol was developed to consider the longer and larger rain events in Washington compared to the TARP protocols that also accept much smaller rains. The differences in qualified storm criteria for TAPE and TARP were due to the types of runoff events in the areas where these criteria were developed.

6.2.2 *TARP Qualified Events and UpFlow Filter Performance*

Unlike the TAPE protocol, the TARP protocol does not specify the minimum removal of specific constituents as an acceptance performance criteria for the emerging technologies. The TARP protocol is intended to evaluate the overall removal efficiency of a broad list of pollutants including sediments, nutrients, heavy metals, and bacteria (TARP, 2001). TARP requires TSS and SSC as a minimum, and recommends other parameters as a support of overall performance claims. Many parameters were analyzed during the upflow filter field monitoring tests and Table 52 summarizes the observed performance.

Table 52. Overall Monitored Performance of the UpFlow Filter (excluding gross solids captured in the sump)

	Average influent concentration (all mg/L, except for bacteria that are #/100mL, turbidity that is NTU, and metals that are µg/L, conductivity that is µs/cm (and COV))	Average effluent concentration (all mg/L, except for bacteria that are #/100mL, turbidity that is NTU, and metals that are µg/L, conductivity that is µs/cm (and COV))	Calculated percentage removal based on average influent and average effluent concentrations of individual event pairs (median of individual sample pair reductions)	Probability that influent ≠ effluent (nonparametric sign test) (significant reduction at 95% level? “S=significant” or “N=not significant”)
TSS	62.3 (0.5)	20.5 (0.7)	66.0 (70.9)	>99% (S)
SSC	75.8 (0.5)	21.7 (0.8)	68.1 (76.4)	>99% (S)
TDS	112.8 (0.5)	66.9 (0.5)	34.8 (31.6)	>99% (S)
Conductivity	124.0 (0.8)	85.9 (0.5)	23.2 (26.5)	>99% (S)
Turbidity	18.2 (0.7)	7.4 (0.5)	50.3 (54.0)	>99% (S)
Total COD	42.1 (0.9)	24.3 (1.0)	43.4 (42.9)	>99% (S)
Dissolved COD	25.2 (1.0)	16.3 (1.2)	41.5 (36.4)	>99% (S)
Total Phosphorus	1.28 (0.4)	0.97 (0.5)	21.6 (30.5)	>99% (S)
Dissolved Orthophosphate	0.64 (0.6)	0.50 (0.5)	21.1 (9.3)	>99% (S)
Dissolved Total Phosphorus	0.62 (0.1)	0.56 (0.1)	10.2 (6.6)	97% (S)
Ammonia	0.09 (0.8)	0.04 (0.8)	52.4 (62.5)	>99% (S)
Nitrate	0.9 (0.5)	0.6 (0.3)	27.8 (18.8)	>99% (S)
Total Nitrogen	3.4 (0.3)	1.8 (0.4)	45.9 (33.3)	99% (S)
Dissolve Nitrogen	2.1 (0.3)	1.0 (0.6)	57.9 (50.0)	81% (N)
Total Zinc	0.08 (0.4)	BDL	>74.2 (>77.8)	NA
Dissolved Zinc	0.075 (0.1)	0.03 (NA)	73.3 (60.0)	NA
Total Cadmium	BDL	BDL	NA	NA
Dissolved Cadmium	BDL	BDL	NA	NA
Total Chromium	BDL	BDL	NA	NA
Dissolved Chromium	BDL	BDL	NA	NA
Total Copper	0.08 (1.2)	0.04 (0.7)	50.0 (-14.3)	NA
Dissolved Copper	0.05 (0.6)	0.05 (NA)	0.0 (NA)	NA
Total Lead	0.012 (0.1)	BDL	>58.3	NA
Dissolved Lead	BDL	BDL	NA	NA
E-Coli	6620 (1.7)	3091 (1.8)	54.3 (66.8)	>99% (S)
Enterococci	7368 (0.8)	4825 (1.0)	42.1 (59.4)	>99% (S)

Table 52 values do not include the additional large material captured in the sump but that was not collected by the autosamplers. The earlier discussion of the performance of the UpFlo Filter during the full-scale Bama Belle tests indicated that the sump material significantly increased the removals of the particulate-bound pollutants.

6.3 New Jersey Corporation for Advanced Technology (NJCAT) Protocol Analysis

For stormwater technologies, NJCAT requires innovative technology to be tested and verified using their modification to the TARP protocol as New Jersey is one the major participants for the TARP protocol. Thus, the verification criteria, analysis results, and performance evaluation process is the same with the above described TARP protocol.

6.4 Environmental Technology Verification Program (ETV) Analysis

One of the main differences of ETV with other protocols is that ETV has been used to supports the development of verification systems in other countries, in addition to the U.S. program. Table 53 summarizes the ETV protocol criteria.

Table 53. ETV Protocol Criteria

Criteria	
Applicable State	U.S. and several other countries
Minimum Number of Events	15
Minimum Storm Depth (inches)	0.2
Minimum Sub-Samples per Event	5
Minimum Dry Duration (hours)	6 hours

6.4.1 ETV Criteria Verification for each Sample Event

Qualified events were determined using the ETV protocol criteria. ETV required a rain depth of at least 0.2 inches (the largest minimum rain among the protocols). Other criteria are similar to the TARP protocol. Table 54 describes the qualified storms based on the ETV protocol.

Table 54. Sample Qualification Verification for ETV Protocol

Event Date	Rain depth (inch) : >0.2	Subsamples (#) : >5	Storm Duration (hours) : >6	Qualify? Yes or No (Reason)
16-Jul-10	0.78	11	>6	Yes
14-Aug-10	0.81	9	>6	Yes
28-Aug-10	1.2	16	>6	Yes
26-Sep-10	0.26	8	>6	Yes
12-Oct-10	0.11	5	>6	Yes
26-Oct-10	0.72	8	>6	Yes
28-Oct-10	0.51	12	>6	Yes
2-Nov-10	0.8	15	>6	Yes
3-Nov-10	0.7	14	>6	Yes
11-Dec-10	0.72	11	>6	Yes
25-Dec-10	0.13	5	>6	No (rain)
31-Dec-10	0.55	7	>6	Yes
1-Jan-11	1.48	30	>6	Yes
10-Jan-11	0.22	5	>6	Yes
25-Jan-11	0.35	7	>6	Yes
25-Feb-11	0.88	16	>6	Yes
4-Mar-11	0.84	11	>6	Yes
28-Mar-11	0.21	5	>6	Yes
29-Mar-11	0.25	4	>6	No (subsample)
11-Apr-11	0.81	6	>6	Yes

As indicated above table, two of the 20 storm events were excluded according to the ETV requirement due to the rain depth being less than the required 0.20 inches or the subsample count being less than 5.

6.4.2 *ETV Qualified Events and UpFlow Filter Performance*

Similar to the TARP protocol, the ETV protocol does not specify a removal requirement for specific parameters as acceptance of the technology. The ETV protocol requires the reduction of at least one of the pollutants in the five categories of sediments, nutrients, metals, petroleum hydrocarbons, and bacteria. No primary parameters are needed unless there is a reduction for at least one parameter in each of the five categories. Also ETV protocol is the only protocol that recommends testing for turbidity, which can be used as an indicator for sediment concentrations. As the ETV does not specify specific constituents as the primary parameter for the evaluation of the technology, the performance claim report would be similar to the TARP protocol performance data describe in Table 52.

6.5 Summary

As the different protocols apply somewhat different criteria for the constituents and qualified storm selection, the evaluation results of the same technology may vary. As described above, the TAPE protocol excluded more than half of the storm events monitored during the monitoring period mostly due to the subsample number criterion, and few samples due to the storm size criterion. In contrast, the TARP protocol allowed 19 of the 20 storms to be considered, and the ETV protocol rejected only two events due to the rain depth being too small or not enough subsample numbers. Excluding large numbers of actual events can result in biased results as the monitored events then are no longer representative of the total rain period. In addition, the TAPE protocol strictly requires the removal of the TSS as a primary constituent to a specific level. The other protocols are more flexible and are only intended to ensure the accuracy of the manufacture's claims. At the Baba Belle site, the majority of the storm events were

relatively large depth with high intensities for a short period, but still some of the events were small and excluded by all of the protocols.

The TAPE protocol eliminated 11 of the 20 events, resulting in only 9 acceptable storm events under their criteria. However, most of the excluded events (9 of the 11 excluded events) still supported the high performance levels specified by their criteria.

Under the TARP protocol evaluation, 19 of the 20 monitored events were qualified. Only one event was eliminated due to the lack of subsamples. Compared with the TAPE protocol, the TARP protocol allowed much smaller rain events to be listed as qualified events, while the TAPE protocol requires relatively larger storms having longer rain durations and larger rain depths, likely resulting in biased performance results.

The ETV protocol resulted in 18 of the 20 events to be qualified; two events were excluded due to the rain depth or subsample criteria.

6.6 Recommendations and Proposed Protocol Framework

There are several recommendations and discussions for the development of a new protocol framework from the findings in the previous chapters, as listed in the following:

1. Monitor all events in the study period, with no exclusions (the study period should be for a complete wet season, at least). Influent sampling must be a total flow sample (cascading water), as well as the effluent sample. The effluent sample must also include any bypass flows.
2. Evaluate performance using sum of loads for the complete evaluation period.
3. Conduct a mass balance calculation of the device to verify sampling accuracy (and to incorporate gross solids as part of the influent).

4. Use flow-weighted composite sampling with about 3 programs for small, typical, and large events to attempt to capture at least 5 to 10 subsamples per event, and to represent most of the flow durations.
5. Analyze data and report performance as a function of rain size, influent concentrations, and particle size.
6. Monitoring results and report must describe maintenance issues (clogging, bypassing, etc.).

Thus, considering all the above recommendations with findings from previous chapters, the new protocol framework should consider following.

1. Initial Field Sampling: Existing protocols do not require any initial field sampling to verify site conditions. However, the collection of samples prior to the selection of the test site is highly recommended in order to compare the site conditions to the monitoring objectives. The additional cost is usually more than offset compared to the cost of a monitoring program that does not represent local critical conditions. In this project total of 7 initial samples were collected during October 2007 to April 2008 and the pollutant concentrations were not vary greatly between events, with COV values less than 0.5 as shown in Section 3.9.6. When compared with the national stormwater quality data, Bama Belle site had a similar concentrations for the solids, COD, and nutrients while the copper and zinc values were only about 1/5 of the average concentrations reported nationally as shown in Section 2.7. Initial sampling enables to identify the local site conditions compared

to the national quality data and it also determines the unique treatment objectives as described above.

2. Constituents Selection: TAPE requires TSS as a primary pollutant and TARP requires TSS and SSC as a minimum analysis, while ETV does not have specific criteria for constituents. Some of the local protocols in Maine, New York, Virginia, Wisconsin, and Minnesota, are addressing the removal of total phosphorus (TP). As discussed in Section 2.5, successful stormwater control technologies should be able to remove a broad range of pollutants, including debris and floatable materials, over a wide range of flows. Thus, pollutant reduction criteria should not be limited to only TSS or TP reductions which may not be suitably comprehensive for all areas. It is recommended to expand the evaluations to a broader range of likely contaminants of local interest. Some treatment technologies can be modified to target narrower ranges of contaminants, especially media filtration when sorption and ion exchange are the main treatment mechanisms and are relatively specific for the contaminants that can be controlled. In this project constituents were selected based on the TAPE and TARP protocols as well as the data obtained in the initial sampling as described in Section 3.12.2. Constituents selection should be determined based on the local treatment objectives using the insight obtained from the initial sampling data and compare it to the national quality data. If the particular pollutants concentrations are significantly larger than the national data, these constituents can be selected as a primary pollutants. Bama Belle site had a lower concentration for copper and zinc, so these pollutants are not the primary while the site had broad stormwater

pollutants including solids, nutrients, and COD therefore those pollutants can be selected as a primary. Then the treatment device required to remove a broad range of stormwater pollutants, so the Up-Flo[®] Filter was appropriate. If the site had different pollutant characteristics, for instance, only high influent concentrations in the dissolved nutrients, different treatment objectives may be applied.

3. **Applicable State:** All of the existing protocols are based on political jurisdictions. As described in Section 4.6 and by many researchers, land use has a significant effect on pollutant characteristics, along with geographical location (to a lesser extent). An improved protocol framework therefore should consider the differences in land use and associated stormwater characteristics, rather than the state political jurisdictions alone. It is also important to analyze site characteristics and identify local problems that are to be addressed with the treatment system. In this project Bama Belle site data was compared with the SBIR II sampling location, the NSQD Alabama, and the NSQD Rain Zone 3. Bama Belle sediments and precipitation data were similar to the NSQD Alabama as well as the NSQD Rain Zone 3 as described in Section 4.6. As the Bama Belle site could represent the typical trend in the national data, the new protocol can expand to the broader area.
4. **Minimum Number of Storms:** Existing protocols require from 12 to 35 qualified storms, as a minimum. As described in Section 4.7, sampling theory provides a logical sample size method for different data quality objectives. The objective of this component in an evaluation protocol is to ensure that there are sufficient data to determine if a statistically significant difference exists between influent

(untreated) and effluent (treated) pollutant concentrations, at a reasonable treatment rate. Favorable sampling numbers may be estimated during the initial field sampling efforts by evaluating the variation of the sample. In any case, it is recommended to monitor all events occurring in the study period and the study period should be for the complete wet season. In this project, several different constituents was tested to determine the minimum sample sizes. Based on the SSC variation, 3 to 7 samples were required while turbidity variability required 8 to 12 sample sizes. *E. coli* had highest variation compared with any other constituents and required 45 to 78 sample sizes as described in Section 4.7.5. Selection of the constituents should be based on the local treatment objectives as described above and it also relate to the calculation of the minimum sample sizes.

5. Minimum Rain Duration: The TAPE protocol requires at least an hour of rain duration, while other protocols do not have a minimum rain duration criteria. As discussed in Section 4.8, runoff volume obviously increases as the precipitation depth increased, but for the Bama Belle site, the rain duration had a much smaller effect on the runoff volume. It is recommended to use a locally calibrated stormwater model to estimate the minimum rain depth and storm duration criteria before the site is selected for monitoring, to ensure that runoff will be available for sampling. In this project, rain depth (inches) vs. runoff volume (gallons) model was developed using the actual event data as well as WinSLAMM. The model indicated that WinSLAMM could accurately represent the actual data as described in Section 4.8. As from the model the Bama Belle site required approximately 0.05 inches of rain (500 gallons of runoff) to generate the

sampleable volume of runoff. These model are easily developed for any locations and it provides a useful insight for the storm characteristics.

6. Minimum Number of Subsamples: Existing protocols require at least 5 to 10 subsamples per monitored event in an attempt to represent the complete rain period. As described in Section 4.9, flow-weighted composite sample can represent the characteristics of the entire storm relatively well. The existing protocols eliminated some of the Bama Belle events due to the subsample criteria. It is recommended to use about 3 different programs for small, typical, and large events to attempt to capture at least 5 to 10 subsamples per event. Local weather forecast can be used to adjust the sampling program before the storm.
7. Minimum Time between Events: Most of the existing protocols apply the six hour dry period requirement between each monitored event. As shown with the event data in Section 4.10, there were few differences in pollutant levels for events with shorter antecedent dry periods vs. longer dry periods. In fact, the TSS and *E. coli* levels were actually larger during some events that had a much shorter antecedent dry period. The proposed protocol should modify the six hours criteria based on site conditions to ensure that all representative events are sampled, as long as the event hydrographs can be cleanly separated. The continuous water quality monitoring sonde also indicates that the turbidity of the runoff is likely correlated with the intensity of the rain. These data can also be used to separate the storms into different monitoring periods.

CHAPTER 7

7: QUALITY ASSURANCE PROJECT PLAN AND RESULTS

The quality assurance project plan (QAPP) was described in Chapter 3. This chapter verifies that the project was conducted with acceptable quality and accuracy by meeting the data quality objectives presented in the QAPP.

7.1 Data Quality Verification

The objective of QA/QC is to ensure that valid methods and procedures were used during sampling and analysis so that the data obtained are useful for the verification of the technology. Several Data Quality Indicators (DQIs) have been identified as key factors in assessing the quality of the data and in supporting the verification process. Precision was evaluated from the analysis of field and laboratory duplicates. As an example, field duplicates were collected for both influent and effluent samples.

Accuracy is defined for water quality analyses as the difference between the measured value, or calculated sample value, and the true value of the sample. Comparability was achieved by using consistent and standardized sampling and analytical methods. Representativeness is the degree to which data accurately and precisely represent a characteristic population, parameter at a sampling point, a process condition, or an environmental condition. Completeness is a measure

of the number of valid samples and measurements that were obtained during a test period compared to the original goal.

7.1.1 *Controlled Test Verification*

The controlled performance monitoring was conducted at the Riverwalk parking lot near the Bama Belle in late summer of 2009. Duplicate turbidity samples were used to measure the precision of the monitoring data. The standard deviation (SD) and relative percent difference values (RPD) were calculated for each data set. As an example, Tables 55 and 56 show the duplicate turbidity analysis results for the sand media and mixed media tests for each flow rate and different sediment concentrations.

Table 55. Turbidity Duplicate Analysis for Sand Media Controlled Flow Test

(mg/L)	25 gal/min				75 gal/min				150 gal/min			
	1.	2.	SD	RPD	1.	2.	SD	RPD	1.	2.	SD	RPD
50	27.9	27.1	0.6	2.9	12.8	13.1	0.2	2.3	8.39	8.53	0.1	1.7
100	19.4	20.7	0.9	6.5	11.8	11.5	0.2	2.6	15.5	14.4	0.8	7.4
250	53.7	54.4	0.5	1.3	21.9	22.8	0.6	4.0	40	39.2	0.6	2.0
500	49.5	42.9	4.7	14.3	46.3	44.2	1.5	4.6	60.3	63.2	2.1	4.7

Table 56. Turbidity Duplicate Analysis for Mixed Media Controlled Flow Test

(mg/L)	25 gal/min				75 gal/min				150 gal/min			
	1.	2.	SD	RPD	1.	2.	SD	RPD	1.	2.	SD	RPD
50	17.3	22.3	3.5	25.3	19.3	18.5	0.6	4.2	17.2	17.6	0.3	2.3
100	15.8	15.5	0.2	1.9	19.4	17.3	1.5	11.4	18.9	20.4	1.1	7.6
250	19.4	19.7	0.2	1.5	27.6	30.9	2.3	11.3	41.9	41.8	0.1	0.2
500	27.9	25	2.1	11.0	49.4	50.1	0.5	1.4	60.6	67.2	4.7	10.3

Tables 55 and 56 show that the highly repeatable turbidity data having relatively small standard deviation (SD) values and most of the relative percent differences (RPD) are less than 10%, however; one data value set (for the 25 gal/min flow rate and 50 mg/L sediment concentration) exceeded the RPD goal of 15%. All of the analyses were conducted at the University of Alabama Civil, Construction, and Environmental Engineering laboratory. A total of 8 separate controlled experiments were conducted as part of the QA/QC program. Total solids, total suspended sediment (SSC), total dissolved solids (by difference), and particle size distribution (PSD) analyses were carried out for each sample and its duplicate. A total of 180 samples (with 90 duplicate) were analyzed during the controlled tests.

7.1.2 *Field Test Verification*

Field monitoring under the actual storm events started during mid-summer 2010. As stated above, the analyses of the field duplicates were conducted two times in order to satisfy the specified frequency of one duplicate for every ten events analyzed. Duplicate analyses were also randomly conducted with selected samples. The first duplicate analysis was conducted at the beginning of the monitoring period (September 26, 2010) and the second analysis was conducted approximately in the middle of the monitoring period (February 25, 2011). Duplicate samples (approximately two for each one liter sample bottle) were obtained from the single composite container using the cone splitter. Then the one liter sample was separated to ten approximately 100 mL small bottles in order to test in different constituents. Table 57 shows the first duplicate analysis set conducted with samples from the September 26, 2010 event. Most of the constituents had a relatively small standard deviation (SD) and relative percent difference (RPD) value, except for the bacteria data which were traditionally more variable than other stormwater

constituents. Other constituents with high RPD values were those that were very low in concentration, especially for the effluent data (such as for ammonia).

Table 57. September 26, 2010 Event Duplicate Analysis Result

	Influent	Duplicate	SD	RPD	Effluent	Duplicate	SD	RPD
TSS (mg/L)	55	58	2.1	5.3	8	10	1.4	22.2
SSC (mg/L)	53.6	55	1.0	2.6	10	10	0.0	0.0
pH	6.58	6.58	0.0	0.0	6.83	6.82	0.0	0.1
Conductivity (μ s/cm)	106.3	105.8	0.4	0.5	96	96.5	0.4	0.5
Turbidity (NTU)	21.2	20.8	0.3	1.9	9.45	9.48	0.0	0.3
Total COD (mg/L)	72	74	1.4	2.7	49	47	1.4	4.2
Dissolved COD (mg/L)	28	31	2.1	10.2	26	26	0.0	0.0
Total Phosphorus (mg/L)	1.15	1.12	0.0	2.6	0.86	0.81	0.0	6.0
Reactive Phosphorus (mg/L)	0.57	0.53	0.0	7.3	0.55	0.49	0.0	11.5
Ammonia (mg/L)	0.08	0.08	0.0	0.0	0.01	0.02	0.0	66.7
Nitrate (mg/L)	0.8	0.8	0.0	0.0	0.7	0.6	0.1	15.4
Total Nitrogen (mg/L)	3	3	0.0	0.0	2	2	0.0	0.0
Dissolve Nitrogen (mg/L)	2	2	0.0	0.0	1	1	0.0	0.0
E-Coli (mpn)	4170	6780	1846	47.7	840	1220	269	36.9
Enterococci (mpn)	2230	3210	693	36.0	1180	1550	262	27.1
Total Zn (μ g/L)	0.09	0.09	0.0	0.0	BDL	BDL	NA	NA
Dissolved Zn (μ g/L)	0.08	0.08	0.0	0.0	BDL	BDL	NA	NA
Total Cd (μ g/L)	BDL	BDL	NA	NA	BDL	BDL	NA	NA
Dissolved Cd (μ g/L)	BDL	BDL	NA	NA	BDL	BDL	NA	NA
Total Cr (μ g/L)	BDL	BDL	NA	NA	BDL	BDL	NA	NA
Dissolved Cr (μ g/L)	BDL	BDL	NA	NA	BDL	BDL	NA	NA
Total Cu (μ g/L)	0.21	0.21	0.0	0.0	0.06	0.06	0.0	0.0
Dissolved Cu (μ g/L)	0.08	0.08	0.0	0.0	0.05	0.05	0.0	0.0
Total Pb (μ g/L)	BDL	BDL	NA	NA	BDL	BDL	NA	NA
Dissolved Pb (μ g/L)	BDL	BDL	NA	NA	BDL	BDL	NA	NA

Table 58 shows the results from the duplicate analyses conducted for the February 25, 2011 event. Similar trends were seen for this event, with most of the constituents having small standard deviation (SD) and relative percent difference (RPD) values, whereas the bacteria data and constituents at low concentrations (COD in this case) having higher SD and RPD values.

Table 58. February 25, 2011 Event Duplicate Analysis Result

	Influent	Duplicate	SD	RPD	Effluent	Duplicate	SD	RPD
TSS (mg/L)	15	13	1.4	14.3	7	5	1.4	33.3
SSC (mg/L)	27	28.5	1.1	5.4	6.3	7.1	0.6	11.9
pH	7.22	7.22	0.0	0.0	7.23	7.21	0.0	0.3
Conductivity (μ s/cm)	50.7	48.9	1.3	3.6	37.4	35.2	1.6	6.1
Turbidity (NTU)	8.9	8.8	0.1	1.1	5.9	5.81	0.1	1.5
Total COD (mg/L)	3	3	0.0	0.0	2	1	0.7	66.7
Dissolved COD (mg/L)	6	5	0.7	18.2	3	2	0.7	40.0
Total Phosphorus (mg/L)	0.71	0.68	0.0	4.3	0.62	0.63	0.0	1.6
Reactive Phosphorus (mg/L)	0.38	0.35	0.0	8.2	0.3	0.28	0.0	6.9
Ammonia (mg/L)	0.02	0.02	0.0	0.0	0.02	0.02	0.0	0.0
Nitrate (mg/L)	0.5	0.6	0.1	18.2	0.4	0.4	0.0	0.0
Total Nitrogen (mg/L)	3	3	0.0	0.0	2	2	0.0	0.0
Dissolve Nitrogen (mg/L)	2	2	0.0	0.0	1	1	0.0	0.0
E-Coli (mpn)	1090	1550	325.3	34.8	620	510	77.8	19.5
Enterococci (mpn)	15530	16100	403.1	3.6	10170	12450	1612.2	20.2
Total Zn (μ g/L)	BDL	BDL	NA	NA	BDL	BDL	NA	NA
Dissolved Zn (μ g/L)	BDL	BDL	NA	NA	BDL	BDL	NA	NA
Total Cd (μ g/L)	BDL	BDL	NA	NA	BDL	BDL	NA	NA
Dissolved Cd (μ g/L)	BDL	BDL	NA	NA	BDL	BDL	NA	NA
Total Cr (μ g/L)	BDL	BDL	NA	NA	BDL	BDL	NA	NA
Dissolved Cr (μ g/L)	BDL	BDL	NA	NA	BDL	BDL	NA	NA
Total Cu (μ g/L)	BDL	BDL	NA	NA	BDL	BDL	NA	NA
Dissolved Cu	BDL	BDL	NA	NA	BDL	BDL	NA	NA
Total Pb (μ g/L)	BDL	BDL	NA	NA	BDL	BDL	NA	NA
Dissolved Pb (μ g/L)	BDL	BDL	NA	NA	BDL	BDL	NA	NA

7.2 Analytical Methods Verification

All analysis were conducted using EPA, or other published methods including ASTM and Standard Method, as well as the approved IDEXX methods for the bacteria analyses, as shown on Table 59. All of these analyses were conducted in the environmental engineering laboratories of the Department of Civil, Construction, and Environmental Engineering at the University of Alabama, except for the metal analysis which were conducted by an outside laboratory (STILLBROOK Environmental Testing Laboratory, Inc. in Fairfield, AL) using EPA methods. Table 59 summarizes all the analytical methods used for the project and the detection limits or ranges for each constituent.

Table 59. Analytical Method Used

Constituents	Analytical Methods	Detection Limits/Ranges
SSC	ASTM D3977-97B	N.A.
TSS	EPA Method 160.2	N.A.
TS	EPA Method (by summation)	N.A.
TDS	EPA Method 160.2	N.A.
Cd (outside laboratory)	EPA-600/3-83	0.005 mg/L
Cr (outside laboratory)	EPA-600/3-83	0.02 mg/L
Cu (outside laboratory)	EPA-600/3-83	0.02 mg/L
Pb (outside laboratory)	EPA-600/3-83	0.005 mg/L
Zn (outside laboratory)	EPA-600/3-83	0.02 mg/L
COD	Hach 8000 (EPA Approved)	3 to 150 mg/L
Total P as PO ₄ ³⁻	Hach 8190 (Standard Method)	0.06 to 3.50 mg/L
Total Dissolved P as PO ₄ ³⁻	Hach 8190 (Standard Method)	0.06 to 3.50 mg/L
Dissolved Orthophosphate as PO ₄ ³⁻	Hach 8048 (Standard Method)	0.02 to 2.50 mg/L
Total/Dissolved N as N	Hach 10071 (EPA Approved)	0.5 to 25 mg/L
Ammonia as N	Hach 10023 (EPA Approved)	0.02 to 2.5 mg/L
Nitrate as NO ₃ ⁻ -N	Using Accu Vac Ampuls (EPA Approved)	0 to 5.0 mg/L
Bacteria	IDEXX Method	<1, 1-2419.6, >2419.6
Conductivity (laboratory)	EPA Method 120.6 (Standard Method 2510.B.)	0 to 199,900 μS
pH (laboratory)	EPA Method 150 (Standard Method 4500-H ⁺ .B.)	-2.00 to 19.99
Turbidity (laboratory)	EPA Method 180.1 (Standard Method 2130.B.)	1 to 4000 NTU
Temperature (laboratory)	EPA Method 170.1 (Standard Method 212)	-5.0 to 105.0 °C

7.3 Sample Collection Procedure Verification

Flow-weighted composite samples of the influent and effluent flows were collected simultaneously using programmable auto-samplers (ISCO model 6712). The influent samples were collected from a small influent sample tray that receives cascading influent water from the parking lot gutter, ensuring a completely mixed sample with no stratification of solids in the flowing water. This tray contains the intake of the auto-sampler and the continuous water quality

sonde (YSI model 6000). The effluent samples were obtained from the sampling chamber where the treated water flows from the outlet pipe of the device (including any bypassing water).

Similar to the influent sampling location, the effluent water cascaded into a small sampling tray that contained the auto-sampler intake and another continuous water quality sonde.

7.4 Completeness Verification for Each Protocol

Completeness was measured by comparing the number of valid data (qualified events that were sampled) with the specified requirements for each protocol. The completeness verification therefore varied depending on the different protocol criteria for selecting the qualified events, as described in Chapter 3. Table 60 summarizes the completeness calculation for each protocol.

Table 60. Completeness for Each Protocol

Protocols	Minimum number of events	Total monitored events	Qualified events	Completeness (%)
TAPE	12-35	20	9	75
TARP / NJCAT	15-20	20	19	100
ETV	15	20	18	100

TARP/NJCAT and ETV achieved 100% completeness, however; the qualified number of events was not sufficient for the TAPE protocol. The TAPE protocol requires more subsamples per event, and much larger and longer storms compared with the other protocols.

7.5 Field and Laboratory Blank Verification

Any sampling or analytical source of contamination was documented and minimized using field and laboratory blank samples on a regular basis. Two field and laboratory blanks were collected on site to evaluate contamination potential in the entire sampling process including all equipment (automatic sampler, sample-collection bottles, and splitters), filtering procedures, and analytical procedures. Field blank samples were collected using distilled water available at the University of Alabama laboratory. The water was pumped through the automatic sampler and processed and analyzed in the same manner as event samples were processed. Laboratory blank samples were also tested in the same method as event samples using the same distilled water at the University of Alabama laboratory. The first field and laboratory blank was taken on July 13, 2010 right after the final controlled flow test and prior to the first monitoring. The second field and laboratory blank was taken on December 29, 2010. Tables 61 and 62 summarize the field and laboratory blank data.

Table 61. July 13, 2010 Blank Analysis Result

Constituents	Field Blank		Laboratory Blank
	Inflow	Effluent	Data
SSC (mg/L)	0	0	0
TSS (mg/L)	0	0	0
TDS (mg/L)	6	3	0
pH	6.80	6.80	6.81
Conductivity ($\mu\text{s}/\text{cm}$)	5.11	4.50	4.15
Turbidity (NTU)	0.512	0.420	0.401
Total COD (mg/L)	0	0	0
Dissolved COD (mg/L)	0	0	0
Total Phosphorus (mg/L)	0	0	0
Reactive Phosphorus (mg/L)	0	0	0
Ammonia (mg/L)	0.00	0.00	0.00
Nitrate (mg/L)	0.1	0	0
Total Nitrogen (mg/L)	0	0	0
Dissolve Nitrogen (mg/L)	0	0	0
E-Coli (mpn)	<1	<1	<1
Enterococci (mpn)	<1	<1	<1
Total Zn ($\mu\text{g}/\text{L}$)	BDL	BDL	BDL
Dissolved Zn ($\mu\text{g}/\text{L}$)	BDL	BDL	BDL
Total Cd ($\mu\text{g}/\text{L}$)	BDL	BDL	BDL
Dissolved Cd ($\mu\text{g}/\text{L}$)	BDL	BDL	BDL
Total Cr ($\mu\text{g}/\text{L}$)	BDL	BDL	BDL
Dissolved Cr ($\mu\text{g}/\text{L}$)	BDL	BDL	BDL
Total Cu ($\mu\text{g}/\text{L}$)	BDL	BDL	BDL
Dissolved Cu	BDL	BDL	BDL
Total Pb ($\mu\text{g}/\text{L}$)	BDL	BDL	BDL
Dissolved Pb ($\mu\text{g}/\text{L}$)	BDL	BDL	BDL

Table 62. December 29, 2010 Blank Analysis Result

Constituents	Field Blank		Laboratory Blank
	Inflow	Effluent	Data
SSC (mg/L)	2	1	0
TSS (mg/L)	1	0	0
TDS (mg/L)	7	2	0
pH	6.81	6.83	6.81
Conductivity ($\mu\text{s}/\text{cm}$)	5.11	4.5	4.07
Turbidity (NTU)	0.525	0.47	0.411
Total COD (mg/L)	0	0	0
Dissolved COD (mg/L)	0	0	0
Total Phosphorus (mg/L)	0	0	0
Reactive Phosphorus (mg/L)	0.02	0.02	0.01
Ammonia (mg/L)	0	0	0
Nitrate (mg/L)	0.1	0.1	0
Total Nitrogen (mg/L)	0	0	0
Dissolve Nitrogen (mg/L)	0	0	0
E-Coli (mpn)	<1	<1	<1
Enterococci (mpn)	<1	<1	<1
Total Zn ($\mu\text{g}/\text{L}$)	BDL	BDL	BDL
Dissolved Zn ($\mu\text{g}/\text{L}$)	BDL	BDL	BDL
Total Cd ($\mu\text{g}/\text{L}$)	BDL	BDL	BDL
Dissolved Cd ($\mu\text{g}/\text{L}$)	BDL	BDL	BDL
Total Cr ($\mu\text{g}/\text{L}$)	BDL	BDL	BDL
Dissolved Cr ($\mu\text{g}/\text{L}$)	BDL	BDL	BDL
Total Cu ($\mu\text{g}/\text{L}$)	BDL	BDL	BDL
Dissolved Cu	BDL	BDL	BDL
Total Pb ($\mu\text{g}/\text{L}$)	BDL	BDL	BDL
Dissolved Pb ($\mu\text{g}/\text{L}$)	BDL	BDL	BDL

There was no significant contamination of sampling tube, collection bottles, and splitter as the field and laboratory blanks did not show significant increases in the pollutant concentrations. Small amount of sediments were observed outside of the intake instrument of the autosampler and the field blanks were taken without washing off these sediments. Small amounts of sediment as shown on the above tables may be caused by those “carried-over” sediments that were on the outside of the intake and not in the intake tube. This small amount of sediment

contamination was only seen on the December 29th blank samples and is not expected to have any measureable effect on the monitored data.

CHAPTER 8

8: CONCLUSIONS AND FINDINGS

Conclusion and findings of this research are presented in this chapter compared to each hypothesis and objectives included in the research proposal.

8.1 Hypothesis #1

“The development of a single testing and evaluation protocol framework is possible, based on, and improving, components of existing protocols. This framework is especially needed for critical source area treatment devices used in small drainage areas.”

Chapter 6 described the analyses conducted using the available data obtained during the various monitoring tests of the Up-Flo[®] Filter, applying the four main protocols in order to evaluate their similarities and differences. The four main protocols were all effective tools for the evaluation of stormwater performance, however; they need to be modified depending on local site conditions. For instance, applicable state protocol criteria should consider the regional storm characteristics rather than the state political jurisdictions. The storm event sampling criteria also needs to consider the variations of influent pollutant concentrations.

Some of the approaches were described in the TAPE (TAPE, 2002) and the Section 4.7 of this report. Section 6.6 described the proposed protocol framework considering the criteria of existing protocols and findings of this research. The development of a new evaluation protocol

framework is possible by improving the existing protocols with better understanding of the site conditions.

8.2 Hypothesis #2

“A single protocol framework can be used to relate pilot-scale to full-scale tests; and controlled tests to actual event tests. The benefits from different protocol components can be tested and verified by laboratory and field tests.”

Chapter 4 of this report compared previous bench-scale and pilot-scale test data of upflow filtration processes to the results of the full-scale tests. Testing under a varying range of scales and conditions for a single common device was needed in order to verify and improve the protocol framework with a consideration of scaling effect as well as the reliability of the device treatability under different circumstances. A desirable protocol would be able to measure performance in a lab-scale test and be able to accurately predict long-term performance under actual full-scale conditions for a vary flow rates and different pollutants. In the laboratory, influent concentrations were less variable compared with the effluent concentrations due to the controlled nature of the tests, however; during full-scale monitoring tests during actual rains, flows and influent pollutants were extremely variable depending on the storm conditions. In addition to the variation of influent and effluent concentrations, a laboratory setup is usually limited and it is difficult to simulate the actual storm runoff which carries many types of pollutants, as well as large amounts of debris and floatable materials over a wide range of flow rates. In order to verify the practical treatability of the device, it is necessary to monitor the performance of the technology under laboratory, controlled field, and the actual field setting. The desired protocol can then relate the scaling and varying conditions of evaluation process.

8.3 Objective #1

“Verify existing protocols and establish guidance to create a protocol framework useful under a wide range of conditions and scales for in-drain treatment technologies.”

Chapter 6 verified and compared existing protocols in order to establish a robust protocol framework. Section 6.6 describes the proposed protocol framework considering the criteria of existing protocols and findings of the research. Existing protocols are useful tools to establish monitoring objectives. However, they need to be modified based on the unique site conditions and local objectives, especially if these local conditions are significantly different from historical datasets. As noted previously, pre-monitoring samples are useful in order to understand the general characteristics of storms and constituents of interest at the monitoring site. Examining other related treatment technologies is also useful when developing or evaluating a new treatment device. The Up-Flo[®] Filter is a small version of the Multi-Chambered Treatment Train (MCTT) which includes a several treatment processes, including an initial grit chamber. Followed by a settling chamber (the sump in the upflow filter) and a final filtration/sorption/ion exchange chamber (media for the upflow) (Pitt et al., 1999). The Up-Flo[®] Filter has a much greater treatment flow rate as compared to the MCTT and therefore can be established in many more locations. Many of the current in-drain type stormwater treatment devices contain at least one of the settling or filtering treatment processes, the upflow filter test results and the evaluation processes are not limited to only the upflow filter, but they can easily be applied to other types of in-drain treatment technologies.

8.4 Objective #2

“Verify that the upflow filtration process is a suitable in-drain treatment technology for stormwater treatment under a wide range of site and hydraulic conditions.”

Chapter 4 described the multi-scale evaluations of the upflow filter and Chapter 5 described the performance of the full-scale upflow filter obtained during the controlled tests and under actual storm events. Upflow filtration is especially effective for pollutants associated with particulate matter, and less efficient for removing dissolved constituents. These results were constant for all evaluation processes from the bench-scale to the full-scale and the field monitoring under actual storms and the controlled test. The full-scale and SBIR II test results indicated that the upflow filter produced similar effluent particle size distributions and nearly constant effluent concentrations for many of the pollutants under different scale setups and varying flows and sediment characteristics. The upflow filter had reliable performance throughout the project evaluation phases and is a suitable in-drain treatment technology for the stormwater under a wide range of site and hydraulic conditions.

The removal rates were greater when the influent concentrations were largest, and less when the influent concentrations were lower. Also, the upflow filter was seen to have degraded performance with time, indicating that filter breakthrough was occurring before the end of the evaluation period. It is likely that the filter should receive maintenance (replacement of media bags and cleaning out of the sump) after about 20 inches of accumulative rainfall. The bypasses did not reduce performance greatly, likely because these flows were partially treated, and bypassing occurred during the highest flow rates, which were seen to have the lowest pollutant levels.

8.5 Objective #3

“Verification of the Up-Flo[®] Filter in actual full-scale operation and determine the expected treatability of the device following the different protocols and the proposed protocol framework.”

Chapter 6 of this report describes the evaluation of performance following the different protocols and the Section 6.6 shows the proposed protocol framework. This objective was also achieved in the evaluations under varying conditions and under the controlled and full-scale tests. During the controlled sediment tests of the full-sized treatment system, 90 to 100% of the particles larger than 30 μm , and from 40 to 90% of the smaller particles (0.45 to 30 μm) were captured, over the range of influent concentrations. During the tests with about 100 mg/L influent SSC, the effluent averaged about 20 mg/L, with removal rates of about 80%. During tests with 500 mg/L SSC influent, the effluent averaged about 65 mg/L, with about 85% removal rates. During these initial tests, the treatment flow rates vs. head were very repeatable, with flows being approximately 55 gal/min (6 gal/min/ft²) with 20 inches of head. During the actual storm monitoring, similar results to the controlled tests were observed. About 90% to 100% reduction of the particles larger than larger than 30 μm , and 40 to 80% of the smaller particles were captured. During the actual storm monitoring, the data indicated about 10 to 100% nutrients reduction and 30 to 98% reduction for bacteria. Most of the metals in the effluent were below the detection limits and only periodic low concentrations of metals were seen in the influent samples.

All the full-scale storm performance data were analyzed according to the existing protocols. The data from the different scales and conditions were also extremely useful in order

to develop the protocol framework as described in the Section 6.6. Each protocol applied different criteria and qualified sampling selection procedures.

CHAPTER 9

9: RECOMMENDATIONS AND FUTURE RESEARCH NEEDS

Recommendation and future research subjects of this research are presented in this chapter.

9.1 Recommendations

There are several recommendations for the evaluation framework of a stormwater control device.

1. It is recommended that site hydraulic conditions, storm characteristics, and expected pollutants concentrations for candidate monitoring locations be evaluated prior to selecting the monitoring site or the start of the evaluation process of the device. This will enable specific collection methods to be selected to reflect the local conditions, especially to develop alternative sampling programs (a major factor affecting the sampling frequency and numbers of subsamples) reflecting the range of site conditions. Historical data can be used to help determine the likely minimum rain depth, storm duration, and the minimum time between storms that must be considered when designing the monitoring program that will meet protocol objectives.
2. When selecting the monitoring site, drainage area delineations also need to be performed precisely from a detailed contour map and also to verify the determined drainage area by

visiting the site during the storm events. During past performance tests, drainage area errors have been identified part way thru the monitoring programs, resulting in actual gross under-sizing, or even over-sizing of the stormwater control device used in the performance tests.

3. It is recommended that the performance monitoring be conducted in stages, starting with pilot-scale and full-scale evaluation tests in the laboratory, followed by full-scale (or prototype pilot-scale) tests in the field with controlled and then finally under actual storm conditions for the final performance tests. If time or finances limit this full range of tests, some of the mid-level tests can be substituted (or complemented) with computer simulations using a calibrated model that contains the unit processes being evaluated. As an example, WinSLAMM (Pitt & Voorhees, 2002) contains a wide range of processes than can be used to supplement the field or laboratory tests. Computational fluid dynamic (CFD) models have also been successfully used as a supplement to actual tests, but accurate and complete CFD models are neither inexpensive nor quick.

9.2 Future Research Subjects

Future research subjects are proposed here in order to verify and improve the protocol framework.

1. Development of a more robust protocol applicable to a wide range of technologies is needed after the development of the protocol framework. In order to establish the next level of a protocol, the following are required: a) sampling data from other in-drain stormwater treatment devices (much non-proprietary device information is available from the International BMPDatabase at: <http://www.bmpdatabase.org/>), b) laboratory and field

data of the upflow filtration device from different EPA rain zones and different geological area in order to verify the protocol framework under a wide range of conditions (upcoming tests are scheduled as part of the US EPA's Kansas City combined sewer control demonstration project, and the State of Wisconsin is planning to conduct evaluation tests of the Up-Flo[®] Filter starting this summer), for example.

2. Contribution to the development of newly proposed protocols. Many new protocols are proposed and some states are aggressively modifying the existing protocols in order to adjust for local conditions. New Jersey, New York, and Georgia are actively contributing to the development of state-based protocols, along with various international agencies and engineering societies. Future research needs to include the development of broadly acceptable evaluation protocols reflecting these unique local conditions and objectives.

REFERENCES

- Andoh, R., Pitt, R., Togawa, N., & Osei, K. (2009a). Stormwater treatment using the high-rate upflow filtration system. *6th International Water Sensitive Urban Design Conference and Hydropolis*.
- Andoh, R., Pitt, R., Togawa, N., & Osei, K. (2009b). The Up-Flo[®] Filter - An Advanced Novel High-Rate Filtration System for Stormwater Treatment *Stormwater 2009*.
- Standard Methods for the Examination of Water and Wastewater, 2540 D C.F.R. (1995).
- Standard Test Methods for Determining Sediment Concentration in Water Samples, D-3977-97B C.F.R. (1997).
- Avilarangel, H. F. (2008). Scour of Captured Sediment from a Stormwater Hydrodynamic Device. *Ph.D. Dissertation*(University of Alabama at Tuscaloosa).
- BBA. (2010). British Board of Agreement.
- BMP. (2007). *International Stormwater Best Management Practices Database*. Retrieved. from.
- Burian, S. J., & Edwards, F. G. (2002). *Historical Perspectives of Urban Drainage*. Paper presented at the Global Solutions for Urban Drainage.
- Burton, A., & Pitt, R. (2001). *Stormwater Effects HandBook: A Toolbox for Watershed Managers, Scientists, and Engineers*: Lewis Publishers.
- Burton, G. A., & Pitt, R. (2001). *Stormwater Effect Handbook: A Tool Box for Watershed Managers, Scientists, and Engineers*. (CRC Press, Inc).

- Chan, L., Li, Y., & Stenstrom, M. K. (2008). Protocol evaluation of the total suspended solids and suspended sediment concentration methods: Solid recovery efficiency and application for stormwater analysis. *Water Environmental Research*, pp. 796-805.
- Clark, S. E. (2000). Urban Stormwater Filtration: Optimization of Design Parameters and a Pilot-Scale Evaluation. *Ph.D. Dissertation in Environmental Health Engineering*(Department of Civil and Environmental Engineering, University of Alabama at Birmingham), 430 pages.
- Clark, S. E., & Pitt, R. (2008). Comparison of stormwater solids analytical methods for performance evaluation of manufactured treatment devices. *Journal of Environmental Engineering*, Vol. 134, pp. 259-264.
- Clark, S. E., & Siu, C. (2008). Measuring solids concentration in stormwater runoff: Comparison of analytical methods. *Environmental Science Technology*, Vol. 42, pp. 511-516.
- Clark, S. E., Siu, C. Y. S., Pitt, R., Roenning, C. D., & Treese, D. P. (2009). Peristaltic Pump Autosamplers for Solids Measurement in Stormwater Runoff. *Water Environmental Research*, Vol. 80(Water Environment Federation).
- Cochran, W. G. (1977). *Sampling Techniques (3rd ed.)*. New York: John Wiley & Sons.
- Ecology. (2001). Stormwater Management Manual for Western Washington. (Washington State Department of Ecology).
- Efron, B., & Tibshirani, R. J. (1994). *An Introduction to the Bootstrap*: Chapman and Hall/CRC.
- Environmental Water Resources Institute, Urban Water Resources Research Council, & Gross Solids Technical Committee. (2007). *ASCE Guideline for Monitoring Stormwater Gross Pollutants*. Paper presented at the 9th Biennial Conference on Stormwater Research & Watershed Management, University of Central Florida.
- Standard Operating Procedure for the Analysis of Residue, Non-filterable (suspended solids), Water, 160.2 C.F.R. (1999).
- EPA. (2006). Wadeable Streams Assessment: A Collaborative Survey of the Nation's Streams. (Washington DC: EPA Office of Water).

- EPA. (2011). Phosphorus. from <http://water.epa.gov/type/rs/monitoring/vms56.cfm>
- ETV. (2002). ETV Verification Protocol Stormwater Source Area Treatment Technologies. *Draft 4.1*(US EPA).
- ETV Canada. (2010). Environmental Technology Verification Program in Canada.
- Gibbons, J. D. (1997). *Nonparametric Methods for Quantitative Analysis* (3rd ed.). Columbus, OH: American Sciences Press.
- Gill, S. (2004). *Evaluation of Filter Media and Upflow Columns for Removal of Metals from Stormwater Runoff: Lab-Scale Study*. The University of Alabama, Tuscaloosa.
- Glysson, G. D., & Gray, J. R. (2002). *Total Suspended Solids Data for Use In Sediment Studies*. Paper presented at the Turbidity and Other Sediment Surrogates Workshop, Reno, NV.
- Glysson, G. D., Gray, J. R., & Conge, L. M. (2000). *Adjustment of Total Suspended Solids Data for Use in Sediment Studies*. Paper presented at the ASCE's 2000 Joint Conference on Water Resources Engineering and Water Resources Planning and Management, Minneapolis, MN.
- Gray, H. F. (1940). Sewerage in Ancient and Mediaeval Times. *Sewage Works Journal*, Vol. 12, pp. 939-946.
- Gray, J. R., Glysson, G. D., Turcios, L. M., & Schwarz, G. E. (2000). Comparability of Suspended-Sediment Concentration and Total Suspended Solids Data. *U.S. Geological Survey Water Resources Investigation Report 00-4191*(U.S. Geological Survey).
- Protocol for the Verification of In-Drain Treatment Technologies, 40CFR35.6450 C.F.R. (2001).
- Khambhammetts, U. (2006). Evaluation of Upflow Filtration for the Treatment of Stormwater. *MSCE Thesis*(University of Alabama at Tuscaloosa).
- Khambhammettu, U. (2006). Evaluation of Upflow Filtration for the Treatment of Stormwater. *MSCE Thesis*(University of Alabama at Tuscaloosa).
- Lager, J. A., Smith, W. G., & Tchobanoglous, G. (1977). Catchbasin Technology Overview And Assessment. *EPA-600/2-77-051, Contract No. 68-03-0274*(USA EPA).

- Lenhart, J. H. (2007). BMP Performance Expectation Functions-A Simple Method for Evaluating Stormwater Treatment BMP Performance Data. (CONTECH Stormwater Solutions).
- Maestre, A., & Pitt, R. (2006). *Identification of Significant Factors Affecting Stormwater Quality Using the NSQD*. Paper presented at the Stormwater and Urban Water Systems Modeling, Ontario.
- Maestre, A., Pitt, R., & Williamson, D. (2004). *Nonparametric Statistical Tests Comparing First Flush and Composite Samples from the National Stormwater Quality Database*. Paper presented at the Stormwater and Urban Water Systems Modeling, Ontario.
- MDM. (2010). New York State Stormwater Management Design Manual.
- MSM. (2007). The Minnesota Stormwater Manual.
- NJCAT. (2009). *New Jersey Corporation for Advanced Technology (NJCAT)*. Retrieved. from.
- Protocol for Manufactured Filtration Devices for Total Suspended Solids Based on Laboratory Analysis, N.J.A.C. 7:8-5 C.F.R. (2009).
- Orlich, S. (2010). Kruskal-Wallis Multiple Comparisons with a MINITAB Macro. (Minitab, Inc.).
- Penn State Harrisburg. (2007). *In-Drain Treatment Device: The Hydro International Up-FlowTM Filter*. Retrieved. from.
- Pitt, R. (1979). Demonstration of Nonpoint Pollution Abatement Through Improved Street Cleaning Practices. *EPA/2-85/038, Contract No. R-805929012*(USA EPA).
- Pitt, R. (1985). Characterizing and Controlling Urban Runoff through Street and Sewerage Cleaning. *EPA/2-85/038, Contract No. R-805929012*(USA EPA).
- Pitt, R., Bannerman, R., Clark, S., & Williamson, D. (2004). Sources of Pollutants in Urban Areas (Part 1) - Older Monitoring Projects. *Effective Modeling of Urban Water Systems, Monograph 13*(CHI).

- Pitt, R., Clark, S. E., & Lake, D. (2007). Construction Site Erosion and Sediment Controls. (DEStech Publications, Inc.), pp. 299-300.
- Pitt, R., & Field, R. (1998). *An Evaluation of Storm Drainage Inlet Devices for Stormwater Quality Treatment*. Paper presented at the Water Environment Federation 71st Annual Conference & Exposition, Orlando, Florida.
- Pitt, R., & Khambhammettu, U. (2006). Field Verification Report for the Up-Flo™ Filter. Small Business Innovative Research, Phase 2 (SBIR2) Report. (US EPA).
- Pitt, R., Maestre, A., Hyche, H., & Togawa, N. (2008). The Updated Stormwater Quality Database (NSQD), Version 3. *WEFTEC 2005: Session 11 through Session 20*(Water Environment Federation), pp. 1007-1026.
- Pitt, R., Robertson, B., & Barron, P. (1999). Stormwater Treatment at Critical Areas: The Multi-Chambered Treatment Train (MCTT). *EPA/600/R-99/017, Contract No. CR-819573*(USA EPA).
- Pitt, R., & Voorhees, J. (2002). SLAMM, the Source Loading and Management Model. *Wet-Weather Flow in the Urban Watershed: Technology and Management*(CRC Press).
- Pratap, M. (2004). *Designing and Operation of Upflow Filters for the Rapid and Effective Treatment of Stormwater at Critical Source Areas*. The University of Alabama, Tuscaloosa.
- Schueler, T. (1996). Irreducible Pollutant Concentrations Discharged From Urban BMP's, *Watershed Protection Techniques. No 2, Vol 2*(Spring), page 75.
- Shaheen, D. G. (1975). Contributions of Urban Roadway Usage to Water Pollution. *600/2-75-004*(USA EPA).
- Standard Method. (2005). *Standard Methods for the Examination of Water & Wastewater* (21 ed.): American Public Association, American Water Works Association, Water Environment Federation.
- TAPE. (2002). Technology Assessment Protocol - Ecology (TAPE). (Washington State Department of Ecology Water Quality Program).

TARP. (2001). The Technology Acceptance Reciprocity Partnership (TARP).

Urbonas, B. R. (1999). Design of a Sand Filter for Stormwater Quality Enhancement. *Water Environmental Research, Vol. 71*, pp. 102-113.

US Infrastructure. (2003). UpFlow Filters for the Rapid and Effective Treatment of Stormwater at Critical Source Areas. *Small Business Innovative Research (SBIR) Phase I*(U.S. EPA).

Webster, C. (1962). The Sewers of Mohenjo-Daro. *Water Pollution Control Federation, Vol. 34*, pp. 116-123.

Method for Predicting the Efficiency of Proprietary Storm Water Sedimentation Devices, 1006 C.F.R. (2008).

APPENDICES

Appendix A.1: October 9, 2007 Rain Event and Sampling Graphs

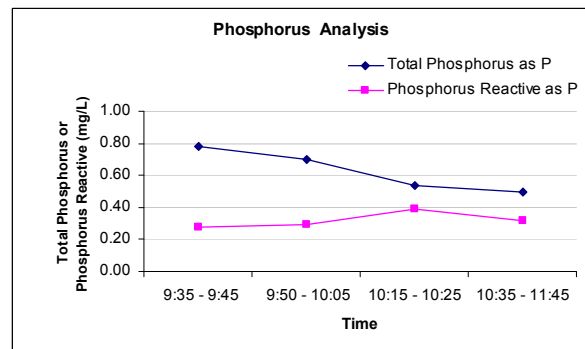
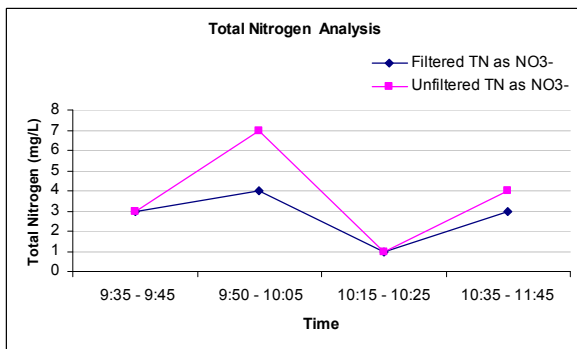
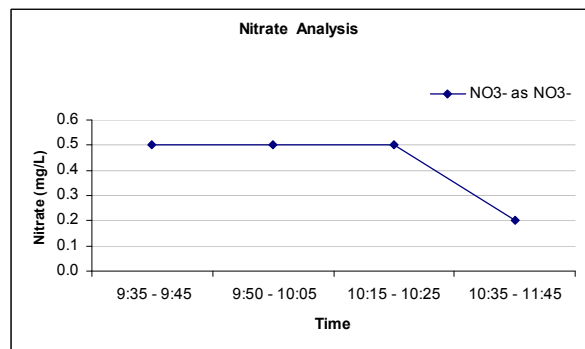
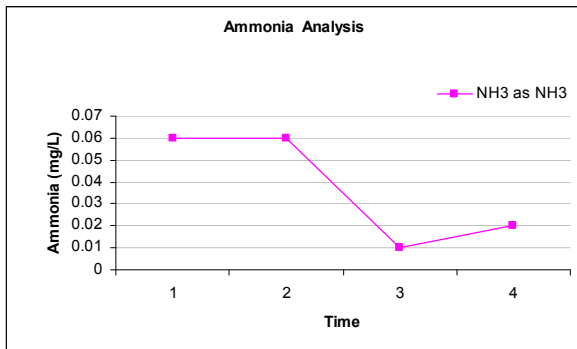
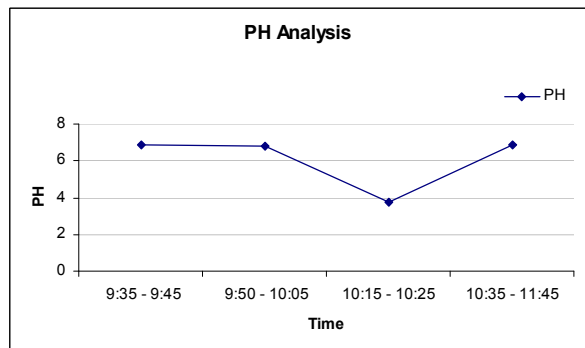
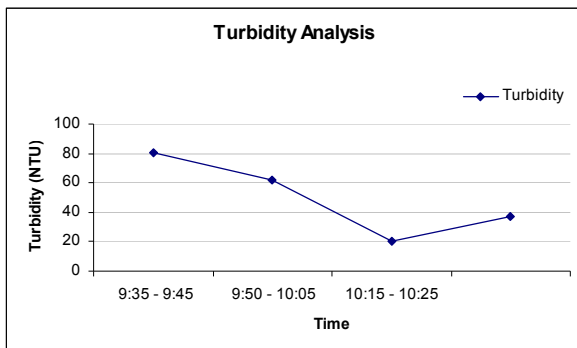
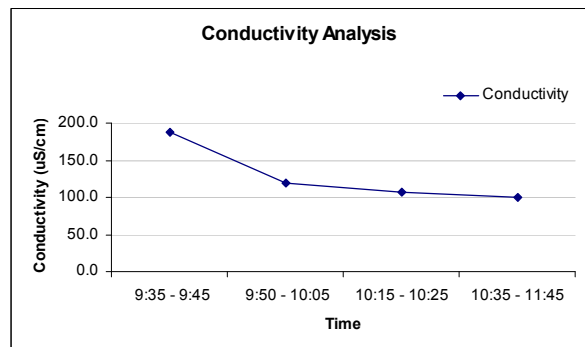
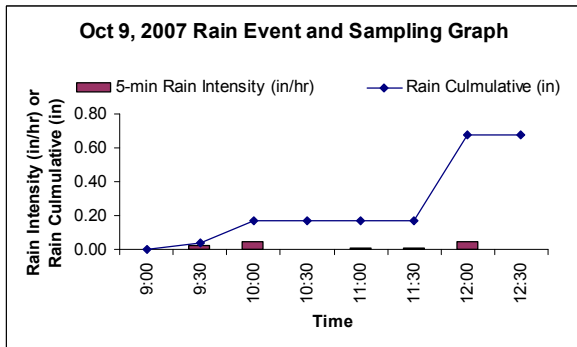

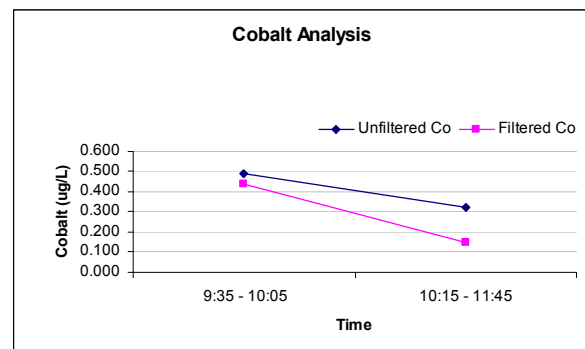
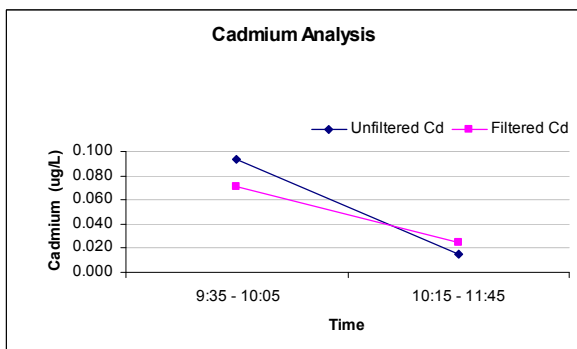
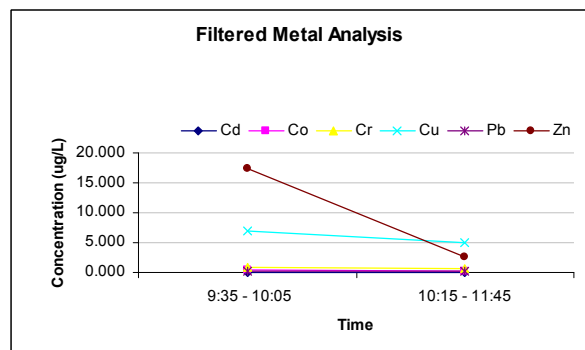
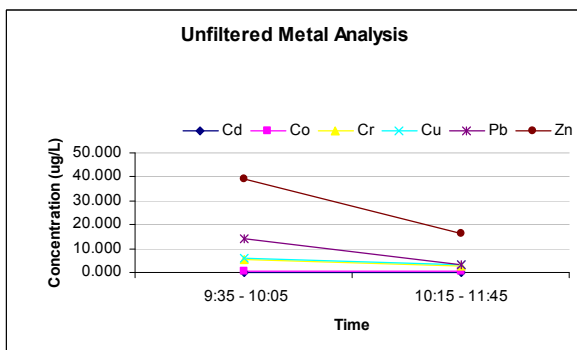
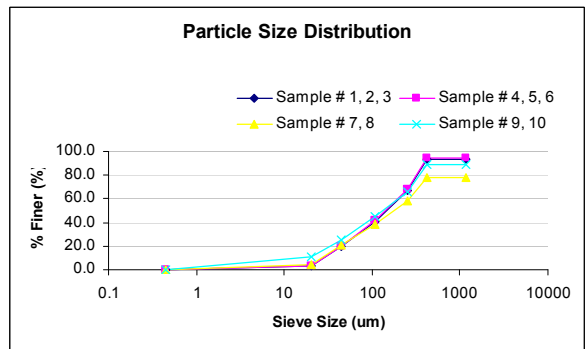
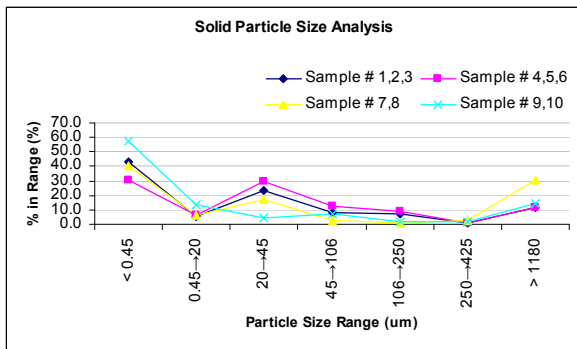
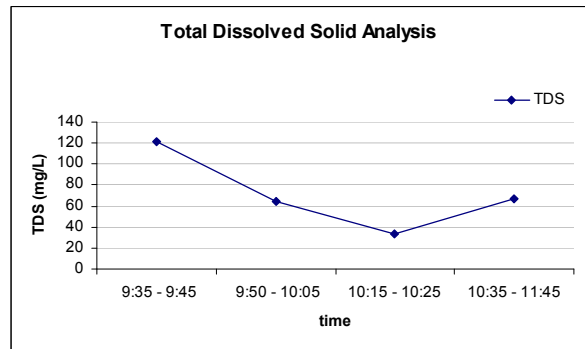
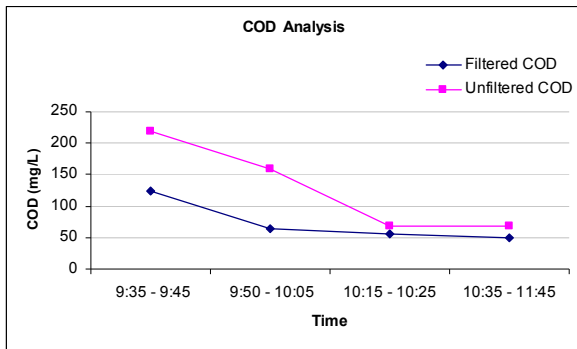

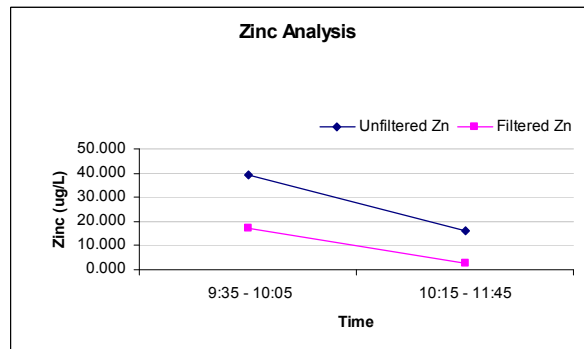
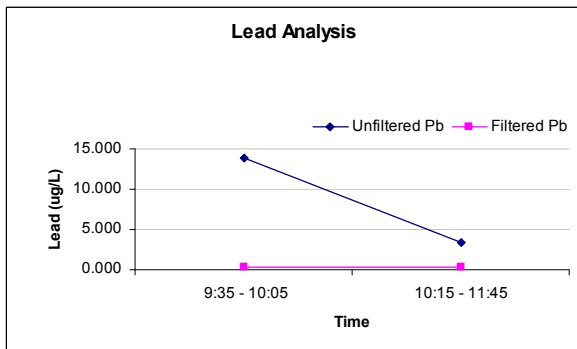
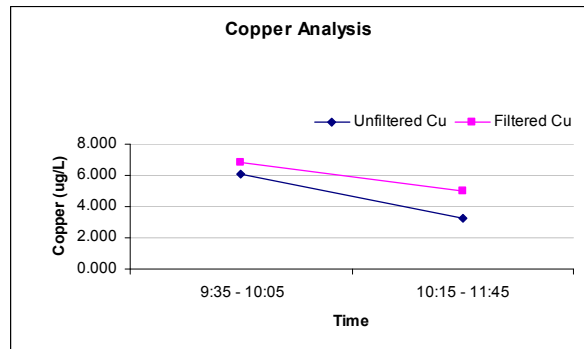
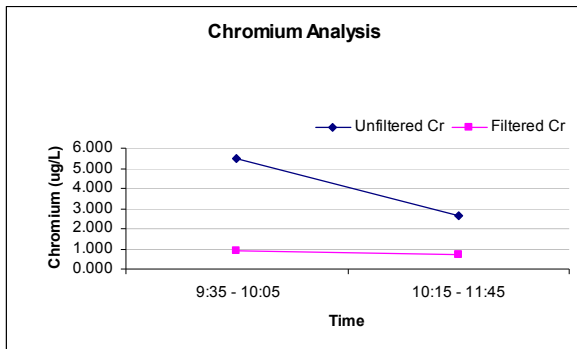

Appendix A.2: October 22, 2007 Rain Event and Sampling Graphs

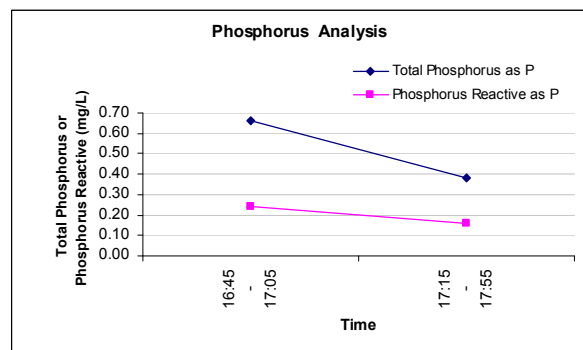
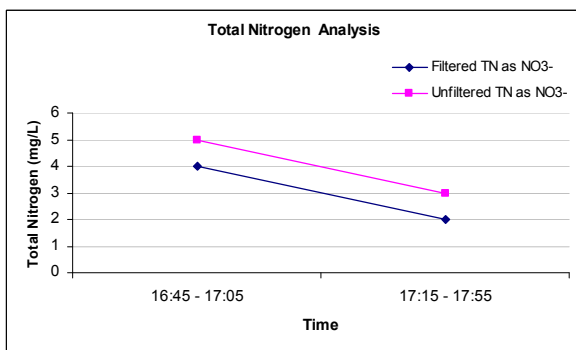
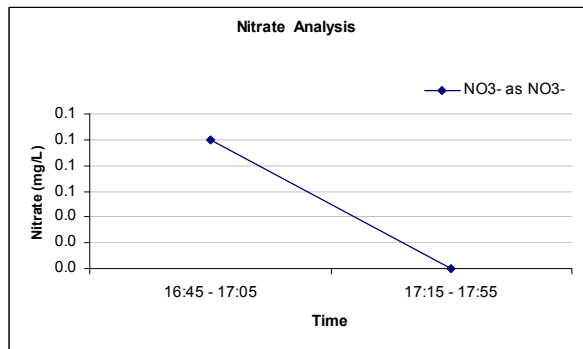
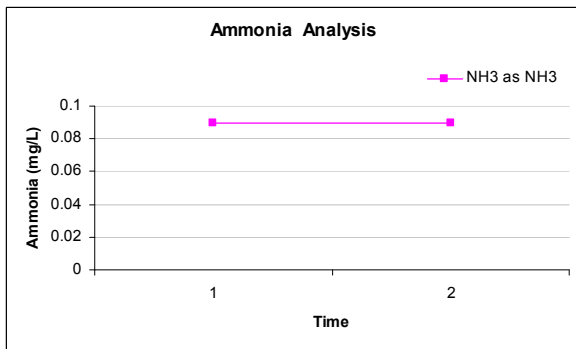
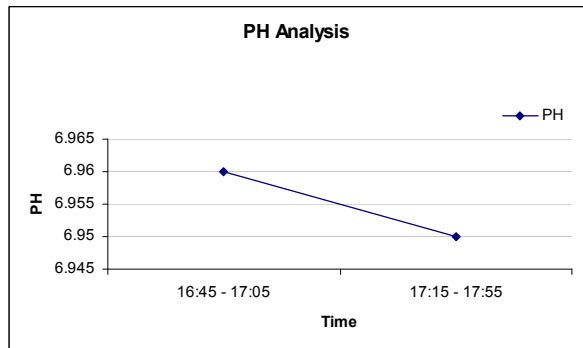
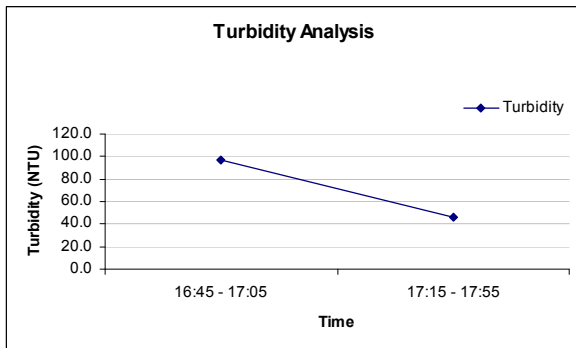
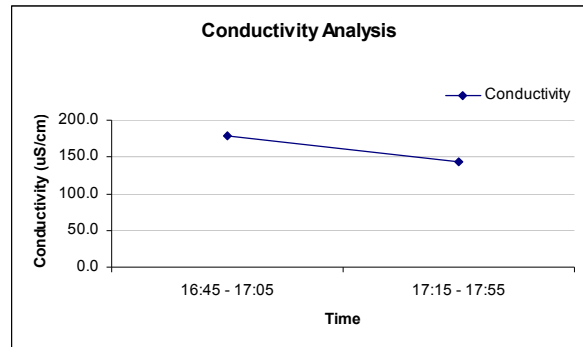
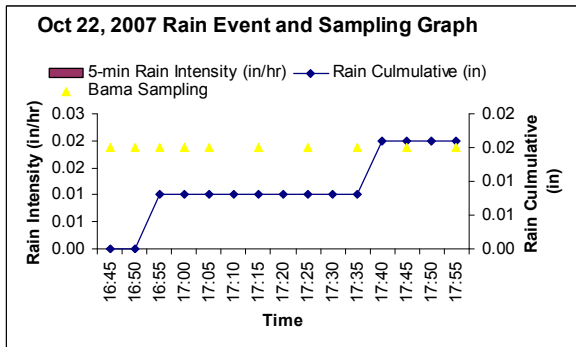

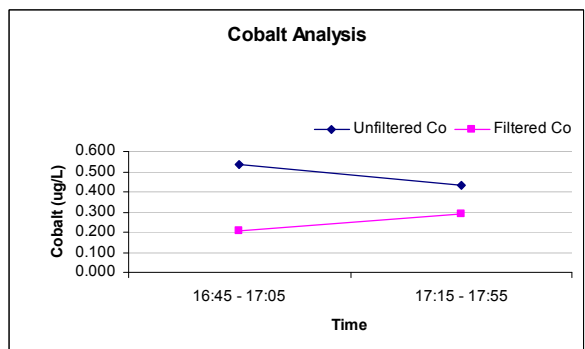
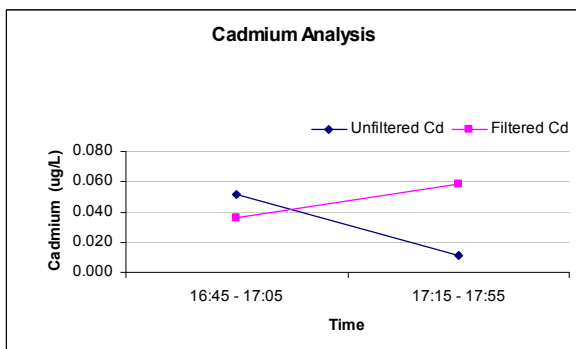
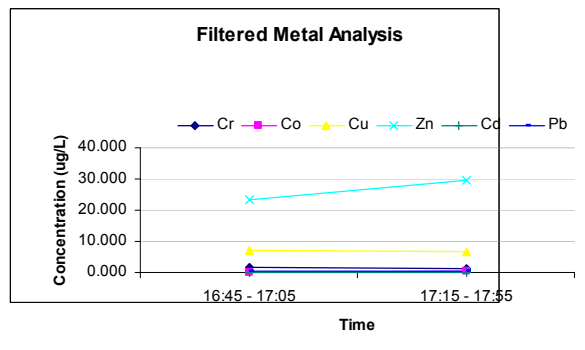
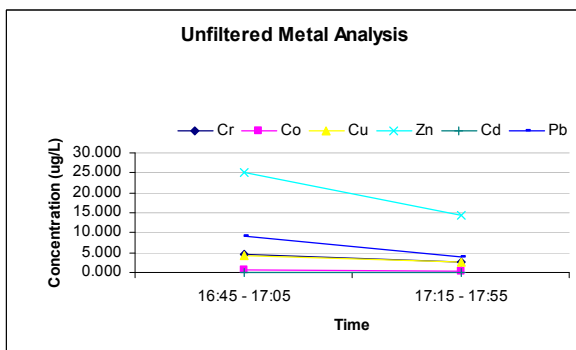
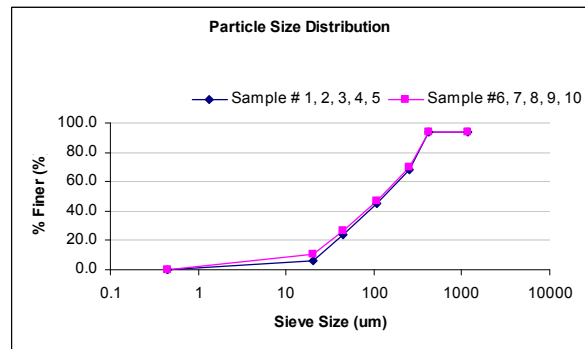
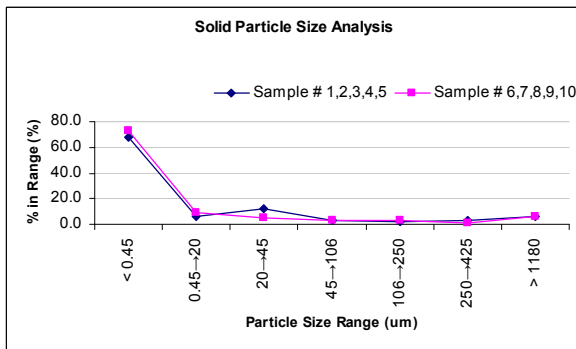
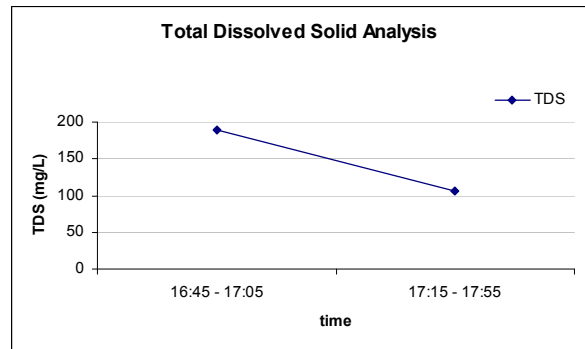
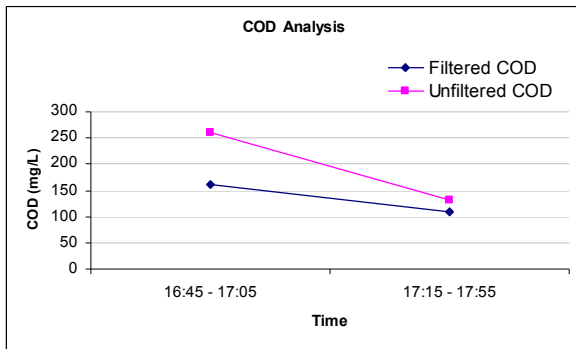

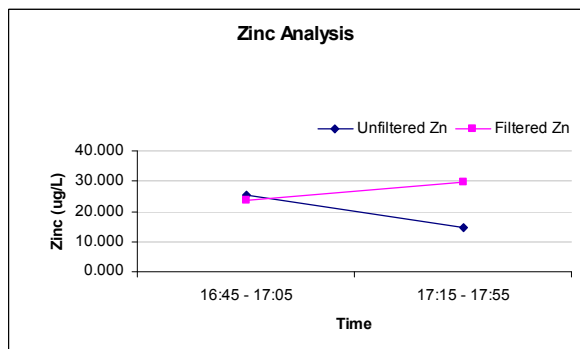
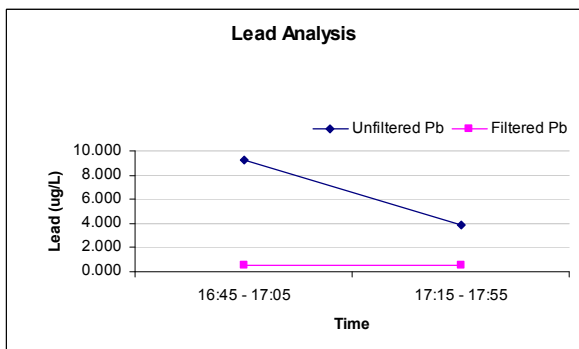
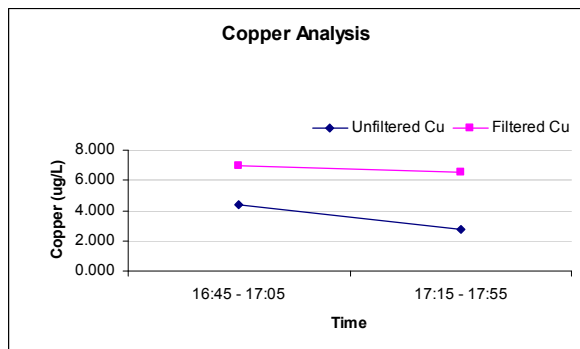
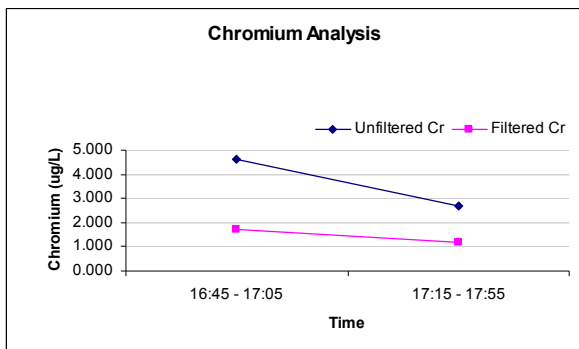

Appendix A.3: November 18, 2007 Rain Event and Sampling Graphs

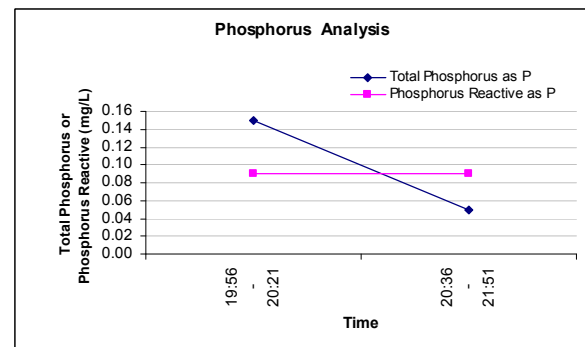
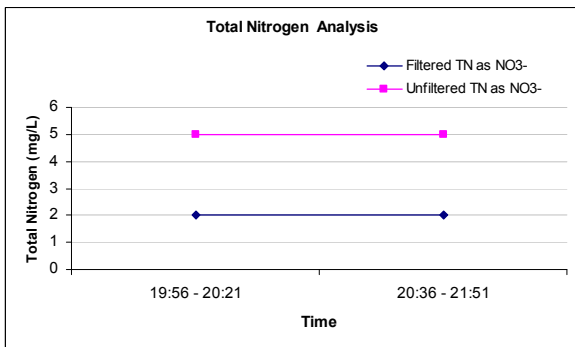
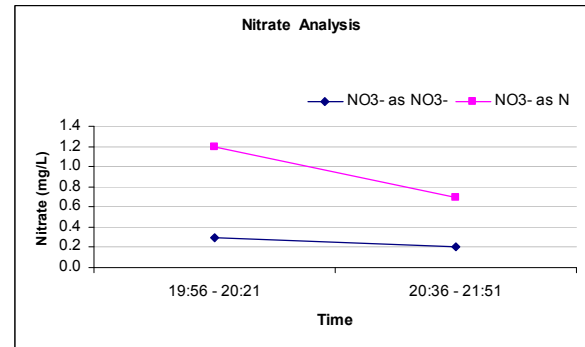
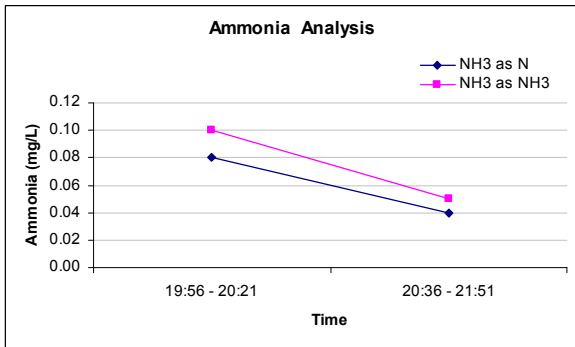
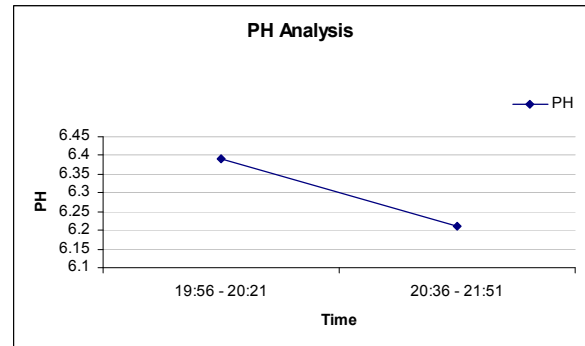
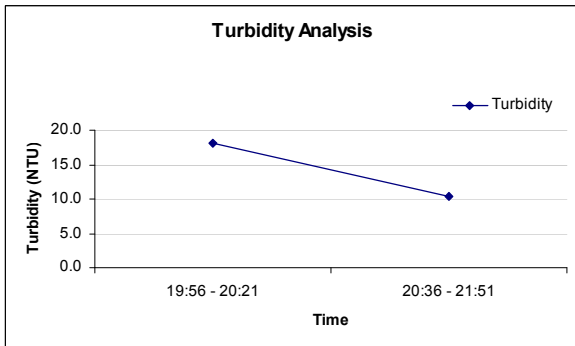
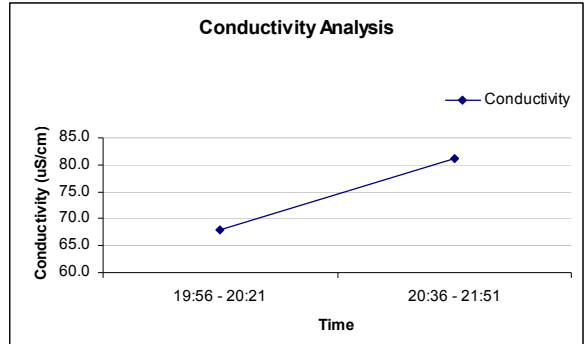
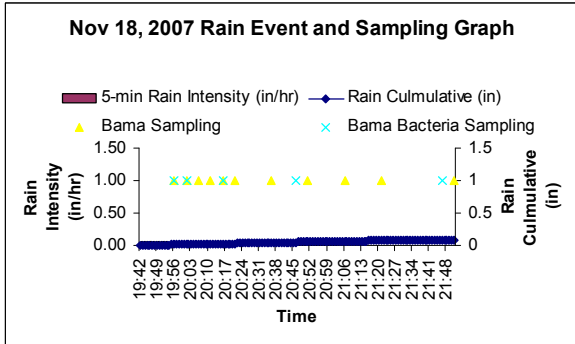

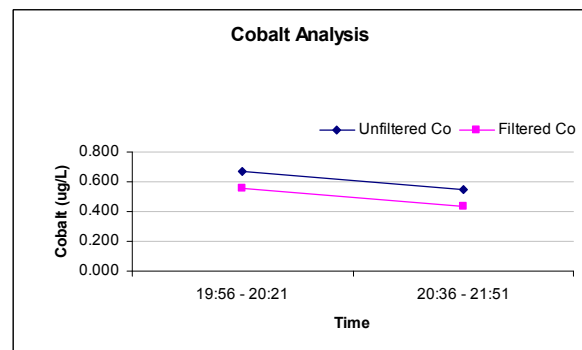
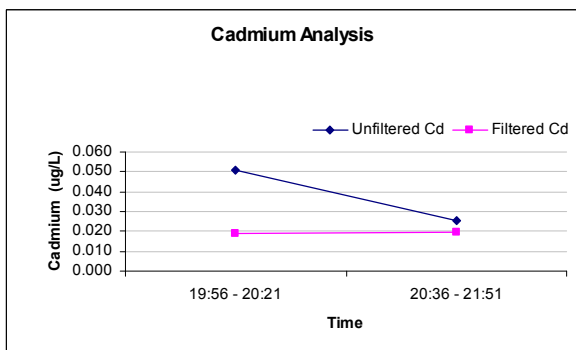
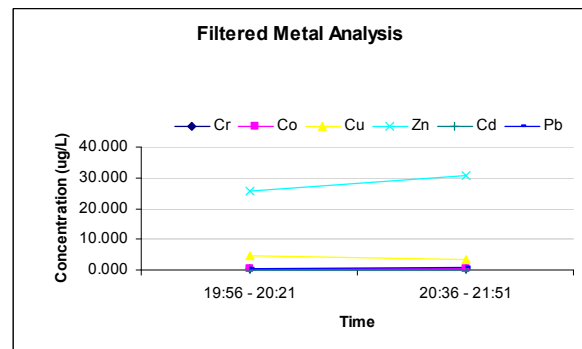
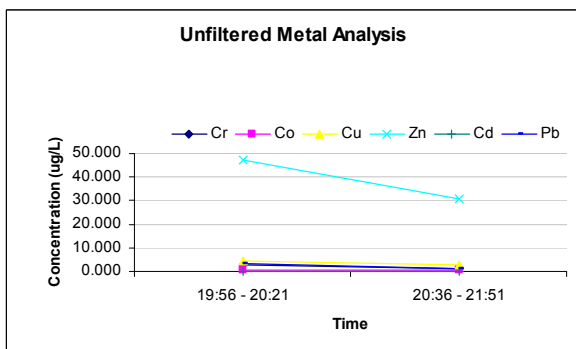
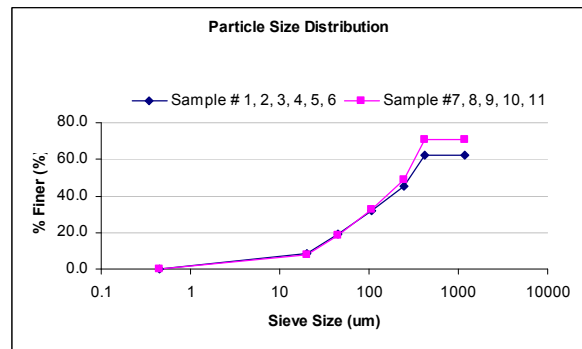
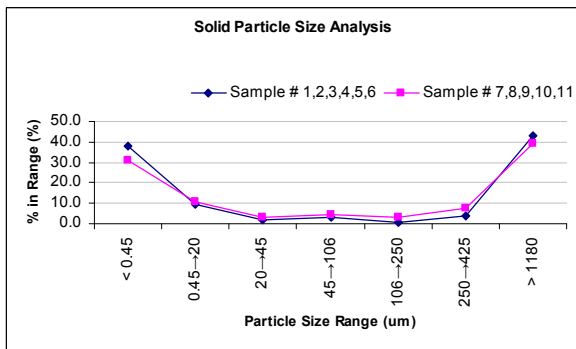
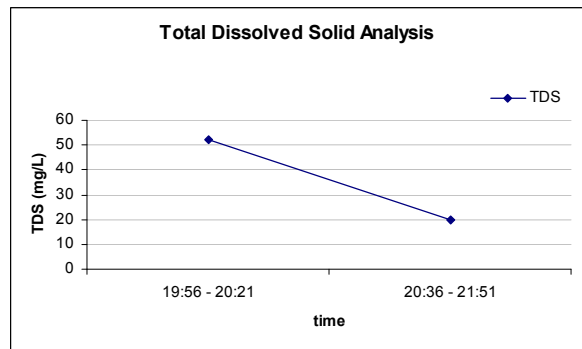
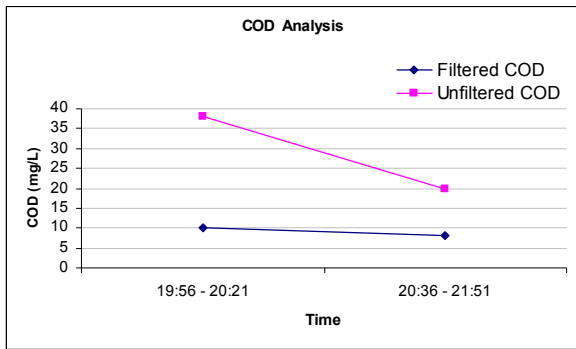

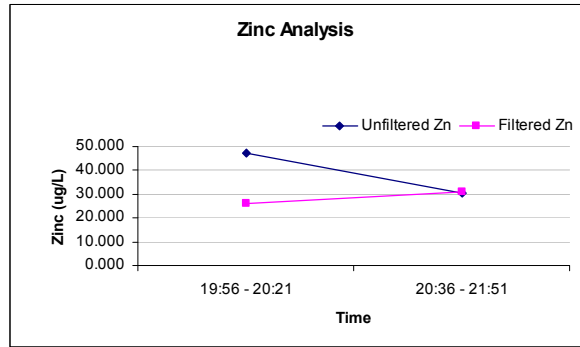
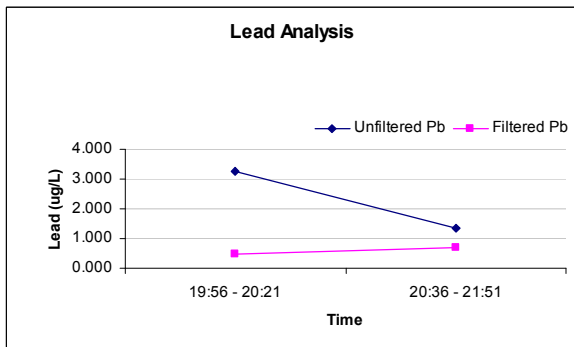
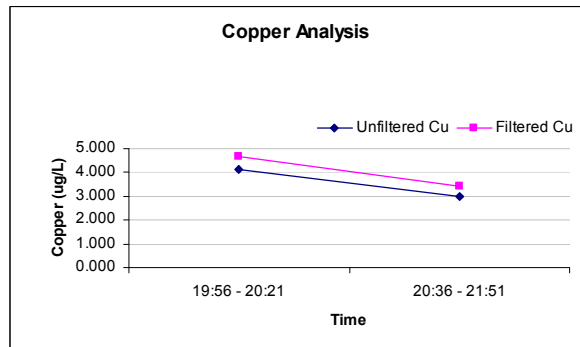
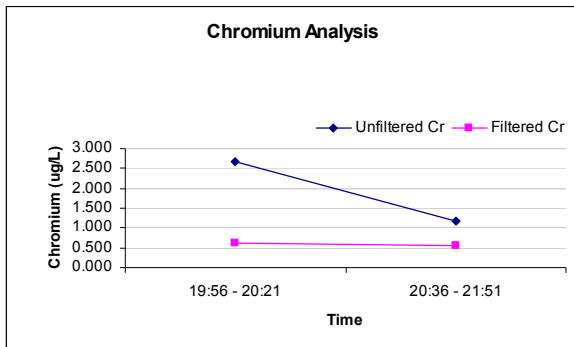

Appendix A.4: Jan 8, 2008 Rain Event and Sampling Graphs

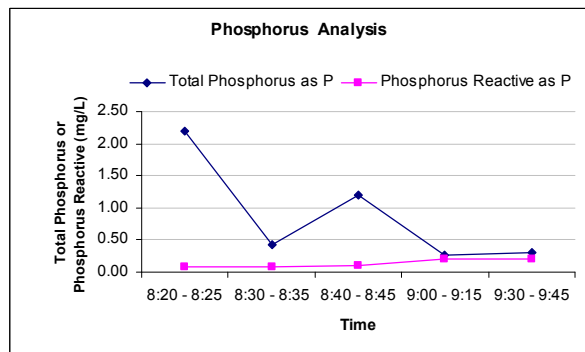
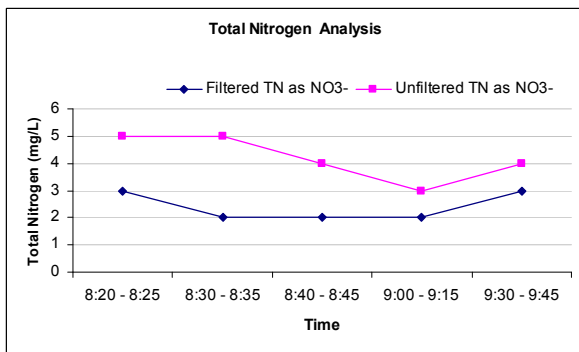
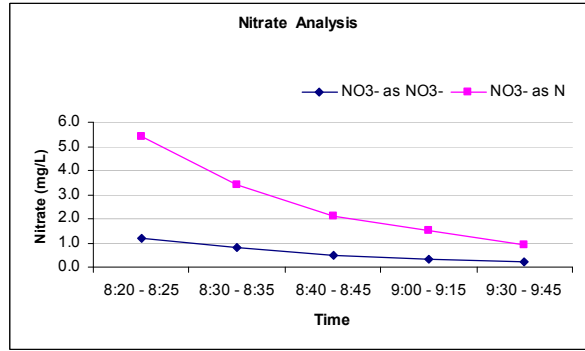
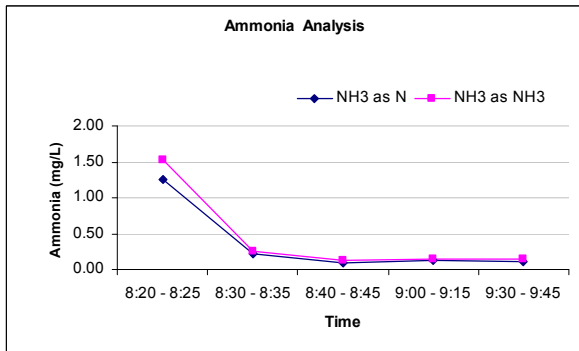
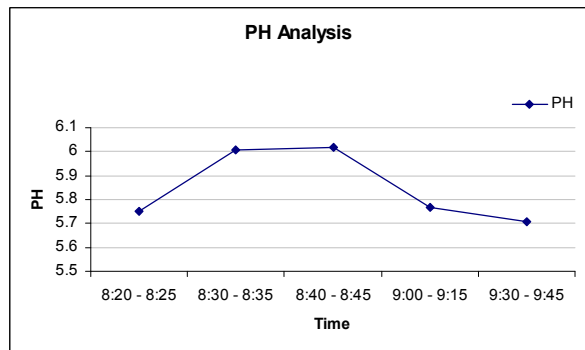
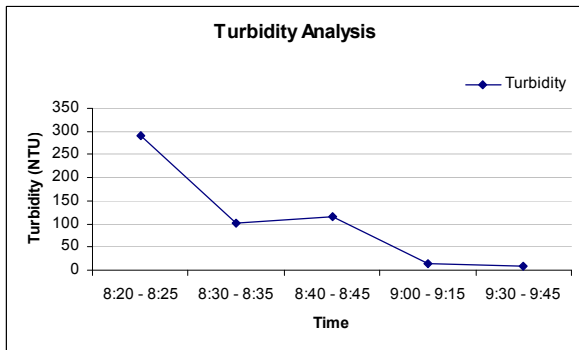
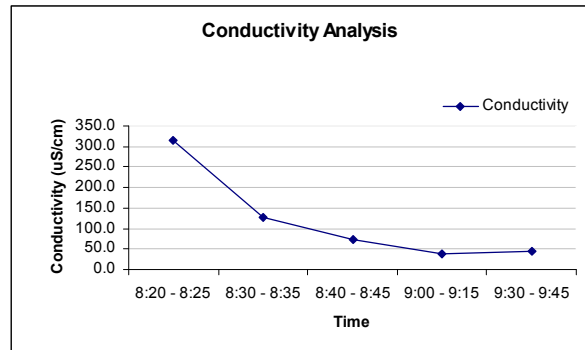
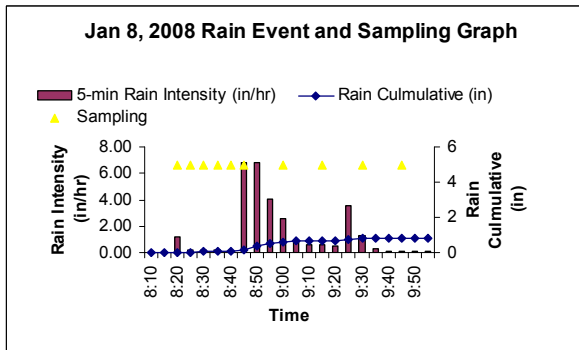

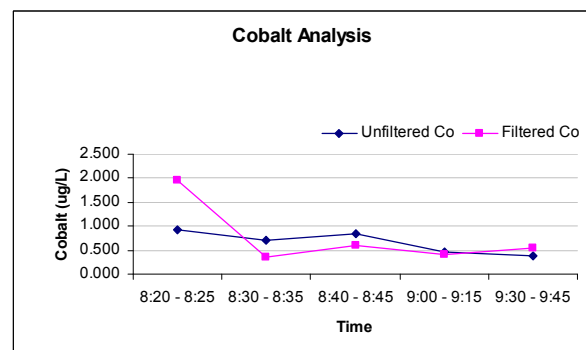
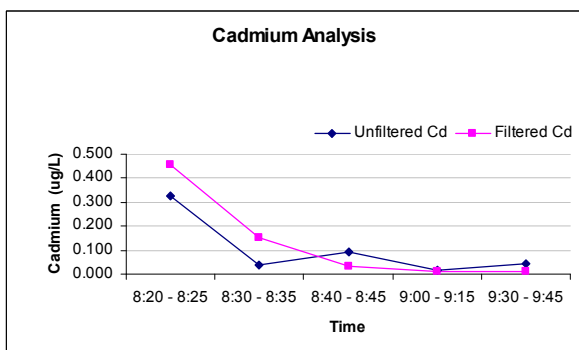
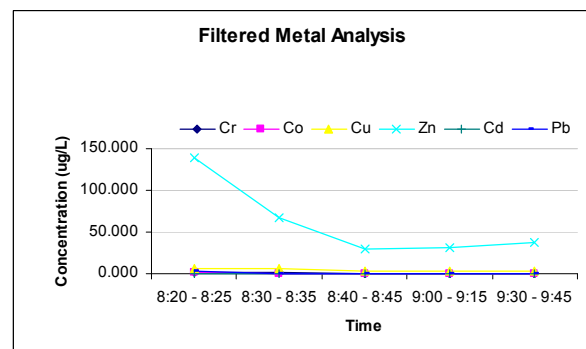
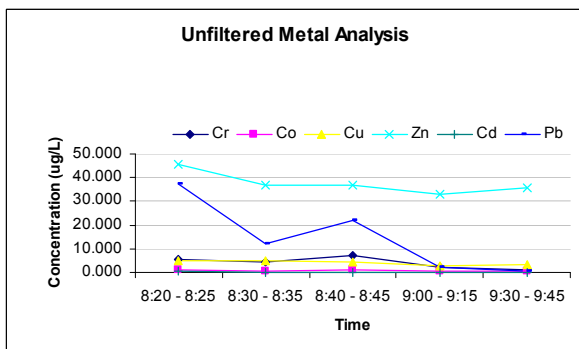
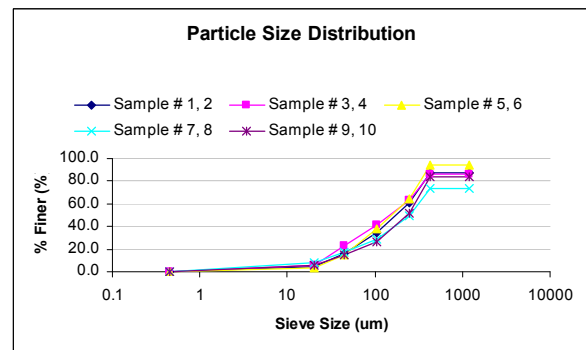
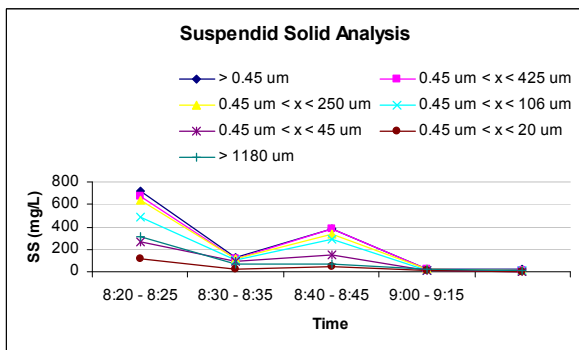
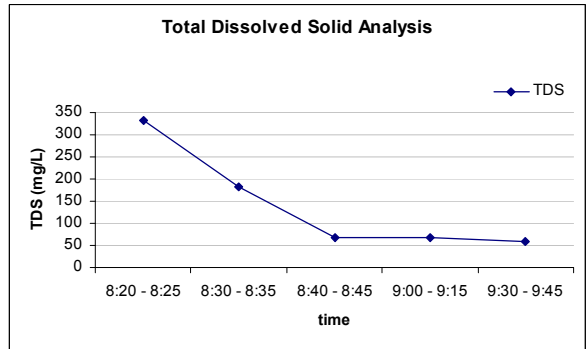
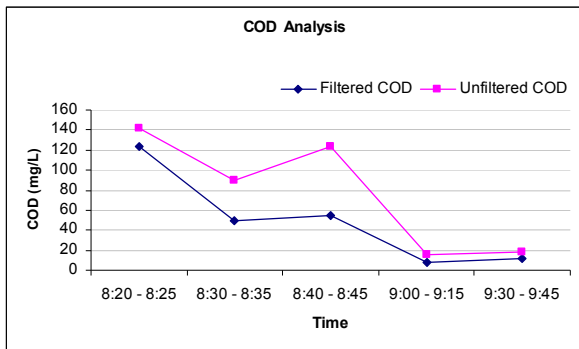

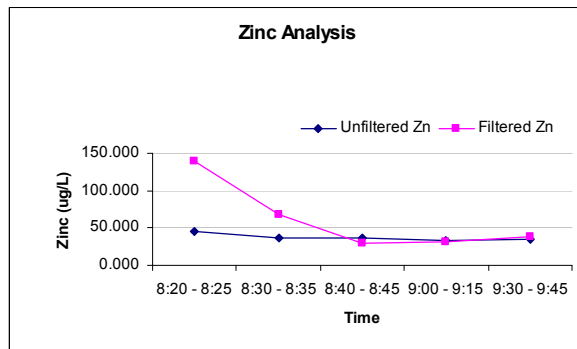
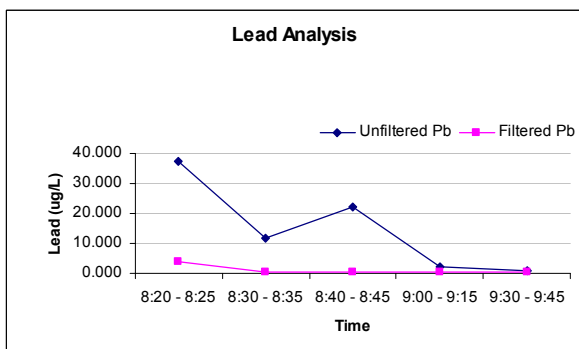
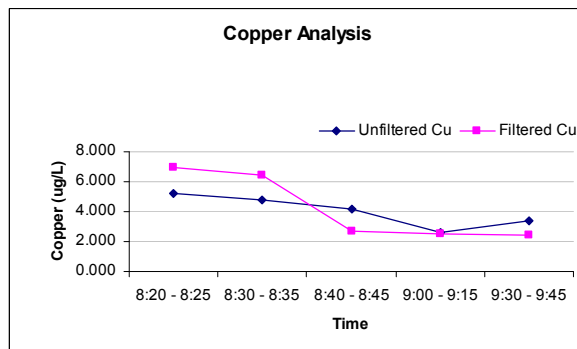
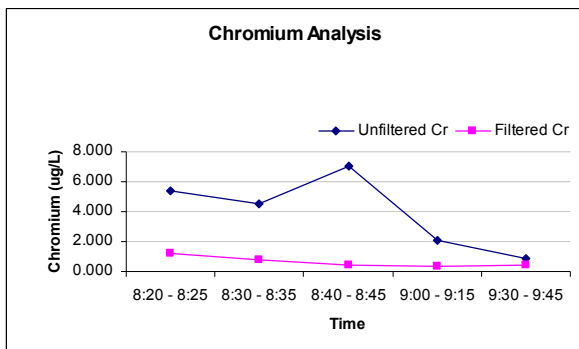

Appendix A.5: Jan 31, 2008 Rain Event and Sampling Graphs

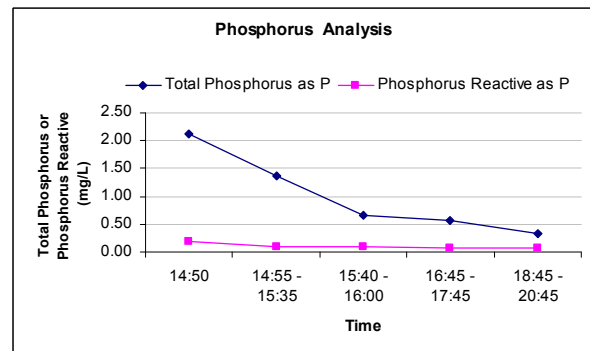
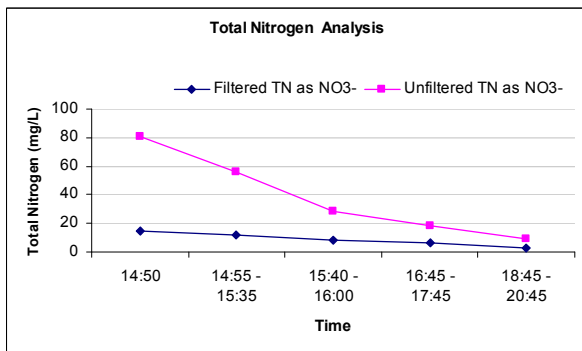
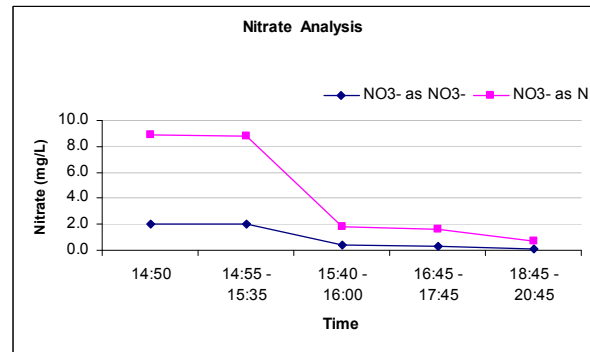
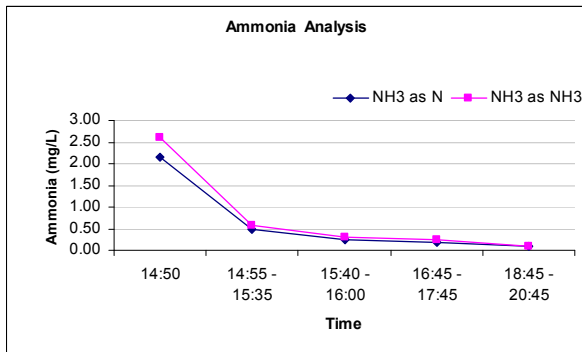
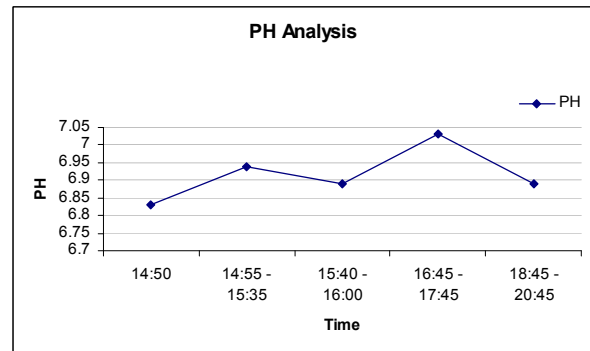
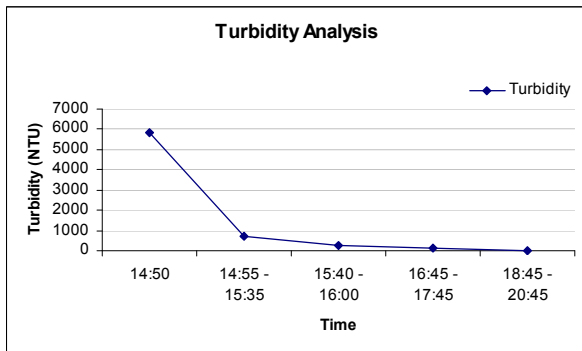
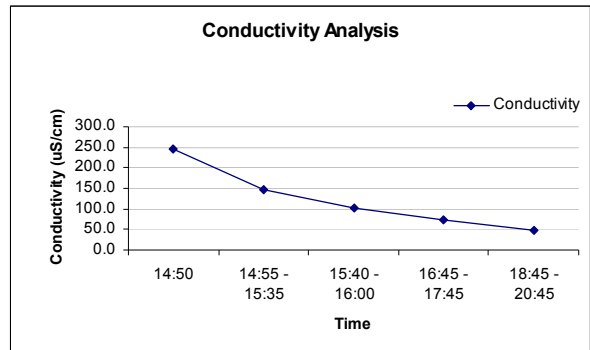
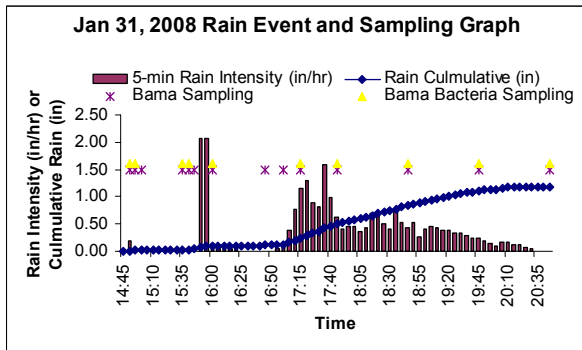

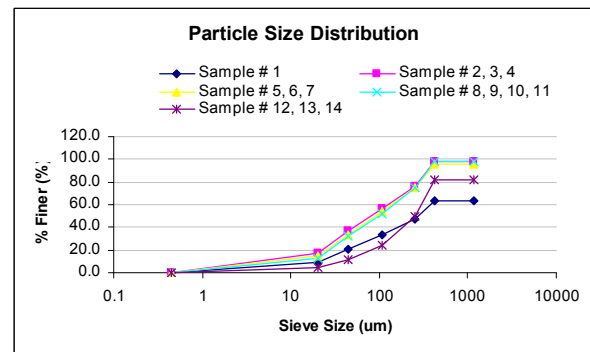
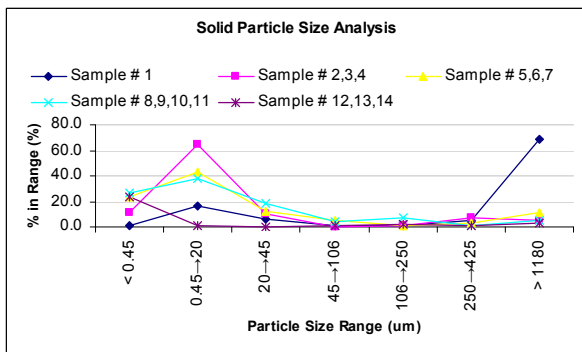
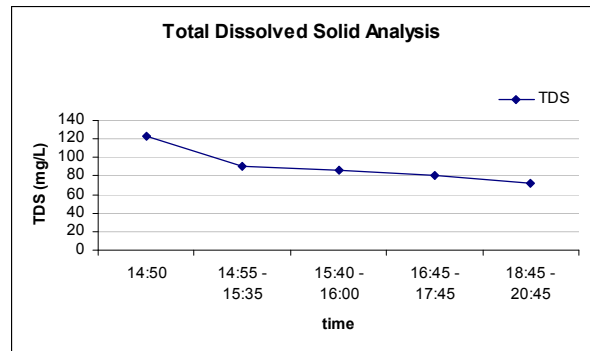
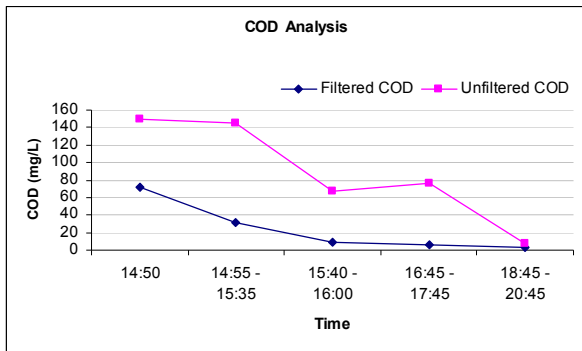

Appendix A.6: March 3-4, 2008 Rain Event and Sampling Graphs

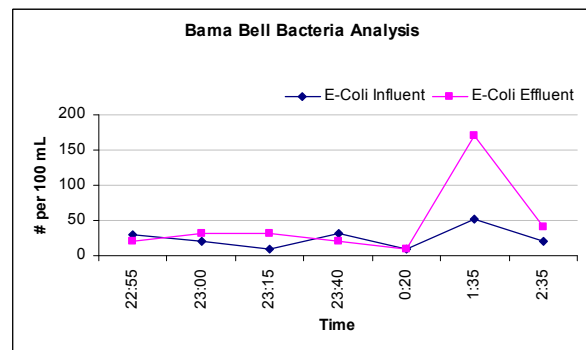
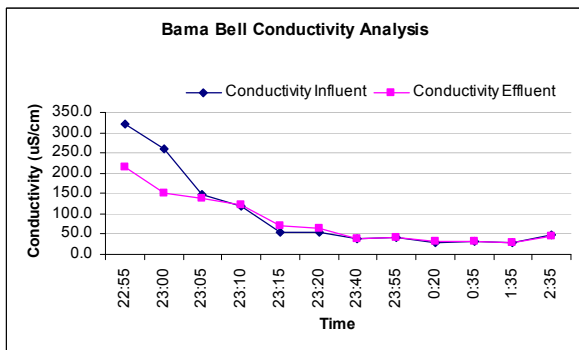
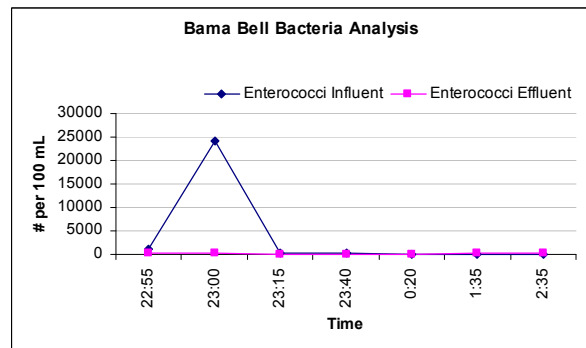
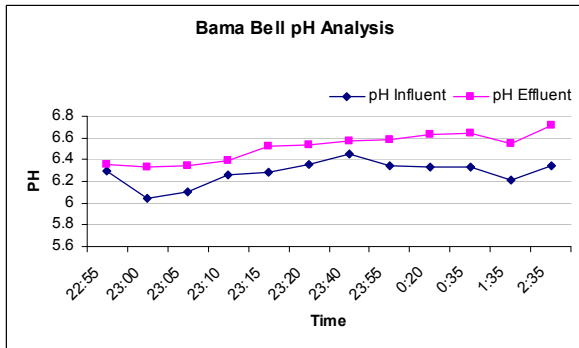
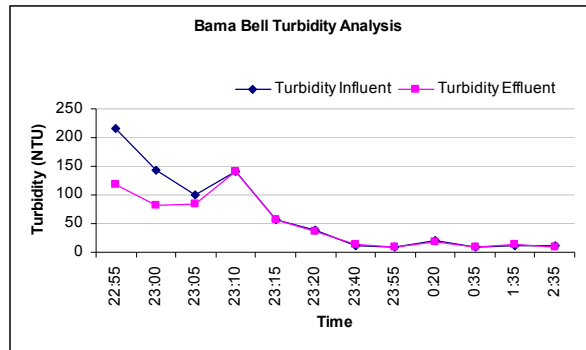
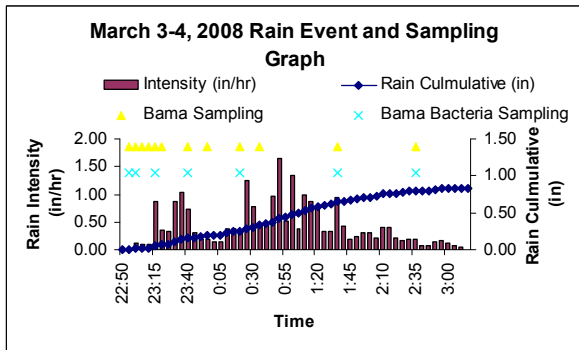

Appendix A.7: April 11, 2008 Rain Event and Sampling Graphs

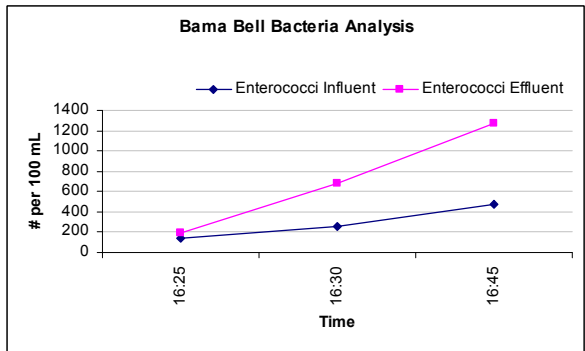
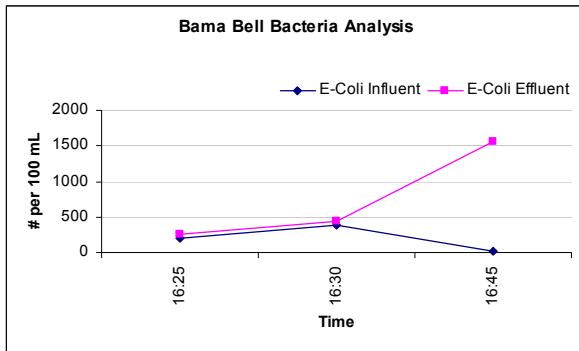
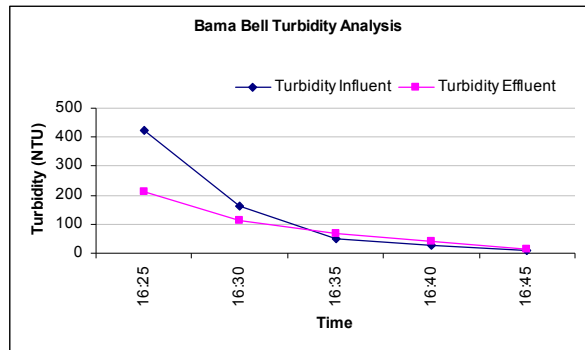
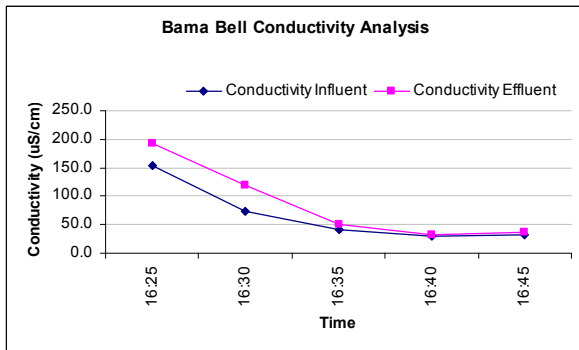
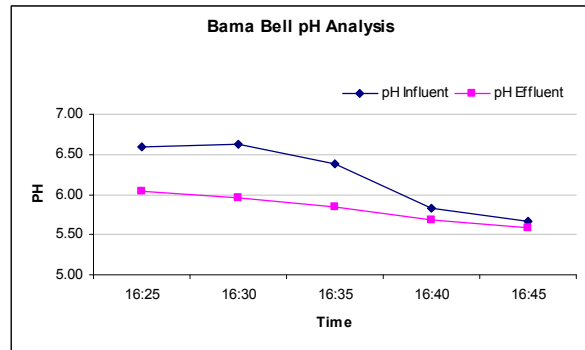
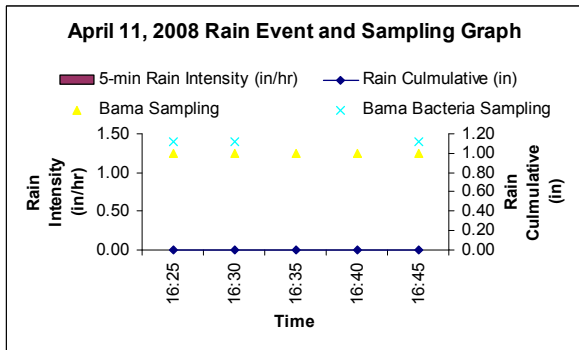

Appendix B.1: Kruskal-Wallis Multiple Comparison for the Influent SSC

Kruskal-Wallis: Multiple Comparisons

Kruskal-Wallis Test on the data

Group	N	Median	Ave Rank	Z
SBIR I	17	420.0	34.8	3.78
SBIR II	12	170.5	21.3	-0.90
Penn State	7	184.0	14.9	-1.96
Full-Scale	12	160.0	18.6	-1.68
Overall	48		24.5	

H = 15.24 DF = 3 P = 0.002
H = 15.25 DF = 3 P = 0.002 (adjusted for ties)

Kruskal-Wallis: All Pairwise Comparisons

```
-----
Comparisons:                6
Ties:                        7
Family Alpha:                0.2
Bonferroni Individual Alpha: 0.033
Bonferroni Z-value (2-sided): 2.128
-----
```

Standardized Absolute Mean Rank Differences
 $|R_{bar}(i) - R_{bar}(j)| / Stdev$

Rows: Group i = 1, ..., n
Columns: Group j = 1, ..., n

1. Table of Z-values

SBIR I	0.00000		*	*	*
SBIR II	2.55568	0.000000		*	*
Penn State	3.16434	0.961917	0.000000		*
Full-Scale	3.06877	0.473860	0.555159	0	

Adjusted for Ties in the Data

1. Table of Z-values

SBIR I	0.00000		*	*	*
SBIR II	2.55630	0.000000		*	*
Penn State	3.16511	0.962152	0.000000		*
Full-Scale	3.06951	0.473975	0.555294	0	

2. Table of P-values

SBIR I	1.00000		*	*	*
SBIR II	0.01058	1.00000		*	*
Penn State	0.00155	0.33597	1.00000		*
Full-Scale	0.00214	0.63552	0.57869	1	

Sign Confidence Intervals controlled at a family error rate of 0.2

Desired Confidence: 86.761

Sign confidence interval for median

	N	Median	Achieved Confidence	Confidence Interval		Position
				Lower	Upper	
SSC Concentration (mg/L)_SBIR I	17	420.0	0.8565	350.0	425.0	6
			0.8676	349.5	425.3	NLI
			0.9510	340.0	430.0	5
SSC Concentration (mg/L)_SBIR II	12	170.5	0.8540	92.0	252.0	4
			0.8676	91.3	262.7	NLI
			0.9614	76.0	485.0	3
			0.5469	71.0	215.0	3
SSC Concentration (m_Penn State	7	184.0	0.8676	71.0	240.5	NLI
			0.8750	71.0	242.0	2
			0.8540	83.0	310.0	4
SSC Concentration (m_Full-Scale	12	160.0	0.8676	82.0	313.7	NLI
			0.9614	61.0	390.0	3

Kruskal-Wallis: Conclusions

The following groups showed significant differences (adjusted for ties):

Groups	Z vs. Critical value	P-value
SBIR I vs. Penn State	3.16511 >= 2.128	0.0016
SBIR I vs. Full-Scale	3.06951 >= 2.128	0.0021
SBIR I vs. SBIR II	2.55630 >= 2.128	0.0106

Appendix B.2: Kruskal-Wallis Multiple Comparison for the Effluent SSC

Kruskal-Wallis: Multiple Comparisons

Kruskal-Wallis Test on the data

Group	N	Median	Ave Rank	Z
SBIR I	17	150.00	38.9	5.26
SBIR II	12	22.00	14.3	-2.93
Penn State	7	13.00	10.0	-2.96
Full-Scale	12	41.50	22.9	-0.46
Overall	48		24.5	

H = 31.97 DF = 3 P = 0.000
H = 32.01 DF = 3 P = 0.000 (adjusted for ties)

Kruskal-Wallis: All Pairwise Comparisons

```
-----
Comparisons:                6
Ties:                       12
Family Alpha:               0.2
Bonferroni Individual Alpha: 0.033
Bonferroni Z-value (2-sided): 2.128
-----
```

Standardized Absolute Mean Rank Differences
 $|Rbar(i)-Rbar(j)| / Stdev$

Rows: Group i = 1,...,n
Columns: Group j = 1,...,n

1. Table of Z-values

SBIR I	0.00000		*	*	*
SBIR II	4.66096	0.00000		*	*
Penn State	4.58913	0.63830	0.00000	*	*
Full-Scale	3.02698	1.50906	1.93367	0	

Adjusted for Ties in the Data

1. Table of Z-values

SBIR I	0.00000		*	*	*
SBIR II	4.66362	0.00000		*	*
Penn State	4.59174	0.63866	0.00000	*	*
Full-Scale	3.02870	1.50992	1.93477	0	

2. Table of P-values

SBIR I	1.00000		*	*	*
SBIR II	0.00000	1.00000		*	*
Penn State	0.00000	0.52304	1.00000	*	*
Full-Scale	0.00246	0.13106	0.05302	1	

Sign Confidence Intervals controlled at a family error rate of 0.2

Desired Confidence: 86.761

Sign confidence interval for median

	N	Median	Achieved Confidence	Confidence Interval		Position
				Lower	Upper	
SSC Concentration (mg/L)_SBIR I	17	150.0	0.8565	120.0	150.0	6
			0.8676	120.0	150.5	NLI
			0.9510	120.0	160.0	5
SSC Concentration (mg/L)_SBIR II	12	22.00	0.8540	11.00	37.00	4
			0.8676	11.00	37.42	NLI
			0.9614	11.00	46.00	3
			0.5469	8.30	20.00	3
SSC Concentration (m_Penn State	7	13.00	0.8676	7.17	31.35	NLI
			0.8750	7.10	32.00	2
			0.8540	25.0	63.0	4
SSC Concentration (m_Full-Scale	12	41.5	0.8676	25.0	64.7	NLI
			0.9614	24.0	100.0	3

Kruskal-Wallis: Conclusions

The following groups showed significant differences (adjusted for ties):

Groups	Z vs. Critical value	P-value
SBIR I vs. SBIR II	4.66362 >= 2.128	0.0000
SBIR I vs. Penn State	4.59174 >= 2.128	0.0000
SBIR I vs. Full-Scale	3.02870 >= 2.128	0.0025

Appendix B.3: Kruskal-Wallis Multiple Comparison for the Full-Scale vs. SBIR II

Kruskal-Wallis: Multiple Comparisons

Kruskal-Wallis Test on the data

Group	N	Median	Ave Rank	Z
Full Inflow	96	18.835	244.7	5.32
SBIR II Inflow	96	16.475	233.7	4.20
Full Effluent	96	3.600	157.8	-3.54
SBIR II Effluent	96	1.870	133.8	-5.99
Overall	384		192.5	

H = 70.77 DF = 3 P = 0.000
H = 70.83 DF = 3 P = 0.000 (adjusted for ties)

Kruskal-Wallis: All Pairwise Comparisons

Comparisons: 6
Ties: 131
Family Alpha: 0.2
Bonferroni Individual Alpha: 0.033
Bonferroni Z-value (2-sided): 2.128

Standardized Absolute Mean Rank Differences
 $|R_{bar}(i) - R_{bar}(j)| / Stdev$

Rows: Group i = 1, ..., n
Columns: Group j = 1, ..., n

1. Table of Z-values

Full Inflow	0.00000		*	*	*
SBIR II Inflow	0.68856	0.00000		*	*
Full Effluent	5.42718	4.73863	0.00000	*	
SBIR II Effluent	6.92718	6.23863	1.50000	0	

Adjusted for Ties in the Data

1. Table of Z-values

Full Inflow	0.00000		*	*	*
SBIR II Inflow	0.68885	0.00000		*	*
Full Effluent	5.42948	4.74063	0.00000	*	
SBIR II Effluent	6.93012	6.24127	1.50064	0	

2. Table of P-values

Full Inflow	1.00000		*	*	*
SBIR II Inflow	0.49092	1.00000		*	*
Full Effluent	0.00000	0.00000	1.00000	*	
SBIR II Effluent	0.00000	0.00000	0.13345	1	

Sign Confidence Intervals controlled at a family error rate of 0.2

Desired Confidence: 86.761

Sign confidence interval for median

	N	Median	Achieved Confidence	Confidence Interval		Position
				Lower	Upper	
Full Inflow	96	18.84	0.8154	14.00	27.00	42
			0.8676	13.49	27.85	NLI
			0.8742	13.40	28.00	41
SBIR II Inflow	96	16.48	0.8154	10.57	22.20	42
			0.8676	10.57	22.20	NLI
			0.8742	10.57	22.20	41
Full Effluent	96	3.600	0.8154	2.530	5.000	42
			0.8676	2.419	5.608	NLI
			0.8742	2.400	5.711	41
SBIR II Effluent	96	1.870	0.8154	1.333	3.526	42
			0.8676	1.238	3.679	NLI
			0.8742	1.222	3.704	41

Kruskal-Wallis: Conclusions

The following groups showed significant differences (adjusted for ties):

Groups	Z vs. Critical value	P-value
Full Inflow vs. SBIR II Effluent	6.93012 >= 2.128	0
SBIR II Inflow vs. SBIR II Effluent	6.24127 >= 2.128	0
Full Inflow vs. Full Effluent	5.42948 >= 2.128	0
SBIR II Inflow vs. Full Effluent	4.74063 >= 2.128	0

Appendix B.4.a: Kruskal-Wallis Multiple Comparison for the <0.45 µm Solids Concentration

Kruskal-Wallis: Multiple Comparisons

Kruskal-Wallis Test on the data

Group	N	Median	Ave Rank	Z
Full Inflow	12	131.55	42.5	5.14
SBIR II Inflow	12	80.50	12.6	-3.39
Full Effluent	12	102.00	27.5	0.86
SBIR II Effluent	12	80.50	15.4	-2.61
Overall	48		24.5	

H = 34.12 DF = 3 P = 0.000
H = 34.19 DF = 3 P = 0.000 (adjusted for ties)

Kruskal-Wallis: All Pairwise Comparisons

Comparisons: 6
Ties: 15
Family Alpha: 0.2
Bonferroni Individual Alpha: 0.033
Bonferroni Z-value (2-sided): 2.128

Standardized Absolute Mean Rank Differences
 $|Rbar(i)-Rbar(j)| / Stdev$

Rows: Group i = 1,...,n
Columns: Group j = 1,...,n

1. Table of Z-values

Full Inflow	0.00000		*	*	*
SBIR II Inflow	5.22704	0.00000		*	*
Full Effluent	2.62445	2.60258	0.00000		*
SBIR II Effluent	4.74589	0.48115	2.12143	0	

Adjusted for Ties in the Data

1. Table of Z-values

Full Inflow	0.00000		*	*	*
SBIR II Inflow	5.23172	0.00000		*	*
Full Effluent	2.62681	2.60492	0.00000		*
SBIR II Effluent	4.75014	0.48158	2.12334	0	

2. Table of P-values

Full Inflow	1.00000		*	*	*
SBIR II Inflow	0.00000	1.00000		*	*
Full Effluent	0.00862	0.00919	1.00000		*
SBIR II Effluent	0.00000	0.63010	0.03373	1	

Sign Confidence Intervals controlled at a family error rate of 0.2

Desired Confidence: 86.761

Sign confidence interval for median

	N	Median	Achieved Confidence	Confidence Interval		Position
				Lower	Upper	
Full Inflow	12	131.6	0.8540	130.0	140.0	4
			0.8676	130.0	140.5	NLI
			0.9614	130.0	150.0	3
SBIR II Inflow	12	80.50	0.8540	70.00	89.00	4
			0.8676	69.82	89.00	NLI
			0.9614	66.00	89.00	3
Full Effluent	12	102.0	0.8540	100.0	109.2	4
			0.8676	99.9	109.3	NLI
			0.9614	97.0	110.0	3
SBIR II Effluent	12	80.50	0.8540	79.00	88.00	4
			0.8676	78.95	88.28	NLI
			0.9614	78.00	94.00	3

Kruskal-Wallis: Conclusions

The following groups showed significant differences (adjusted for ties):

Groups	Z vs. Critical value	P-value
Full Inflow vs. SBIR II Inflow	5.23172 >= 2.128	0.0000
Full Inflow vs. SBIR II Effluent	4.75014 >= 2.128	0.0000
Full Inflow vs. Full Effluent	2.62681 >= 2.128	0.0086
SBIR II Inflow vs. Full Effluent	2.60492 >= 2.128	0.0092

Appendix B.4.b: Kruskal-Wallis Multiple Comparison for the 0.45~3 μm Solids Concentration

Kruskal-Wallis: Multiple Comparisons

Kruskal-Wallis Test on the data

Group	N	Median	Ave Rank	Z
Full Inflow	12	11.361	33.3	2.50
SBIR II Inflow	12	7.280	25.8	0.36
Full Effluent	12	4.050	19.1	-1.55
SBIR II Effluent	12	4.533	19.9	-1.31
Overall	48		24.5	

H = 7.87 DF = 3 P = 0.049
H = 7.87 DF = 3 P = 0.049 (adjusted for ties)

Kruskal-Wallis: All Pairwise Comparisons

Comparisons: 6
Ties: 9
Family Alpha: 0.2
Bonferroni Individual Alpha: 0.033
Bonferroni Z-value (2-sided): 2.128

Standardized Absolute Mean Rank Differences
 $|\bar{R}(i) - \bar{R}(j)| / \text{Stdev}$

Rows: Group i = 1, ..., n
Columns: Group j = 1, ..., n

1. Table of Z-values

Full Inflow	0.00000		*	*	*
SBIR II Inflow	1.31223	0.00000		*	*
Full Effluent	2.47865	1.16642	0.000000		*
SBIR II Effluent	2.33285	1.02062	0.145803	0	

Adjusted for Ties in the Data

1. Table of Z-values

Full Inflow	0.00000		*	*	*
SBIR II Inflow	1.31283	0.00000		*	*
Full Effluent	2.47979	1.16696	0.000000		*
SBIR II Effluent	2.33392	1.02109	0.145870	0	

2. Table of P-values

Full Inflow	1.00000		*	*	*
SBIR II Inflow	0.18924	1.00000		*	*
Full Effluent	0.01315	0.24323	1.00000		*
SBIR II Effluent	0.01960	0.30721	0.88402	1	

Sign Confidence Intervals controlled at a family error rate of 0.2

Desired Confidence: 86.761

Sign confidence interval for median

	N	Median	Achieved Confidence	Confidence Interval		Position
				Lower	Upper	
Full Inflow	12	11.36	0.8540	5.80	21.46	4
			0.8676	5.74	21.71	NLI
			0.9614	4.58	27.00	3
SBIR II Inflow	12	7.28	0.8540	4.16	10.40	4
			0.8676	4.06	10.88	NLI
			0.9614	2.08	20.80	3
Full Effluent	12	4.050	0.8540	2.700	6.770	4
			0.8676	2.692	6.771	NLI
			0.9614	2.530	6.808	3
SBIR II Effluent	12	4.533	0.8540	3.475	6.044	4
			0.8676	3.420	6.118	NLI
			0.9614	2.273	7.646	3

Kruskal-Wallis: Conclusions

The following groups showed significant differences (adjusted for ties):

Groups	Z vs. Critical value	P-value
Full Inflow vs. Full Effluent	2.47979 >= 2.128	0.0131
Full Inflow vs. SBIR II Effluent	2.33392 >= 2.128	0.0196

Appendix B.4.c: Kruskal-Wallis Multiple Comparison for the 3~12 µm Solids Concentration

Kruskal-Wallis: Multiple Comparisons

Kruskal-Wallis Test on the data

Group	N	Median	Ave Rank	Z
Full Inflow	12	42.79	34.3	2.79
SBIR II Inflow	12	19.97	22.8	-0.50
Full Effluent	12	16.50	22.3	-0.62
SBIR II Effluent	12	12.20	18.7	-1.67
Overall	48		24.5	

H = 8.38 DF = 3 P = 0.039
H = 8.39 DF = 3 P = 0.039 (adjusted for ties)

Kruskal-Wallis: All Pairwise Comparisons

Comparisons: 6
Ties: 9
Family Alpha: 0.2
Bonferroni Individual Alpha: 0.033
Bonferroni Z-value (2-sided): 2.128

Standardized Absolute Mean Rank Differences
 $|Rbar(i)-Rbar(j)| / Stdev$

Rows: Group i = 1,...,n
Columns: Group j = 1,...,n

1. Table of Z-values

Full Inflow	0.00000		*	*	*
SBIR II Inflow	2.01208	0.000000		*	*
Full Effluent	2.08498	0.072901	0.000000	*	
SBIR II Effluent	2.72652	0.714435	0.641533	0	

Adjusted for Ties in the Data

1. Table of Z-values

Full Inflow	0.00000		*	*	*
SBIR II Inflow	2.01301	0.000000		*	*
Full Effluent	2.08594	0.072935	0.000000	*	
SBIR II Effluent	2.72777	0.714764	0.641829	0	

2. Table of P-values

Full Inflow	1.00000		*	*	*
SBIR II Inflow	0.04411	1.00000		*	*
Full Effluent	0.03698	0.94186	1.00000	*	
SBIR II Effluent	0.00638	0.47475	0.52098	1	

Sign Confidence Intervals controlled at a family error rate of 0.2

Desired Confidence: 86.761

Sign confidence interval for median

	N	Median	Achieved Confidence	Confidence Interval		Position
				Lower	Upper	
Full Inflow	12	42.8	0.8540	22.0	81.2	4
			0.8676	21.8	82.0	NLI
			0.9614	16.6	100.0	3
SBIR II Inflow	12	19.97	0.8540	11.41	28.53	4
			0.8676	11.15	29.84	NLI
			0.9614	5.71	57.05	3
Full Effluent	12	16.50	0.8540	9.30	25.00	4
			0.8676	9.28	25.40	NLI
			0.9614	8.90	33.71	3
SBIR II Effluent	12	12.20	0.8540	9.66	22.81	4
			0.8676	9.50	23.02	NLI
			0.9614	6.21	27.29	3

Kruskal-Wallis: Conclusions

The following groups showed significant differences (adjusted for ties):

Groups	Z vs. Critical value	P-value
Full Inflow vs. SBIR II Effluent	2.72777 >= 2.128	0.0064

Appendix B.4.d: Kruskal-Wallis Multiple Comparison for the 12~30 μm Solids Concentration

Kruskal-Wallis: Multiple Comparisons

Kruskal-Wallis Test on the data

Group	N	Median	Ave Rank	Z
Full Inflow	12	52.685	39.5	4.29
SBIR II Inflow	12	7.403	19.8	-1.36
Full Effluent	12	11.197	24.7	0.05
SBIR II Effluent	12	4.156	14.1	-2.98
Overall	48		24.5	

H = 21.80 DF = 3 P = 0.000
H = 21.82 DF = 3 P = 0.000 (adjusted for ties)

Kruskal-Wallis: All Pairwise Comparisons

Comparisons: 6
Ties: 8
Family Alpha: 0.2
Bonferroni Individual Alpha: 0.033
Bonferroni Z-value (2-sided): 2.128

Standardized Absolute Mean Rank Differences
 $|\bar{R}(i) - \bar{R}(j)| / \text{Stdev}$

Rows: Group i = 1, ..., n
Columns: Group j = 1, ..., n

1. Table of Z-values

Full Inflow	0.00000		*	*	*
SBIR II Inflow	3.45553	0.000000		*	*
Full Effluent	2.59529	0.860237	0.00000		*
SBIR II Effluent	4.44699	0.991460	1.85170	0	

Adjusted for Ties in the Data

1. Table of Z-values

Full Inflow	0.00000		*	*	*
SBIR II Inflow	3.45703	0.000000		*	*
Full Effluent	2.59642	0.860611	0.00000		*
SBIR II Effluent	4.44892	0.991891	1.85250	0	

2. Table of P-values

Full Inflow	1.00000		*	*	*
SBIR II Inflow	0.00055	1.00000		*	*
Full Effluent	0.00942	0.38945	1.00000		*
SBIR II Effluent	0.00001	0.32125	0.06395	1	

Sign Confidence Intervals controlled at a family error rate of 0.2

Desired Confidence: 86.761

Sign confidence interval for median

	N	Median	Achieved Confidence	Confidence Interval		Position
				Lower	Upper	
Full Inflow	12	52.7	0.8540	26.0	100.3	4
			0.8676	25.7	101.7	NLI
			0.9614	19.0	130.0	3
SBIR II Inflow	12	7.40	0.8540	4.23	10.58	4
			0.8676	4.13	11.06	NLI
			0.9614	2.12	21.15	3
Full Effluent	12	11.20	0.8540	4.00	20.00	4
			0.8676	3.99	20.69	NLI
			0.9614	3.70	35.00	3
SBIR II Effluent	12	4.156	0.8540	2.759	6.147	4
			0.8676	2.754	6.177	NLI
			0.9614	2.643	6.794	3

Kruskal-Wallis: Conclusions

The following groups showed significant differences (adjusted for ties):

Groups	Z vs. Critical value	P-value
Full Inflow vs. SBIR II Effluent	4.44892 >= 2.128	0.0000
Full Inflow vs. SBIR II Inflow	3.45703 >= 2.128	0.0005
Full Inflow vs. Full Effluent	2.59642 >= 2.128	0.0094

Appendix B.4.e: Kruskal-Wallis Multiple Comparison for the 30~60 μm Solids Concentration

Kruskal-Wallis: Multiple Comparisons

Kruskal-Wallis Test on the data

Group	N	Median	Ave Rank	Z
Full Inflow	12	27.820	36.5	3.42
SBIR II Inflow	12	21.262	33.3	2.50
Full Effluent	12	4.200	21.2	-0.94
SBIR II Effluent	12	1.215	7.1	-4.98
Overall	48		24.5	

H = 32.68 DF = 3 P = 0.000
H = 32.71 DF = 3 P = 0.000 (adjusted for ties)

Kruskal-Wallis: All Pairwise Comparisons

Comparisons: 6
Ties: 9
Family Alpha: 0.2
Bonferroni Individual Alpha: 0.033
Bonferroni Z-value (2-sided): 2.128

Standardized Absolute Mean Rank Differences
 $|\bar{R}(i) - \bar{R}(j)| / \text{Stdev}$

Rows: Group i = 1, ..., n
Columns: Group j = 1, ..., n

1. Table of Z-values

Full Inflow	0.00000		*	*	*
SBIR II Inflow	0.56134	0.00000		*	*
Full Effluent	2.66819	2.10685	0.00000		*
SBIR II Effluent	5.13955	4.57821	2.47136	0	

Adjusted for Ties in the Data

1. Table of Z-values

Full Inflow	0.00000		*	*	*
SBIR II Inflow	0.56160	0.00000		*	*
Full Effluent	2.66943	2.10783	0.00000		*
SBIR II Effluent	5.14193	4.58033	2.47250	0	

2. Table of P-values

Full Inflow	1.00000		*	*	*
SBIR II Inflow	0.57439	1.00000		*	*
Full Effluent	0.00760	0.03505	1.00000		*
SBIR II Effluent	0.00000	0.00000	0.01342	1	

Sign Confidence Intervals controlled at a family error rate of 0.2

Desired Confidence: 86.761

Sign confidence interval for median

	N	Median	Achieved Confidence	Confidence Interval		Position
				Lower	Upper	
Full Inflow	12	27.82	0.8540	14.00	52.63	4
			0.8676	13.81	53.29	NLI
			0.9614	9.98	67.00	3
SBIR II Inflow	12	21.26	0.8540	12.15	30.38	4
			0.8676	11.87	31.78	NLI
			0.9614	6.08	60.75	3
Full Effluent	12	4.20	0.8540	2.10	9.00	4
			0.8676	2.08	9.28	NLI
			0.9614	1.69	15.00	3
SBIR II Effluent	12	1.215	0.8540	0.934	1.378	4
			0.8676	0.934	1.387	NLI
			0.9614	0.934	1.570	3

Kruskal-Wallis: Conclusions

The following groups showed significant differences (adjusted for ties):

Groups	Z vs. Critical value	P-value
Full Inflow vs. SBIR II Effluent	5.14193 >= 2.128	0.0000
SBIR II Inflow vs. SBIR II Effluent	4.58033 >= 2.128	0.0000
Full Inflow vs. Full Effluent	2.66943 >= 2.128	0.0076
Full Effluent vs. SBIR II Effluent	2.47250 >= 2.128	0.0134

Appendix B.4.f: Kruskal-Wallis Multiple Comparison for the 60~120 µm Solids Concentration

Kruskal-Wallis: Multiple Comparisons

Kruskal-Wallis Test on the data

Group	N	Median	Ave Rank	Z
Full Inflow	12	3.3975	29.8	1.50
SBIR II Inflow	12	15.5400	41.0	4.71
Full Effluent	12	0.7266	16.5	-2.29
SBIR II Effluent	12	0.5155	10.8	-3.93
Overall	48		24.5	

H = 33.85 DF = 3 P = 0.000
H = 33.88 DF = 3 P = 0.000 (adjusted for ties)

Kruskal-Wallis: All Pairwise Comparisons

Comparisons: 6
Ties: 11
Family Alpha: 0.2
Bonferroni Individual Alpha: 0.033
Bonferroni Z-value (2-sided): 2.128

Standardized Absolute Mean Rank Differences
 $|R_{bar}(i) - R_{bar}(j)| / Stdev$

Rows: Group i = 1, ..., n
Columns: Group j = 1, ..., n

1. Table of Z-values

Full Inflow	0.00000		*	*	*
SBIR II Inflow	1.96834	0.00000		*	*
Full Effluent	2.31827	4.28661	0.00000		*
SBIR II Effluent	3.32431	5.29265	1.00604	0	

Adjusted for Ties in the Data

1. Table of Z-values

Full Inflow	0.00000		*	*	*
SBIR II Inflow	1.96936	0.00000		*	*
Full Effluent	2.31946	4.28882	0.00000		*
SBIR II Effluent	3.32602	5.29538	1.00656	0	

2. Table of P-values

Full Inflow	1.00000		*	*	*
SBIR II Inflow	0.04891	1.00000		*	*
Full Effluent	0.02037	0.00002	1.00000		*
SBIR II Effluent	0.00088	0.00000	0.31415	1	

Sign Confidence Intervals controlled at a family error rate of 0.2

Desired Confidence: 86.761

Sign confidence interval for median

	N	Median	Achieved Confidence	Confidence Interval		Position
				Lower	Upper	
Full Inflow	12	3.398	0.8540	1.700	6.440	4
			0.8676	1.682	6.521	NLI
			0.9614	1.300	8.200	3
SBIR II Inflow	12	15.54	0.8540	8.88	22.20	4
			0.8676	8.68	23.22	NLI
			0.9614	4.44	44.40	3
Full Effluent	12	0.727	0.8540	0.570	1.400	4
			0.8676	0.560	1.400	NLI
			0.9614	0.360	1.400	3
SBIR II Effluent	12	0.5155	0.8540	0.2449	0.6193	4
			0.8676	0.2365	0.6198	NLI
			0.9614	0.0616	0.6308	3

Kruskal-Wallis: Conclusions

The following groups showed significant differences (adjusted for ties):

Groups	Z vs. Critical value	P-value
SBIR II Inflow vs. SBIR II Effluent	5.29538 >= 2.128	0.0000
SBIR II Inflow vs. Full Effluent	4.28882 >= 2.128	0.0000
Full Inflow vs. SBIR II Effluent	3.32602 >= 2.128	0.0009
Full Inflow vs. Full Effluent	2.31946 >= 2.128	0.0204

Appendix B.4.g: Kruskal-Wallis Multiple Comparison for the 120~250 μm Solids Concentration

Kruskal-Wallis: Multiple Comparisons

Kruskal-Wallis Test on the data

Group	N	Median	Ave Rank	Z
Full Inflow	12	1.752944926	33.6	2.60
SBIR II Inflow	12	2.800000000	36.8	3.50
Full Effluent	12	0.088533500	16.5	-2.29
SBIR II Effluent	12	0.000000000	11.2	-3.81
Overall	48		24.5	

H = 29.04 DF = 3 P = 0.000

H = 29.33 DF = 3 P = 0.000 (adjusted for ties)

Kruskal-Wallis: All Pairwise Comparisons

Comparisons: 6
 Ties: 17
 Family Alpha: 0.2
 Bonferroni Individual Alpha: 0.033
 Bonferroni Z-value (2-sided): 2.128

Standardized Absolute Mean Rank Differences

$|\bar{R}(i) - \bar{R}(j)| / \text{Stdev}$

Rows: Group i = 1, ..., n

Columns: Group j = 1, ..., n

1. Table of Z-values

Full Inflow	0.00000	*	*	*
SBIR II Inflow	0.55405	0.00000	*	*
Full Effluent	2.98896	3.54301	0.000000	*
SBIR II Effluent	3.92210	4.47615	0.933139	0

Adjusted for Ties in the Data

1. Table of Z-values

Full Inflow	0.00000	*	*	*
SBIR II Inflow	0.55679	0.00000	*	*
Full Effluent	3.00375	3.56054	0.000000	*
SBIR II Effluent	3.94151	4.49830	0.937757	0

2. Table of P-values

Full Inflow	1.00000	*	*	*
SBIR II Inflow	0.57767	1.00000	*	*
Full Effluent	0.00267	0.00037	1.00000	*
SBIR II Effluent	0.00008	0.00001	0.34837	1

Sign Confidence Intervals controlled at a family error rate of 0.2

Desired Confidence: 86.761

Sign confidence interval for median

	N	Median	Confidence Interval		Position
			Achieved Confidence	Lower Upper	
Full Inflow	12	1.753	0.8540	0.860 3.307	4
			0.8676	0.850 3.348	NLI
			0.9614	0.639 4.200	3
SBIR II Inflow	12	2.800	0.8540	1.600 4.000	4
			0.8676	1.563 4.185	NLI
			0.9614	0.800 8.000	3
Full Effluent	12	0.0885	0.8540	0.0430 0.1476	4
			0.8676	0.0426 0.1477	NLI
			0.9614	0.0350 0.1500	3
SBIR II Effluent	12	0.00000	0.8540	0.00000 0.00000	4
			0.8676	0.00000 0.00000	NLI
			0.9614	0.00000 0.00000	3

Kruskal-Wallis: Conclusions

The following groups showed significant differences (adjusted for ties):

Groups	Z vs. Critical value	P-value
SBIR II Inflow vs. SBIR II Effluent	4.49830 >= 2.128	0.0000
Full Inflow vs. SBIR II Effluent	3.94151 >= 2.128	0.0001
SBIR II Inflow vs. Full Effluent	3.56054 >= 2.128	0.0004
Full Inflow vs. Full Effluent	3.00375 >= 2.128	0.0027

Appendix B.4.h: Kruskal-Wallis Multiple Comparison for the >250 µm Solids Concentration

Kruskal-Wallis: Multiple Comparisons

Kruskal-Wallis Test on the data

Group	N	Median	Ave Rank	Z
Full Inflow	12	2.45684E+01	32.8	2.36
SBIR II Inflow	12	8.80250E+01	40.3	4.50
Full Effluent	12	0.000000000	12.5	-3.43
SBIR II Effluent	12	0.000000000	12.5	-3.43
Overall	48		24.5	

H = 36.99 DF = 3 P = 0.000

H = 42.31 DF = 3 P = 0.000 (adjusted for ties)

Kruskal-Wallis: All Pairwise Comparisons

Comparisons: 6
Ties: 31
Family Alpha: 0.2
Bonferroni Individual Alpha: 0.033
Bonferroni Z-value (2-sided): 2.128

Standardized Absolute Mean Rank Differences
 $|Rbar(i)-Rbar(j)| / Stdev$

Rows: Group i = 1,...,n
Columns: Group j = 1,...,n

1. Table of Z-values

Full Inflow	0.00000		*	*	*
SBIR II Inflow	1.31223	0.00000	*	*	*
Full Effluent	3.54301	4.85524	0	*	
SBIR II Effluent	3.54301	4.85524	0	0	

Adjusted for Ties in the Data

1. Table of Z-values

Full Inflow	0.00000		*	*	*
SBIR II Inflow	1.40340	0.00000	*	*	*
Full Effluent	3.78917	5.19256	0	*	
SBIR II Effluent	3.78917	5.19256	0	0	

2. Table of P-values

Full Inflow	1.00000		*	*	*
SBIR II Inflow	0.16050	1.00000	*	*	*
Full Effluent	0.00015	0.00000	1	*	
SBIR II Effluent	0.00015	0.00000	1	1	

Sign Confidence Intervals controlled at a family error rate of 0.2

Desired Confidence: 86.761

Sign confidence interval for median

	N	Median	Achieved Confidence	Confidence Interval		Position
				Lower	Upper	
Full Inflow	12	24.57	0.8540	12.50	45.86	4
			0.8676	12.36	46.70	NLI
			0.9614	9.41	64.00	3
SBIR II Inflow	12	88.0	0.8540	50.3	125.8	4
			0.8676	49.1	131.6	NLI
			0.9614	25.2	251.5	3
Full Effluent	12	0.00000	0.8540	0.00000	0.00000	4
			0.8676	0.00000	0.00000	NLI
			0.9614	0.00000	0.00000	3
SBIR II Effluent	12	0.00000	0.8540	0.00000	0.00000	4
			0.8676	0.00000	0.00000	NLI
			0.9614	0.00000	0.00000	3

Kruskal-Wallis: Conclusions

The following groups showed significant differences (adjusted for ties):

Groups	Z vs. Critical value	P-value
SBIR II Inflow vs. Full Effluent	5.19256 >= 2.128	0.0000
SBIR II Inflow vs. SBIR II Effluent	5.19256 >= 2.128	0.0000
Full Inflow vs. Full Effluent	3.78917 >= 2.128	0.0002
Full Inflow vs. SBIR II Effluent	3.78917 >= 2.128	0.0002

Appendix C.1: Kruskal-Wallis Multiple Comparison for the <0.45 µm Solids Concentration

Kruskal-Wallis: Multiple Comparisons

Kruskal-Wallis Test on the data

Group	N	Median	Ave Rank	Z
Full Inflow	20	106.00000	64.5	5.71
SBIR II Inflow	19	0.03450	21.9	-3.88
Full Effluent	20	72.48333	52.5	2.99
SBIR II Effluent	19	0.01290	17.1	-4.96
Overall	78		39.5	

H = 60.92 DF = 3 P = 0.000
H = 60.93 DF = 3 P = 0.000 (adjusted for ties)

Kruskal-Wallis: All Pairwise Comparisons

Comparisons: 6
Ties: 6
Family Alpha: 0.2
Bonferroni Individual Alpha: 0.033
Bonferroni Z-value (2-sided): 2.128

Standardized Absolute Mean Rank Differences
 $|Rbar(i)-Rbar(j)| / Stdev$

Rows: Group i = 1,...,n
Columns: Group j = 1,...,n

1. Table of Z-values

Full Inflow	0.00000		*	*	*
SBIR II Inflow	5.85471	0.00000		*	*
Full Effluent	1.66064	4.21549	0.00000		*
SBIR II Effluent	6.52895	0.66576	4.88974	0	

Adjusted for Ties in the Data

1. Table of Z-values

Full Inflow	0.00000		*	*	*
SBIR II Inflow	5.85493	0.00000		*	*
Full Effluent	1.66071	4.21565	0.00000		*
SBIR II Effluent	6.52920	0.66579	4.88992	0	

2. Table of P-values

Full Inflow	1.00000		*	*	*
SBIR II Inflow	0.00000	1.00000		*	*
Full Effluent	0.09677	0.00002	1.00000		*
SBIR II Effluent	0.00000	0.50555	0.00000	1	

Sign Confidence Intervals controlled at a family error rate of 0.2

Desired Confidence: 86.761

Sign confidence interval for median

	N	Median	Achieved Confidence	Confidence Interval		Position
				Lower	Upper	
Full Inflow	20	106.0	0.7368	92.0	119.0	8
			0.8676	91.8	119.8	NLI
			0.8847	91.8	120.0	7
SBIR II Inflow	19	0.03450	0.8329	0.00710	0.05500	7
			0.8676	0.00696	0.05500	NLI
			0.9364	0.00638	0.05500	6
Full Effluent	20	72.48	0.7368	60.80	77.50	8
			0.8676	55.46	78.87	NLI
			0.8847	54.17	79.20	7
SBIR II Effluent	19	0.01290	0.8329	0.00660	0.02160	7
			0.8676	0.00603	0.02317	NLI
			0.9364	0.00360	0.02990	6

Kruskal-Wallis: Conclusions

The following groups showed significant differences (adjusted for ties):

Groups	Z vs. Critical value	P-value
Full Inflow vs. SBIR II Effluent	6.52920 >= 2.128	0
Full Inflow vs. SBIR II Inflow	5.85493 >= 2.128	0
Full Effluent vs. SBIR II Effluent	4.88992 >= 2.128	0
SBIR II Inflow vs. Full Effluent	4.21565 >= 2.128	0

Appendix C.2: Kruskal-Wallis Multiple Comparison for the 0.45~3 µm Solids Concentration

Kruskal-Wallis: Multiple Comparisons

Kruskal-Wallis Test on the data

Group	N	Median	Ave Rank	Z
Full Inflow	20	0.6414	42.1	-0.29
SBIR II Inflow	23	1.7120	55.0	2.59
Full Effluent	20	0.3138	32.7	-2.21
SBIR II Effluent	23	0.5993	42.6	-0.21
Overall	86		43.5	

H = 8.75 DF = 3 P = 0.033
H = 8.75 DF = 3 P = 0.033 (adjusted for ties)

Kruskal-Wallis: All Pairwise Comparisons

Comparisons: 6
Ties: 2
Family Alpha: 0.2
Bonferroni Individual Alpha: 0.033
Bonferroni Z-value (2-sided): 2.128

Standardized Absolute Mean Rank Differences
 $|\bar{R}(i) - \bar{R}(j)| / \text{Stdev}$

Rows: Group i = 1, ..., n
Columns: Group j = 1, ..., n

1. Table of Z-values

Full Inflow	0.00000		*	*	*
SBIR II Inflow	1.69542	0.00000		*	*
Full Effluent	1.19045	2.92669	0.00000		*
SBIR II Effluent	0.06094	1.69467	1.29221	0	

Adjusted for Ties in the Data

1. Table of Z-values

Full Inflow	0.00000		*	*	*
SBIR II Inflow	1.69545	0.00000		*	*
Full Effluent	1.19047	2.92675	0.00000		*
SBIR II Effluent	0.06094	1.69470	1.29223	0	

2. Table of P-values

Full Inflow	1.00000		*	*	*
SBIR II Inflow	0.08999	1.00000		*	*
Full Effluent	0.23386	0.00343	1.00000		*
SBIR II Effluent	0.95141	0.09013	0.19628	1	

Sign Confidence Intervals controlled at a family error rate of 0.2

Desired Confidence: 86.761

Sign confidence interval for median

	N	Median	Achieved Confidence	Confidence Interval		Position
				Lower	Upper	
Full Inflow	20	0.6414	0.7368	0.2888	0.8283	8
			0.8676	0.2751	0.9455	NLI
			0.8847	0.2718	0.9739	7
SBIR II Inflow	23	1.712	0.7900	0.620	2.276	9
			0.8676	0.475	2.716	NLI
			0.9069	0.337	3.133	8
Full Effluent	20	0.3138	0.7368	0.1818	0.4032	8
			0.8676	0.1260	0.7586	NLI
			0.8847	0.1124	0.8447	7
SBIR II Effluent	23	0.599	0.7900	0.311	0.960	9
			0.8676	0.249	1.139	NLI
			0.9069	0.190	1.309	8

Kruskal-Wallis: Conclusions

The following groups showed significant differences (adjusted for ties):

Groups	Z vs. Critical value	P-value
SBIR II Inflow vs. Full Effluent	2.92675 >= 2.128	0.0034

Appendix C.3: Kruskal-Wallis Multiple Comparison for the 3~12 µm Solids Concentration

Kruskal-Wallis: Multiple Comparisons

Kruskal-Wallis Test on the data

Group	N	Median	Ave Rank	Z
Full Inflow	20	5.025	56.8	2.71
SBIR II Inflow	23	3.280	46.0	0.56
Full Effluent	20	1.557	37.6	-1.20
SBIR II Effluent	23	1.330	34.6	-2.00
Overall	86		43.5	

H = 9.90 DF = 3 P = 0.019
H = 9.91 DF = 3 P = 0.019 (adjusted for ties)

Kruskal-Wallis: All Pairwise Comparisons

Comparisons: 6
Ties: 3
Family Alpha: 0.2
Bonferroni Individual Alpha: 0.033
Bonferroni Z-value (2-sided): 2.128

Standardized Absolute Mean Rank Differences
 $|\bar{R}(i) - \bar{R}(j)| / \text{Stdev}$

Rows: Group i = 1, ..., n
Columns: Group j = 1, ..., n

1. Table of Z-values

Full Inflow	0.00000		*	*	*
SBIR II Inflow	1.40810	0.00000		*	*
Full Effluent	2.41888	1.09374	0.000000		*
SBIR II Effluent	2.90591	1.55295	0.404065	0	

Adjusted for Ties in the Data

1. Table of Z-values

Full Inflow	0.00000		*	*	*
SBIR II Inflow	1.40814	0.00000		*	*
Full Effluent	2.41894	1.09376	0.000000		*
SBIR II Effluent	2.90598	1.55299	0.404074	0	

2. Table of P-values

Full Inflow	1.00000		*	*	*
SBIR II Inflow	0.15909	1.00000		*	*
Full Effluent	0.01557	0.27406	1.00000		*
SBIR II Effluent	0.00366	0.12043	0.68616	1	

Sign Confidence Intervals controlled at a family error rate of 0.2

Desired Confidence: 86.761

Sign confidence interval for median

	N	Median	Achieved Confidence	Confidence Interval		Position
				Lower	Upper	
Full Inflow	20	5.025	0.7368	3.750	6.127	8
			0.8676	3.531	6.214	NLI
			0.8847	3.478	6.235	7
SBIR II Inflow	23	3.280	0.7900	2.020	5.320	9
			0.8676	1.697	5.366	NLI
			0.9069	1.390	5.410	8
Full Effluent	20	1.557	0.7368	1.074	1.958	8
			0.8676	1.004	2.322	NLI
			0.8847	0.987	2.410	7
SBIR II Effluent	23	1.330	0.7900	0.617	2.360	9
			0.8676	0.567	2.576	NLI
			0.9069	0.519	2.780	8

Kruskal-Wallis: Conclusions

The following groups showed significant differences (adjusted for ties):

Groups	Z vs. Critical value	P-value
Full Inflow vs. SBIR II Effluent	2.90598 >= 2.128	0.0037
Full Inflow vs. Full Effluent	2.41894 >= 2.128	0.0156

Appendix C.4: Kruskal-Wallis Multiple Comparison for the 12~30 µm Solids Concentration

Kruskal-Wallis: Multiple Comparisons

Kruskal-Wallis Test on the data

Group	N	Median	Ave Rank	Z
Full Inflow	20	7.411	60.9	3.55
SBIR II Inflow	23	3.970	46.0	0.57
Full Effluent	20	2.473	34.9	-1.77
SBIR II Effluent	23	2.135	33.4	-2.27
Overall	86		43.5	

H = 16.06 DF = 3 P = 0.001
H = 16.06 DF = 3 P = 0.001 (adjusted for ties)

Kruskal-Wallis: All Pairwise Comparisons

Comparisons: 6
Ties: 2
Family Alpha: 0.2
Bonferroni Individual Alpha: 0.033
Bonferroni Z-value (2-sided): 2.128

Standardized Absolute Mean Rank Differences
 $|Rbar(i)-Rbar(j)| / Stdev$

Rows: Group i = 1,...,n
Columns: Group j = 1,...,n

1. Table of Z-values

Full Inflow	0.00000		*	*	*
SBIR II Inflow	1.93945	0.00000		*	*
Full Effluent	3.29272	1.46619	0.000000		*
SBIR II Effluent	3.59672	1.71829	0.191069	0	

Adjusted for Ties in the Data

1. Table of Z-values

Full Inflow	0.00000		*	*	*
SBIR II Inflow	1.93949	0.00000		*	*
Full Effluent	3.29278	1.46622	0.000000		*
SBIR II Effluent	3.59679	1.71832	0.191073	0	

2. Table of P-values

Full Inflow	1.00000		*	*	*
SBIR II Inflow	0.05244	1.00000		*	*
Full Effluent	0.00099	0.14259	1.00000		*
SBIR II Effluent	0.00032	0.08574	0.84847	1	

Sign Confidence Intervals controlled at a family error rate of 0.2

Desired Confidence: 86.761

Sign confidence interval for median

	N	Median	Achieved Confidence	Confidence Interval		Position
				Lower	Upper	
Full Inflow	20	7.41	0.7368	6.57	11.60	8
			0.8676	5.89	11.99	NLI
			0.8847	5.72	12.08	7
SBIR II Inflow	23	3.970	0.7900	2.910	6.950	9
			0.8676	2.854	7.104	NLI
			0.9069	2.800	7.250	8
Full Effluent	20	2.473	0.7368	1.580	2.956	8
			0.8676	1.341	3.139	NLI
			0.8847	1.284	3.184	7
SBIR II Effluent	23	2.135	0.7900	1.040	3.630	9
			0.8676	0.927	3.719	NLI
			0.9069	0.820	3.804	8

Kruskal-Wallis: Conclusions

The following groups showed significant differences (adjusted for ties):

Groups	Z vs. Critical value	P-value
Full Inflow vs. SBIR II Effluent	3.59679 >= 2.128	0.0003
Full Inflow vs. Full Effluent	3.29278 >= 2.128	0.0010

Appendix C.5: Kruskal-Wallis Multiple Comparison for the 30~60 µm Solids Concentration

Kruskal-Wallis: Multiple Comparisons

Kruskal-Wallis Test on the data

Group	N	Median	Ave Rank	Z
Full Inflow	20	15.287	64.0	4.18
SBIR II Inflow	23	4.588	43.7	0.04
Full Effluent	20	4.563	40.6	-0.58
SBIR II Effluent	23	1.777	28.0	-3.48
Overall	86		43.5	

H = 22.54 DF = 3 P = 0.000
H = 22.54 DF = 3 P = 0.000 (adjusted for ties)

Kruskal-Wallis: All Pairwise Comparisons

Comparisons: 6
Ties: 1
Family Alpha: 0.2
Bonferroni Individual Alpha: 0.033
Bonferroni Z-value (2-sided): 2.128

Standardized Absolute Mean Rank Differences
 $|Rbar(i)-Rbar(j)| / Stdev$

Rows: Group i = 1,...,n
Columns: Group j = 1,...,n

1. Table of Z-values

Full Inflow	0.00000		*	*	*
SBIR II Inflow	2.65305	0.00000		*	*
Full Effluent	2.95079	0.39894	0.00000		*
SBIR II Effluent	4.70896	2.13162	1.65698	0	

Adjusted for Ties in the Data

1. Table of Z-values

Full Inflow	0.00000		*	*	*
SBIR II Inflow	2.65306	0.00000		*	*
Full Effluent	2.95080	0.39894	0.00000		*
SBIR II Effluent	4.70899	2.13163	1.65699	0	

2. Table of P-values

Full Inflow	1.00000		*	*	*
SBIR II Inflow	0.00798	1.00000		*	*
Full Effluent	0.00317	0.68994	1.00000		*
SBIR II Effluent	0.00000	0.03304	0.09752	1	

Sign Confidence Intervals controlled at a family error rate of 0.2

Desired Confidence: 86.761

Sign confidence interval for median

	N	Median	Achieved Confidence	Confidence Interval		Position
				Lower	Upper	
Full Inflow	20	15.29	0.7368	11.21	20.39	8
			0.8676	9.11	21.18	NLI
			0.8847	8.60	21.37	7
SBIR II Inflow	23	4.588	0.7900	2.789	6.871	9
			0.8676	2.466	7.858	NLI
			0.9069	2.159	8.794	8
Full Effluent	20	4.563	0.7368	3.240	5.575	8
			0.8676	3.157	5.594	NLI
			0.8847	3.136	5.599	7
SBIR II Effluent	23	1.777	0.7900	0.961	3.670	9
			0.8676	0.949	3.757	NLI
			0.9069	0.937	3.839	8

Kruskal-Wallis: Conclusions

The following groups showed significant differences (adjusted for ties):

Groups	Z vs. Critical value	P-value
Full Inflow vs. SBIR II Effluent	4.70899 >= 2.128	0.0000
Full Inflow vs. Full Effluent	2.95080 >= 2.128	0.0032
Full Inflow vs. SBIR II Inflow	2.65306 >= 2.128	0.0080
SBIR II Inflow vs. SBIR II Effluent	2.13163 >= 2.128	0.0330

Appendix C.6: Kruskal-Wallis Multiple Comparison for the 60~120 μm Solids Concentration

Kruskal-Wallis: Multiple Comparisons

Kruskal-Wallis Test on the data

Group	N	Median	Ave Rank	Z
Full Inflow	20	12.6291	66.5	5.41
SBIR II Inflow	21	1.0523	34.3	-1.60
Full Effluent	20	2.5139	43.0	0.31
SBIR II Effluent	21	0.4410	23.4	-4.03
Overall	82		41.5	

H = 36.20 DF = 3 P = 0.000
H = 36.20 DF = 3 P = 0.000 (adjusted for ties)

Kruskal-Wallis: All Pairwise Comparisons

Comparisons: 6
Ties: 3
Family Alpha: 0.2
Bonferroni Individual Alpha: 0.033
Bonferroni Z-value (2-sided): 2.128

Standardized Absolute Mean Rank Differences
 $|\bar{R}(i) - \bar{R}(j)| / \text{Stdev}$

Rows: Group i = 1, ..., n
Columns: Group j = 1, ..., n

1. Table of Z-values

Full Inflow	0.00000		*	*	*
SBIR II Inflow	4.32970	0.00000		*	*
Full Effluent	3.13369	1.15802	0.00000		*
SBIR II Effluent	5.79523	1.48373	2.62355	0	

Adjusted for Ties in the Data

1. Table of Z-values

Full Inflow	0.00000		*	*	*
SBIR II Inflow	4.32994	0.00000		*	*
Full Effluent	3.13387	1.15808	0.00000		*
SBIR II Effluent	5.79554	1.48381	2.62369	0	

2. Table of P-values

Full Inflow	1.00000		*	*	*
SBIR II Inflow	0.00001	1.00000		*	*
Full Effluent	0.00173	0.24683	1.00000		*
SBIR II Effluent	0.00000	0.13786	0.00870	1	

Sign Confidence Intervals controlled at a family error rate of 0.2

Desired Confidence: 86.761

Sign confidence interval for median

	N	Median	Achieved Confidence	Confidence Interval		Position
				Lower	Upper	
Full Inflow	20	12.63	0.7368	8.74	17.53	8
			0.8676	7.65	17.64	NLI
			0.8847	7.38	17.66	7
SBIR II Inflow	21	1.052	0.8108	0.643	1.373	8
			0.8676	0.635	1.921	NLI
			0.9216	0.620	2.961	7
Full Effluent	20	2.514	0.7368	2.090	3.390	8
			0.8676	2.011	4.048	NLI
			0.8847	1.991	4.207	7
SBIR II Effluent	21	0.441	0.8108	0.194	1.055	8
			0.8676	0.187	1.203	NLI
			0.9216	0.173	1.485	7

Kruskal-Wallis: Conclusions

The following groups showed significant differences (adjusted for ties):

Groups	Z vs. Critical value	P-value
Full Inflow vs. SBIR II Effluent	5.79554 >= 2.128	0.0000
Full Inflow vs. SBIR II Inflow	4.32994 >= 2.128	0.0000
Full Inflow vs. Full Effluent	3.13387 >= 2.128	0.0017
Full Effluent vs. SBIR II Effluent	2.62369 >= 2.128	0.0087

Appendix D.1: Kruskal-Wallis Multiple Comparison for the Turbidity

Kruskal-Wallis: Multiple Comparisons

Kruskal-Wallis Test on the data

Group	N	Median	Ave Rank	Z
Full Inflow	20	15.550	56.6	2.42
SBIR II Inflow	24	13.150	50.5	1.35
Full Effluent	20	7.155	32.4	-2.41
SBIR II Effluent	24	7.140	38.4	-1.36
Overall	88		44.5	

H = 11.69 DF = 3 P = 0.009
H = 11.70 DF = 3 P = 0.009 (adjusted for ties)

Kruskal-Wallis: All Pairwise Comparisons

Comparisons: 6
Ties: 3
Family Alpha: 0.2
Bonferroni Individual Alpha: 0.033
Bonferroni Z-value (2-sided): 2.128

Standardized Absolute Mean Rank Differences
 $|R_{bar}(i) - R_{bar}(j)| / Stdev$

Rows: Group i = 1, ..., n
Columns: Group j = 1, ..., n

1. Table of Z-values

Full Inflow	0.00000		*	*	*
SBIR II Inflow	0.79241	0.00000		*	*
Full Effluent	3.00169	2.34275	0.000000		*
SBIR II Effluent	2.35461	1.63844	0.780559	0	

Adjusted for Ties in the Data

1. Table of Z-values

Full Inflow	0.00000		*	*	*
SBIR II Inflow	0.79242	0.00000		*	*
Full Effluent	3.00173	2.34279	0.000000		*
SBIR II Effluent	2.35464	1.63847	0.780569	0	

2. Table of P-values

Full Inflow	1.00000		*	*	*
SBIR II Inflow	0.42812	1.00000		*	*
Full Effluent	0.00268	0.01914	1.00000		*
SBIR II Effluent	0.01854	0.10132	0.43506	1	

Sign Confidence Intervals controlled at a family error rate of 0.2

Desired Confidence: 86.761

Sign confidence interval for median

	N	Median	Achieved Confidence	Confidence Interval		Position
				Lower	Upper	
Full Inflow	20	15.55	0.7368	12.10	18.90	8
			0.8676	10.41	19.79	NLI
			0.8847	10.00	20.00	7
SBIR II Inflow	24	13.15	0.8484	7.51	19.30	9
			0.8676	7.39	19.69	NLI
			0.9361	6.51	22.50	8
			0.7368	7.010	7.540	8
Full Effluent	20	7.155	0.8676	6.117	7.854	NLI
			0.8847	5.900	7.930	7
			0.8484	5.92	9.98	9
SBIR II Effluent	24	7.14	0.8676	5.83	10.06	NLI
			0.9361	5.21	10.60	8

Kruskal-Wallis: Conclusions

The following groups showed significant differences (adjusted for ties):

Groups	Z vs. Critical value	P-value
Full Inflow vs. Full Effluent	3.00173 >= 2.128	0.0027
Full Inflow vs. SBIR II Effluent	2.35464 >= 2.128	0.0185
SBIR II Inflow vs. Full Effluent	2.34279 >= 2.128	0.0191

Appendix D.2: Kruskal-Wallis Multiple Comparison for the COD

Kruskal-Wallis: Multiple Comparisons

Kruskal-Wallis Test on the data

Group	N	Median	Ave Rank	Z
Full Inflow	20	24.50	39.8	-0.94
SBIR II Inflow	24	61.50	58.1	3.06
Full Effluent	20	14.00	25.6	-3.77
SBIR II Effluent	24	40.50	50.6	1.37
Overall	88		44.5	

H = 19.86 DF = 3 P = 0.000
H = 19.87 DF = 3 P = 0.000 (adjusted for ties)

Kruskal-Wallis: All Pairwise Comparisons

Comparisons: 6
Ties: 31
Family Alpha: 0.2
Bonferroni Individual Alpha: 0.033
Bonferroni Z-value (2-sided): 2.128

Standardized Absolute Mean Rank Differences
 $|R_{bar}(i) - R_{bar}(j)| / Stdev$

Rows: Group i = 1, ..., n
Columns: Group j = 1, ..., n

1. Table of Z-values

Full Inflow	0.00000		*	*	*
SBIR II Inflow	2.36646	0.00000		*	*
Full Effluent	1.76388	4.20877	0.00000		*
SBIR II Effluent	1.39682	1.01697	3.23913	0	

Adjusted for Ties in the Data

1. Table of Z-values

Full Inflow	0.00000		*	*	*
SBIR II Inflow	2.36708	0.00000		*	*
Full Effluent	1.76435	4.20988	0.00000		*
SBIR II Effluent	1.39719	1.01723	3.23999	0	

2. Table of P-values

Full Inflow	1.00000		*	*	*
SBIR II Inflow	0.01793	1.00000		*	*
Full Effluent	0.07767	0.00003	1.00000		*
SBIR II Effluent	0.16236	0.30904	0.00120	1	

Sign Confidence Intervals controlled at a family error rate of 0.2

Desired Confidence: 86.761

Sign confidence interval for median

	N	Median	Achieved Confidence	Confidence Interval		Position
				Lower	Upper	
Full Inflow	20	24.50	0.7368	17.00	45.00	8
			0.8676	14.59	66.73	NLI
			0.8847	14.00	72.00	7
SBIR II Inflow	24	61.50	0.8484	38.00	79.00	9
			0.8676	37.88	80.23	NLI
			0.9361	37.00	89.00	8
			0.7368	10.00	19.00	8
Full Effluent	20	14.00	0.8676	8.39	22.22	NLI
			0.8847	8.00	23.00	7
			0.8484	32.00	68.00	9
SBIR II Effluent	24	40.50	0.8676	31.14	68.86	NLI
			0.9361	25.00	75.00	8

Kruskal-Wallis: Conclusions

The following groups showed significant differences (adjusted for ties):

Groups	Z vs. Critical value	P-value
SBIR II Inflow vs. Full Effluent	4.20988 >= 2.128	0.0000
Full Effluent vs. SBIR II Effluent	3.23999 >= 2.128	0.0012
Full Inflow vs. SBIR II Inflow	2.36708 >= 2.128	0.0179

Appendix D.3: Kruskal-Wallis Multiple Comparison for the Phosphorus

Kruskal-Wallis: Multiple Comparisons

Kruskal-Wallis Test on the data

Group	N	Median	Ave Rank	Z
Full Inflow	20	1.2150	62.3	3.54
SBIR II Inflow	24	0.6100	38.3	-1.40
Full Effluent	20	0.8450	51.1	1.31
SBIR II Effluent	24	0.4350	30.4	-3.18
Overall	88		44.5	

H = 19.80 DF = 3 P = 0.000
H = 19.80 DF = 3 P = 0.000 (adjusted for ties)

Kruskal-Wallis: All Pairwise Comparisons

Comparisons: 6
Ties: 20
Family Alpha: 0.2
Bonferroni Individual Alpha: 0.033
Bonferroni Z-value (2-sided): 2.128

Standardized Absolute Mean Rank Differences
 $|\bar{R}(i) - \bar{R}(j)| / \text{Stdev}$

Rows: Group i = 1, ..., n
Columns: Group j = 1, ..., n

1. Table of Z-values

Full Inflow	0.00000		*	*	*
SBIR II Inflow	3.10392	0.00000		*	*
Full Effluent	1.38635	1.65593	0.00000		*
SBIR II Effluent	4.12743	1.07346	2.67943	0	

Adjusted for Ties in the Data

1. Table of Z-values

Full Inflow	0.00000		*	*	*
SBIR II Inflow	3.10428	0.00000		*	*
Full Effluent	1.38651	1.65612	0.00000		*
SBIR II Effluent	4.12790	1.07359	2.67974	0	

2. Table of P-values

Full Inflow	1.00000		*	*	*
SBIR II Inflow	0.00191	1.00000		*	*
Full Effluent	0.16559	0.09770	1.00000		*
SBIR II Effluent	0.00004	0.28301	0.00737	1	

Sign Confidence Intervals controlled at a family error rate of 0.2

Desired Confidence: 86.761

Sign confidence interval for median

	N	Median	Achieved Confidence	Confidence Interval		Position
				Lower	Upper	
Full Inflow	20	1.215	0.7368	0.860	1.340	8
			0.8676	0.828	1.557	NLI
			0.8847	0.820	1.610	7
SBIR II Inflow	24	0.6100	0.8484	0.3500	0.7600	9
			0.8676	0.3451	0.7600	NLI
			0.9361	0.3100	0.7600	8
Full Effluent	20	0.8450	0.7368	0.7200	0.9000	8
			0.8676	0.6959	0.9644	NLI
			0.8847	0.6900	0.9800	7
SBIR II Effluent	24	0.4350	0.8484	0.2800	0.6000	9
			0.8676	0.2763	0.6037	NLI
			0.9361	0.2500	0.6300	8

Kruskal-Wallis: Conclusions

The following groups showed significant differences (adjusted for ties):

Groups	Z vs. Critical value	P-value
Full Inflow vs. SBIR II Effluent	4.12790 >= 2.128	0.0000
Full Inflow vs. SBIR II Inflow	3.10428 >= 2.128	0.0019
Full Effluent vs. SBIR II Effluent	2.67974 >= 2.128	0.0074

Appendix D.4: Kruskal-Wallis Multiple Comparison for the Nitrate

Kruskal-Wallis: Multiple Comparisons

Kruskal-Wallis Test on the data

Group	N	Median	Ave Rank	Z
Full Inflow	20	0.8000	63.3	3.73
SBIR II Inflow	24	0.4000	35.3	-2.06
Full Effluent	20	0.6500	49.0	0.90
SBIR II Effluent	24	0.4000	34.3	-2.30
Overall	88		44.5	

H = 18.32 DF = 3 P = 0.000
H = 18.55 DF = 3 P = 0.000 (adjusted for ties)

Kruskal-Wallis: All Pairwise Comparisons

Comparisons: 6
Ties: 64
Family Alpha: 0.2
Bonferroni Individual Alpha: 0.033
Bonferroni Z-value (2-sided): 2.128

Standardized Absolute Mean Rank Differences
 $|\bar{R}(i) - \bar{R}(j)| / \text{Stdev}$

Rows: Group i = 1, ..., n
Columns: Group j = 1, ..., n

1. Table of Z-values

Full Inflow	0.00000		*	*	*
SBIR II Inflow	3.60921	0.00000		*	*
Full Effluent	1.76388	1.76690	0.00000		*
SBIR II Effluent	3.74388	0.14125	1.90157	0	

Adjusted for Ties in the Data

1. Table of Z-values

Full Inflow	0.00000		*	*	*
SBIR II Inflow	3.63189	0.00000		*	*
Full Effluent	1.77497	1.77800	0.00000		*
SBIR II Effluent	3.76741	0.14213	1.91352	0	

2. Table of P-values

Full Inflow	1.00000		*	*	*
SBIR II Inflow	0.00028	1.00000		*	*
Full Effluent	0.07590	0.07540	1.00000		*
SBIR II Effluent	0.00016	0.88698	0.05568	1	

Sign Confidence Intervals controlled at a family error rate of 0.2

Desired Confidence: 86.761

Sign confidence interval for median

	N	Median	Achieved Confidence	Confidence Interval		Position
				Lower	Upper	
Full Inflow	20	0.8000	0.7368	0.7000	0.9000	8
			0.8676	0.7000	0.9000	NLI
			0.8847	0.7000	0.9000	7
SBIR II Inflow	24	0.4000	0.8484	0.3000	0.5000	9
			0.8676	0.3000	0.5000	NLI
			0.9361	0.3000	0.5000	8
Full Effluent	20	0.6500	0.7368	0.5000	0.7000	8
			0.8676	0.5000	0.7000	NLI
			0.8847	0.5000	0.7000	7
SBIR II Effluent	24	0.4000	0.8484	0.3000	0.5000	9
			0.8676	0.2877	0.5000	NLI
			0.9361	0.2000	0.5000	8

Kruskal-Wallis: Conclusions

The following groups showed significant differences (adjusted for ties):

Groups	Z vs. Critical value	P-value
Full Inflow vs. SBIR II Effluent	3.76741 >= 2.128	0.0002
Full Inflow vs. SBIR II Inflow	3.63189 >= 2.128	0.0003

Appendix D.5: Kruskal-Wallis Multiple Comparison for the Ammonia

Kruskal-Wallis: Multiple Comparisons

Kruskal-Wallis Test on the data

Group	N	Median	Ave Rank	Z
Full Inflow	20	0.08000	43.8	-0.14
SBIR II Inflow	24	0.20500	57.9	3.02
Full Effluent	20	0.03000	21.8	-4.53
SBIR II Effluent	24	0.10500	50.6	1.37
Overall	88		44.5	

H = 23.85 DF = 3 P = 0.000
H = 23.94 DF = 3 P = 0.000 (adjusted for ties)

Kruskal-Wallis: All Pairwise Comparisons

Comparisons: 6
Ties: 49
Family Alpha: 0.2
Bonferroni Individual Alpha: 0.033
Bonferroni Z-value (2-sided): 2.128

Standardized Absolute Mean Rank Differences
 $|Rbar(i)-Rbar(j)| / Stdev$

Rows: Group i = 1,...,n
Columns: Group j = 1,...,n

1. Table of Z-values

Full Inflow	0.00000		*	*	*
SBIR II Inflow	1.83100	0.00000		*	*
Full Effluent	2.72318	4.67527	0.00000		*
SBIR II Effluent	0.88291	0.99437	3.72718	0	

Adjusted for Ties in the Data

1. Table of Z-values

Full Inflow	0.00000		*	*	*
SBIR II Inflow	1.83448	0.00000		*	*
Full Effluent	2.72835	4.68415	0.00000		*
SBIR II Effluent	0.88459	0.99625	3.73426	0	

2. Table of P-values

Full Inflow	1.00000		*	*	*
SBIR II Inflow	0.06658	1.00000		*	*
Full Effluent	0.00637	0.00000	1.00000		*
SBIR II Effluent	0.37638	0.31913	0.00019	1	

Sign Confidence Intervals controlled at a family error rate of 0.2

Desired Confidence: 86.761

Sign confidence interval for median

	N	Median	Achieved Confidence	Confidence Interval		Position
				Lower	Upper	
Full Inflow	20	0.08000	0.7368	0.06000	0.08000	8
			0.8676	0.06000	0.08805	NLI
			0.8847	0.06000	0.09000	7
SBIR II Inflow	24	0.2050	0.8484	0.1600	0.3100	9
			0.8676	0.1575	0.3297	NLI
			0.9361	0.1400	0.4700	8
Full Effluent	20	0.03000	0.7368	0.01000	0.04000	8
			0.8676	0.01000	0.04000	NLI
			0.8847	0.01000	0.04000	7
SBIR II Effluent	24	0.1050	0.8484	0.0700	0.2200	9
			0.8676	0.0675	0.2249	NLI
			0.9361	0.0500	0.2600	8

Kruskal-Wallis: Conclusions

The following groups showed significant differences (adjusted for ties):

Groups	Z vs. Critical value	P-value
SBIR II Inflow vs. Full Effluent	4.68415 >= 2.128	0.0000
Full Effluent vs. SBIR II Effluent	3.73426 >= 2.128	0.0002
Full Inflow vs. Full Effluent	2.72835 >= 2.128	0.0064

Appendix D.6: Kruskal-Wallis Multiple Comparison for the E-Coli

Kruskal-Wallis: Multiple Comparisons

Kruskal-Wallis Test on the data

Group	N	Median	Ave Rank	Z
Full Inflow	19	2230.0	45.4	0.38
SBIR II Inflow	24	3104.0	53.9	2.41
Full Effluent	19	740.0	26.0	-3.46
SBIR II Effluent	24	2228.5	45.4	0.44
Overall	86		43.5	

H = 13.76 DF = 3 P = 0.003
H = 13.76 DF = 3 P = 0.003 (adjusted for ties)

Kruskal-Wallis: All Pairwise Comparisons

Comparisons: 6
Ties: 4
Family Alpha: 0.2
Bonferroni Individual Alpha: 0.033
Bonferroni Z-value (2-sided): 2.128

Standardized Absolute Mean Rank Differences
 $|R_{bar}(i) - R_{bar}(j)| / Stdev$

Rows: Group i = 1, ..., n
Columns: Group j = 1, ..., n

1. Table of Z-values

Full Inflow	0.00000		*	*	*
SBIR II Inflow	1.10796	0.00000		*	*
Full Effluent	2.39727	3.64077	0.00000		*
SBIR II Effluent	0.00057	1.17921	2.53224	0	

Adjusted for Ties in the Data

1. Table of Z-values

Full Inflow	0.00000		*	*	*
SBIR II Inflow	1.10799	0.00000		*	*
Full Effluent	2.39733	3.64088	0.00000		*
SBIR II Effluent	0.00057	1.17924	2.53231	0	

2. Table of P-values

Full Inflow	1.00000		*	*	*
SBIR II Inflow	0.26786	1.00000		*	*
Full Effluent	0.01651	0.00027	1.00000		*
SBIR II Effluent	0.99954	0.23830	0.01133	1	

Sign Confidence Intervals controlled at a family error rate of 0.2

Desired Confidence: 86.761

Sign confidence interval for median

	N	Median	Achieved Confidence	Confidence Interval		Position
				Lower	Upper	
Full Inflow	19	2230	0.8329	1180	4170	7
			0.8676	1180	4561	NLI
			0.9364	1180	6240	6
SBIR II Inflow	24	3104	0.8484	1935	4084	9
			0.8676	1909	4514	NLI
			0.9361	1725	7580	8
			0.8329	610	1320	7
Full Effluent	19	740	0.8676	610	1326	NLI
			0.9364	610	1350	6
			0.8484	1918	2430	9
SBIR II Effluent	24	2229	0.8676	1915	2503	NLI
			0.9361	1890	3024	8

Kruskal-Wallis: Conclusions

The following groups showed significant differences (adjusted for ties):

Groups	Z vs. Critical value	P-value
SBIR II Inflow vs. Full Effluent	3.64088 >= 2.128	0.0003
Full Effluent vs. SBIR II Effluent	2.53231 >= 2.128	0.0113
Full Inflow vs. Full Effluent	2.39733 >= 2.128	0.0165

Appendix D.7: Kruskal-Wallis Multiple Comparison for the Enterococci

Kruskal-Wallis: Multiple Comparisons

Kruskal-Wallis Test on the data

Group	N	Median	Ave Rank	Z
Full Inflow	19	4410	43.1	-0.08
SBIR II Inflow	24	7662	56.5	3.01
Full Effluent	19	1790	29.6	-2.74
SBIR II Effluent	24	4906	41.8	-0.40
Overall	86		43.5	

H = 12.51 DF = 3 P = 0.006
H = 12.51 DF = 3 P = 0.006 (adjusted for ties)

Kruskal-Wallis: All Pairwise Comparisons

Comparisons: 6
Ties: 4
Family Alpha: 0.2
Bonferroni Individual Alpha: 0.033
Bonferroni Z-value (2-sided): 2.128

Standardized Absolute Mean Rank Differences
 $|R_{bar}(i) - R_{bar}(j)| / Stdev$

Rows: Group i = 1, ..., n
Columns: Group j = 1, ..., n

1. Table of Z-values

Full Inflow	0.00000		*	*	*
SBIR II Inflow	1.74960	0.00000		*	*
Full Effluent	1.66314	3.50678	0.00000		*
SBIR II Effluent	0.17403	2.04628	1.58315	0	

Adjusted for Ties in the Data

1. Table of Z-values

Full Inflow	0.00000		*	*	*
SBIR II Inflow	1.74963	0.00000		*	*
Full Effluent	1.66318	3.50685	0.00000		*
SBIR II Effluent	0.17403	2.04632	1.58318	0	

2. Table of P-values

Full Inflow	1.00000		*	*	*
SBIR II Inflow	0.08018	1.00000		*	*
Full Effluent	0.09628	0.00045	1.00000		*
SBIR II Effluent	0.86184	0.04073	0.11338	1	

Sign Confidence Intervals controlled at a family error rate of 0.2

Desired Confidence: 86.761

Sign confidence interval for median

	N	Median	Achieved Confidence	Confidence Interval		Position
				Lower	Upper	
Full Inflow	19	4410	0.8329	3500	10580	7
			0.8676	3426	10922	NLI
			0.9364	3110	12390	6
SBIR II Inflow	24	7662	0.8484	6867	9208	9
			0.8676	6838	9674	NLI
			0.9361	6628	12997	8
			0.8329	1340	9040	7
Full Effluent	19	1790	0.8676	1310	9253	NLI
			0.9364	1180	10170	6
			0.8484	4106	5944	9
SBIR II Effluent	24	4906	0.8676	4106	6063	NLI
			0.9361	4106	6910	8

Kruskal-Wallis: Conclusions

The following groups showed significant differences (adjusted for ties):

Groups	Z vs. Critical value	P-value
SBIR II Inflow vs. Full Effluent	3.50685 >= 2.128	0.0005

Appendix D.8: Kruskal-Wallis Multiple Comparison for the TSS

Kruskal-Wallis: Multiple Comparisons

Kruskal-Wallis Test on the data

Group	N	Median	Ave Rank	Z
Full Inflow	17	55.00	43.3	0.35
SBIR II Inflow	24	88.00	55.9	3.53
Full Effluent	17	16.00	13.2	-5.50
SBIR II Effluent	24	64.50	45.8	1.05
Overall	82		41.5	

H = 33.70 DF = 3 P = 0.000
H = 33.71 DF = 3 P = 0.000 (adjusted for ties)

Kruskal-Wallis: All Pairwise Comparisons

Comparisons: 6
Ties: 14
Family Alpha: 0.2
Bonferroni Individual Alpha: 0.033
Bonferroni Z-value (2-sided): 2.128

Standardized Absolute Mean Rank Differences
 $|R_{bar}(i) - R_{bar}(j)| / Stdev$

Rows: Group i = 1, ..., n
Columns: Group j = 1, ..., n

1. Table of Z-values

Full Inflow	0.00000		*	*	*
SBIR II Inflow	1.67084	0.00000		*	*
Full Effluent	3.68702	5.66020	0.00000		*
SBIR II Effluent	0.32969	1.47275	4.31905	0	

Adjusted for Ties in the Data

1. Table of Z-values

Full Inflow	0.00000		*	*	*
SBIR II Inflow	1.67107	0.00000		*	*
Full Effluent	3.68752	5.66097	0.00000		*
SBIR II Effluent	0.32973	1.47295	4.31964	0	

2. Table of P-values

Full Inflow	1.00000		*	*	*
SBIR II Inflow	0.09471	1.00000		*	*
Full Effluent	0.00023	0.00000	1.00000		*
SBIR II Effluent	0.74160	0.14076	0.00002	1	

Sign Confidence Intervals controlled at a family error rate of 0.2

Desired Confidence: 86.761

Sign confidence interval for median

	N	Median	Achieved Confidence	Confidence Interval		Position
				Lower	Upper	
Full Inflow	17	55.00	0.8565	42.00	88.00	6
			0.8676	41.90	88.10	NLI
			0.9510	40.00	90.00	5
SBIR II Inflow	24	88.0	0.8484	74.0	112.0	9
			0.8676	73.4	113.0	NLI
			0.9361	69.0	120.0	8
			0.8565	13.00	21.00	6
Full Effluent	17	16.00	0.8676	12.95	21.16	NLI
			0.9510	12.00	24.00	5
			0.8484	43.00	72.00	9
SBIR II Effluent	24	64.50	0.8676	42.51	72.37	NLI
			0.9361	39.00	75.00	8

Kruskal-Wallis: Conclusions

The following groups showed significant differences (adjusted for ties):

Groups	Z vs. Critical value	P-value
SBIR II Inflow vs. Full Effluent	5.66097 >= 2.128	0.0000
Full Effluent vs. SBIR II Effluent	4.31964 >= 2.128	0.0000
Full Inflow vs. Full Effluent	3.68752 >= 2.128	0.0002

Appendix D.9: Kruskal-Wallis Multiple Comparison for the SSC

Kruskal-Wallis: Multiple Comparisons

84 cases were used
4 cases contained missing values

Kruskal-Wallis Test on the data

Group	N	Median	Ave Rank	Z
Full Inflow	20	76.000	67.0	5.15
SBIR II Inflow	20	26.000	42.3	-0.05
Full Effluent	20	17.950	36.4	-1.28
SBIR II Effluent	24	7.000	27.3	-3.60
Overall	84		42.5	

H = 30.70 DF = 3 P = 0.000
H = 30.72 DF = 3 P = 0.000 (adjusted for ties)

Kruskal-Wallis: All Pairwise Comparisons

 Comparisons: 6
 Ties: 29
 Family Alpha: 0.2
 Bonferroni Individual Alpha: 0.033
 Bonferroni Z-value (2-sided): 2.128

Standardized Absolute Mean Rank Differences
 $|\bar{R}(i) - \bar{R}(j)| / \text{Stdev}$

Rows: Group i = 1, ..., n
 Columns: Group j = 1, ..., n

1. Table of Z-values

Full Inflow	0.00000		*	*	*
SBIR II Inflow	3.20537	0.00000		*	*
Full Effluent	3.96377	0.75840	0.00000		*
SBIR II Effluent	5.37108	2.02318	1.23106	0	

 Adjusted for Ties in the Data

1. Table of Z-values

Full Inflow	0.00000		*	*	*
SBIR II Inflow	3.20642	0.00000		*	*
Full Effluent	3.96507	0.75865	0.00000		*
SBIR II Effluent	5.37285	2.02385	1.23147	0	

2. Table of P-values

Full Inflow	1.00000		*	*	*
SBIR II Inflow	0.00134	1.00000		*	*
Full Effluent	0.00007	0.44806	1.00000		*

SBIR II Effluent 0.00000 0.04299 0.21815 1

Sign Confidence Intervals controlled at a family error rate of 0.2

Desired Confidence: 86.761

Sign confidence interval for median

	N	N*	Median	Confidence Interval			Position
				Achieved Confidence	Lower	Upper	
Full Inflow	20	0	76.00	0.7368	53.60	87.00	8
				0.8676	52.31	93.04	NLI
				0.8847	52.00	94.50	7
SBIR II Inflow	20	4	26.00	0.7368	17.00	41.00	8
				0.8676	15.39	42.61	NLI
				0.8847	15.00	43.00	7
Full Effluent	20	0	17.95	0.7368	14.70	21.10	8
				0.8676	12.20	21.58	NLI
				0.8847	11.60	21.70	7
SBIR II Effluent	24	0	7.00	0.8484	4.00	17.00	9
				0.8676	3.88	17.12	NLI
				0.9361	3.00	18.00	8

Kruskal-Wallis: Conclusions

The following groups showed significant differences (adjusted for ties):

Groups	Z vs. Critical value	P-value
Full Inflow vs. SBIR II Effluent	5.37285 >= 2.128	0.0000
Full Inflow vs. Full Effluent	3.96507 >= 2.128	0.0001
Full Inflow vs. SBIR II Inflow	3.20642 >= 2.128	0.0013

Appendix E.1: Kruskal-Wallis Multiple Comparison for the TSS

Kruskal-Wallis: Multiple Comparisons

Kruskal-Wallis Test on the data

Group	N	Median	Ave Rank	Z
Full-Scale	20	76.00	127.3	0.49
SBIR II	24	19.00	59.4	-4.53
NSQD AL	70	48.50	104.3	-2.26
NSQD Rain Zoon 3	125	82.36	139.3	4.51
Overall	239		120.0	

H = 31.97 DF = 3 P = 0.000
H = 31.98 DF = 3 P = 0.000 (adjusted for ties)

Kruskal-Wallis: All Pairwise Comparisons

Comparisons: 6
Ties: 95
Family Alpha: 0.2
Bonferroni Individual Alpha: 0.033
Bonferroni Z-value (2-sided): 2.128

Standardized Absolute Mean Rank Differences
 $|R_{bar}(i) - R_{bar}(j)| / Stdev$

Rows: Group i = 1, ..., n
Columns: Group j = 1, ..., n

1. Table of Z-values

Full-Scale	0.00000		*	*	*
SBIR II	3.24516	0.00000		*	*
NSQD AL	1.31350	2.74577	0.00000		*
NSQD Rain Zoon 3	0.71655	5.18303	3.38684	0	

Adjusted for Ties in the Data

1. Table of Z-values

Full-Scale	0.00000		*	*	*
SBIR II	3.24538	0.00000		*	*
NSQD AL	1.31358	2.74595	0.00000		*
NSQD Rain Zoon 3	0.71660	5.18338	3.38707	0	

2. Table of P-values

Full-Scale	1.00000		*	*	*
SBIR II	0.00117	1.00000		*	*
NSQD AL	0.18899	0.00603	1.00000		*
NSQD Rain Zoon 3	0.47362	0.00000	0.00071	1	

Sign Confidence Intervals controlled at a family error rate of 0.2

Desired Confidence: 86.761

Sign confidence interval for median

	N	Median	Confidence		Position
			Achieved	Interval	
Full-Scale	20	76.00	0.7368	53.60 87.00	8
			0.8676	52.31 93.04	NLI
			0.8847	52.00 94.50	7
SBIR II	24	19.00	0.8484	15.00 29.00	9
			0.8676	14.51 30.48	NLI
			0.9361	11.00 41.00	8
NSQD AL	70	48.50	0.8114	38.00 60.00	30
			0.8676	32.64 60.77	NLI
			0.8798	31.00 61.00	29
NSQD Rain Zoon 3	125	82.4	0.8476	73.0 110.0	55
			0.8676	71.9 110.0	NLI
			0.8926	70.0 110.0	54

Kruskal-Wallis: Conclusions

The following groups showed significant differences (adjusted for ties):

Groups	Z vs. Critical value	P-value
SBIR II vs. NSQD Rain Zoon 3	5.18338 >= 2.128	0.0000
NSQD AL vs. NSQD Rain Zoon 3	3.38707 >= 2.128	0.0007
Full-Scale vs. SBIR II	3.24538 >= 2.128	0.0012
SBIR II vs. NSQD AL	2.74595 >= 2.128	0.0060

Appendix E.2: Kruskal-Wallis Multiple Comparison for the Rain Depth

Kruskal-Wallis: Multiple Comparisons

Kruskal-Wallis Test on the data

Group	N	Median	Ave Rank	Z
Full-Scale	20	0.7100	194.9	-1.45
SBIR II	31	0.5200	185.6	-2.22
NSQD AL	34	0.5200	220.8	-0.78
NSQD Rain Zoon 3	391	0.7400	246.5	2.71
Overall	476		238.5	

H = 8.47 DF = 3 P = 0.037
H = 8.47 DF = 3 P = 0.037 (adjusted for ties)

Kruskal-Wallis: All Pairwise Comparisons

Comparisons: 6
Ties: 238
Family Alpha: 0.2
Bonferroni Individual Alpha: 0.033
Bonferroni Z-value (2-sided): 2.128

Standardized Absolute Mean Rank Differences
 $|Rbar(i)-Rbar(j)| / Stdev$

Rows: Group i = 1,...,n
Columns: Group j = 1,...,n

1. Table of Z-values

Full-Scale	0.00000		*	*	*
SBIR II	0.23559	0.00000		*	*
NSQD AL	0.66980	1.03215	0.00000		*
NSQD Rain Zoon 3	1.63591	2.37209	1.04188	0	

Adjusted for Ties in the Data

1. Table of Z-values

Full-Scale	0.00000		*	*	*
SBIR II	0.23560	0.00000		*	*
NSQD AL	0.66981	1.03217	0.00000		*
NSQD Rain Zoon 3	1.63594	2.37214	1.04191	0	

2. Table of P-values

Full-Scale	1.00000		*	*	*
SBIR II	0.81375	1.00000		*	*
NSQD AL	0.50298	0.30199	1.00000		*
NSQD Rain Zoon 3	0.10185	0.01769	0.29746	1	

Sign Confidence Intervals controlled at a family error rate of 0.2

Desired Confidence: 86.761

Sign confidence interval for median

	N	Median	Confidence			Position
			Achieved Confidence	Lower Interval	Upper Interval	
Full-Scale	20	0.7100	0.7368	0.5100	0.7800	8
			0.8676	0.3812	0.7961	NLI
			0.8847	0.3500	0.8000	7
SBIR II	31	0.5200	0.8504	0.2600	0.6100	12
			0.8676	0.2547	0.6140	NLI
			0.9292	0.2200	0.6400	11
NSQD AL	34	0.5200	0.7705	0.3600	0.9000	14
			0.8676	0.3262	0.9000	NLI
			0.8786	0.3200	0.9000	13
NSQD Rain Zoon 3	391	0.7400	0.8432	0.7090	0.7800	182
			0.8676	0.7020	0.7800	NLI
			0.8708	0.7010	0.7800	181

Kruskal-Wallis: Conclusions

The following groups showed significant differences (adjusted for ties):

Groups	Z vs. Critical value	P-value
SBIR II vs. NSQD Rain Zoon 3	2.37214 >= 2.128	0.0177

Appendix F.1: Kruskal-Wallis Multiple Comparison for the July 16, 2010 Turbidity

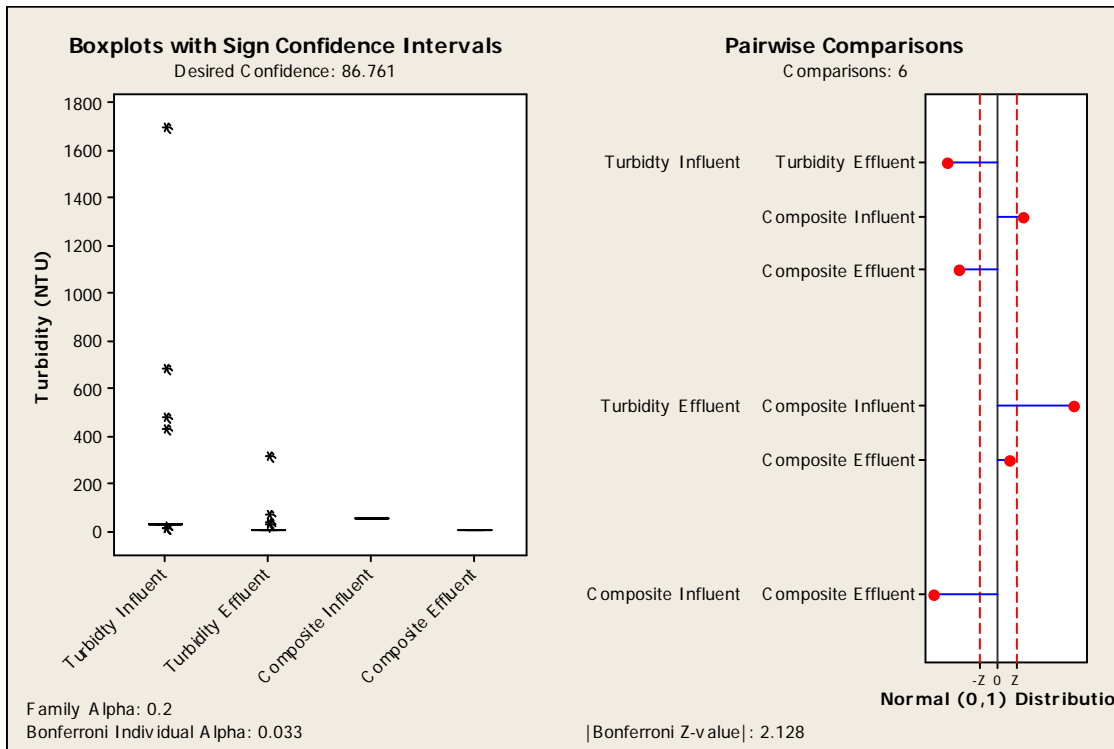
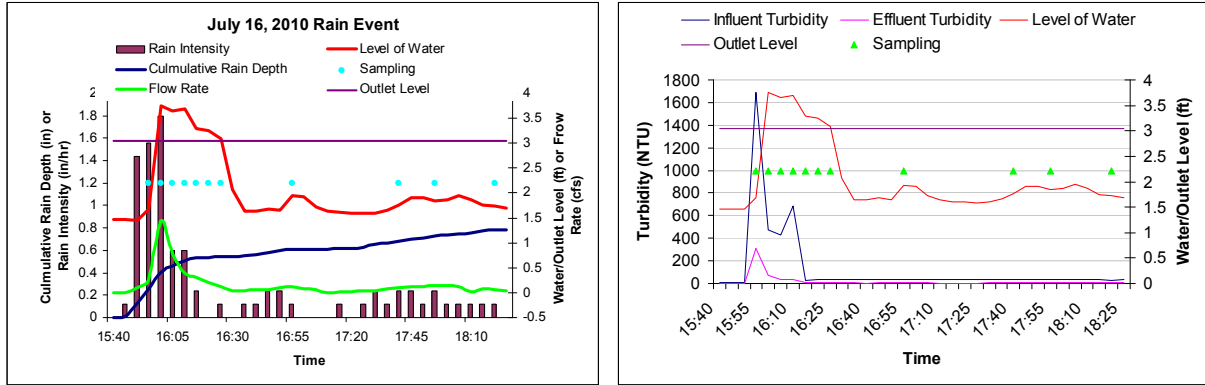

Kruskal-Wallis: Multiple Comparisons

135 cases were used
1 cases contained missing values

Kruskal-Wallis Test on the data

Group	N	Median	Ave Rank	Z
Turbidity Influent	34	34.150	85.7	3.05

Turbidity Effluent	33	5.900	30.2	-6.39
Composite Influent	34	55.800	112.5	7.67
Composite Effluent	34	7.500	42.5	-4.39
Overall	135		68.0	

H = 96.27 DF = 3 P = 0.000
H = 99.45 DF = 3 P = 0.000 (adjusted for ties)

Kruskal-Wallis: All Pairwise Comparisons

Comparisons:	6
Ties:	77
Family Alpha:	0.2
Bonferroni Individual Alpha:	0.033
Bonferroni Z-value (2-sided):	2.128

Standardized Absolute Mean Rank Differences
 $|\bar{R}(i) - \bar{R}(j)| / \text{Stdev}$

Rows: Group i = 1, ..., n
Columns: Group j = 1, ..., n

1. Table of Z-values

Turbidity Influent	0.00000		*	*	*
Turbidity Effluent	5.80891	0.00000		*	*
Composite Influent	2.82435	8.61210	0.00000		*
Composite Effluent	4.55430	1.28872	7.37865	0	

Adjusted for Ties in the Data

1. Table of Z-values

Turbidity Influent	0.00000		*	*	*
Turbidity Effluent	5.90401	0.00000		*	*
Composite Influent	2.87059	8.75309	0.00000		*
Composite Effluent	4.62886	1.30982	7.49944	0	

2. Table of P-values

Turbidity Influent	1.00000		*	*	*
Turbidity Effluent	0.00000	1.00000		*	*
Composite Influent	0.00410	0.00000	1.00000		*
Composite Effluent	0.00000	0.19026	0.00000	1	

Sign Confidence Intervals controlled at a family error rate of 0.2

Desired Confidence: 86.761

Sign confidence interval for median

Confidence

	N	N*	Median	Achieved Confidence	Interval		Position
					Lower	Upper	
Turbidity Influent	34	0	34.15	0.7705	33.90	34.40	14
				0.8676	33.39	34.48	NLI
				0.8786	33.30	34.50	13
Turbidity Effluent	33	1	5.900	0.8372	5.400	6.900	13
				0.8676	5.375	6.950	NLI
				0.9199	5.300	7.100	12
Composite Influent	34	0	55.80	0.7705	55.80	55.80	14
				0.8676	55.80	55.80	NLI
				0.8786	55.80	55.80	13
Composite Effluent	34	0	7.500	0.7705	7.500	7.500	14
				0.8676	7.500	7.500	NLI
				0.8786	7.500	7.500	13

Kruskal-Wallis: Conclusions

The following groups showed significant differences (adjusted for ties):

Groups	Z vs. Critical value
Turbidity Effluent vs. Composite Influent	8.75309 >= 2.128
Composite Influent vs. Composite Effluent	7.49944 >= 2.128
Turbidity Influent vs. Turbidity Effluent	5.90401 >= 2.128
Turbidity Influent vs. Composite Effluent	4.62886 >= 2.128
Turbidity Influent vs. Composite Influent	2.87059 >= 2.128

P-value
0.0000
0.0000
0.0000
0.0000
0.0041

Appendix F.2: Kruskal-Wallis Multiple Comparison for the September 26, 2010 Turbidity

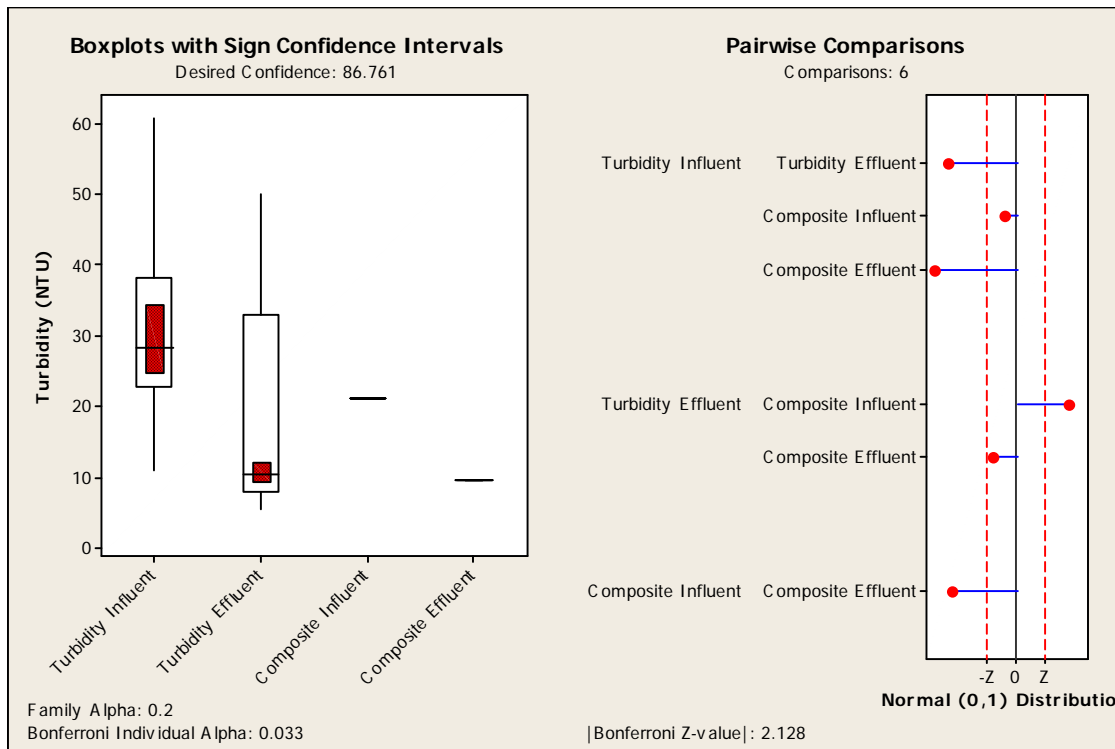
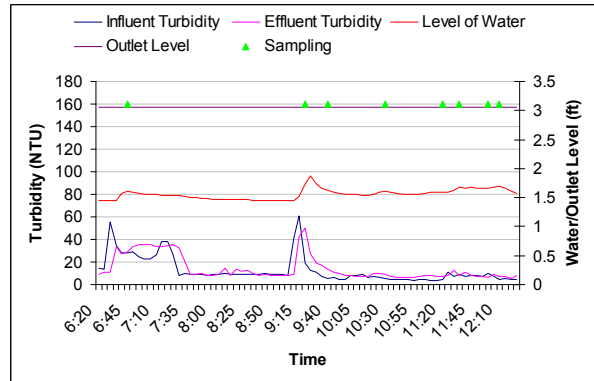
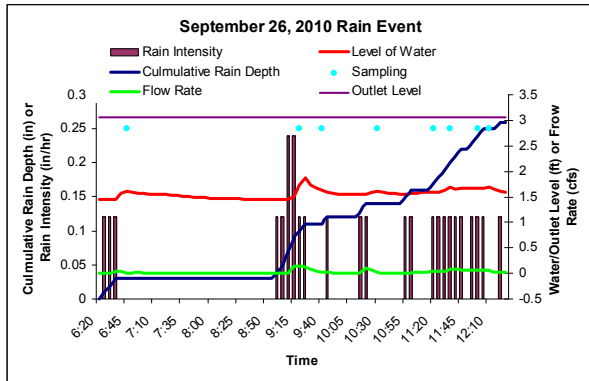

Kruskal-Wallis: Multiple Comparisons

Kruskal-Wallis Test on the data

Group	N	Median	Ave Rank	Z
Turbidity Influent	17	28.300	182.2	5.19
Turbidity Effluent	90	10.300	103.4	-0.83
Composite Influent	17	21.200	163.0	3.85
Composite Effluent	90	9.500	87.0	-4.13
Overall	214		107.5	

H = 48.68 DF = 3 P = 0.000

H = 52.77 DF = 3 P = 0.000 (adjusted for ties)

Kruskal-Wallis: All Pairwise Comparisons

```
-----
Comparisons:                6
Ties:                        146
Family Alpha:                0.2
Bonferroni Individual Alpha: 0.033
Bonferroni Z-value (2-sided): 2.128
-----
```

Standardized Absolute Mean Rank Differences
 $|\bar{R}(i) - \bar{R}(j)| / \text{Stdev}$

Rows: Group i = 1, ..., n
 Columns: Group j = 1, ..., n

1. Table of Z-values

```
-----
Turbidity Influent  0.00000      *      *      *
Turbidity Effluent  4.81437  0.00000      *      *
Composite Influent  0.90568  3.63969  0.00000  *
Composite Effluent  5.81589  1.77670  4.64122  0
-----
```

Adjusted for Ties in the Data

1. Table of Z-values

```
-----
Turbidity Influent  0.00000      *      *      *
Turbidity Effluent  5.01233  0.00000      *      *
Composite Influent  0.94292  3.78935  0.00000  *
Composite Effluent  6.05504  1.84976  4.83206  0
-----
```

2. Table of P-values

```
-----
Turbidity Influent  1.00000      *      *      *
Turbidity Effluent  0.00000  1.00000      *      *
Composite Influent  0.34572  0.00015  1.00000  *
Composite Effluent  0.00000  0.06435  0.00000  1
-----
```

Sign Confidence Intervals controlled at a family error rate of 0.2

Desired Confidence: 86.761

Sign confidence interval for median

	N	Median	Achieved Confidence	Confidence Interval		Position
				Lower	Upper	
Turbidity Influent	17	28.30	0.8565	24.90	34.20	6
			0.8676	24.80	34.40	NLI
			0.9510	22.90	38.00	5
Turbidity Effluent	90	10.30	0.8294	9.20	11.70	39
			0.8676	9.20	12.18	NLI
			0.8862	9.20	12.50	38

Composite Influent	17	21.20	0.8565	21.20	21.20	6
			0.8676	21.20	21.20	NLI
			0.9510	21.20	21.20	5
Composite Effluent	90	9.500	0.8294	9.500	9.500	39
			0.8676	9.500	9.500	NLI
			0.8862	9.500	9.500	38

Kruskal-Wallis: Conclusions

The following groups showed significant differences (adjusted for ties):

Groups	Z vs. Critical value
Turbidity Influent vs. Composite Effluent	6.05504 >= 2.128
Turbidity Influent vs. Turbidity Effluent	5.01233 >= 2.128
Composite Influent vs. Composite Effluent	4.83206 >= 2.128
Turbidity Effluent vs. Composite Influent	3.78935 >= 2.128

P-value
0.0000
0.0000
0.0000
0.0002

Appendix F.3: Kruskal-Wallis Multiple Comparison for the October 12, 2010 Turbidity

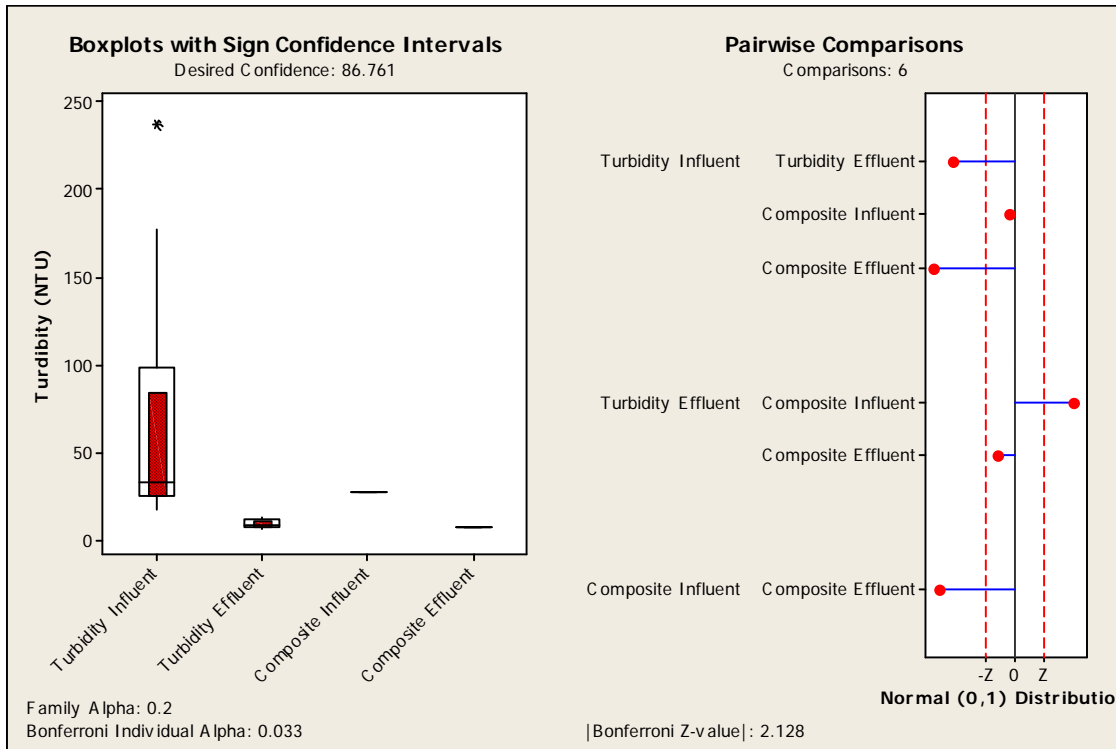
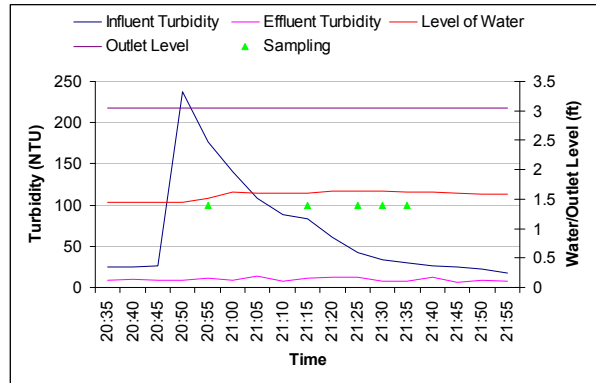
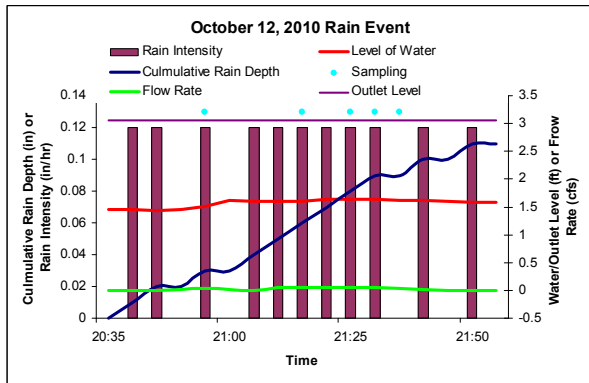

Kruskal-Wallis: Multiple Comparisons

Kruskal-Wallis Test on the data

Group	N	Median	Ave Rank	Z
Turbidity Influent	17	33.500	53.0	4.45
Turbidity Effluent	17	8.800	22.0	-3.01
Composite Influent	17	27.800	50.0	3.73
Composite Effluent	17	7.900	13.0	-5.18
Overall	68		34.5	

H = 52.22 DF = 3 P = 0.000
H = 53.90 DF = 3 P = 0.000 (adjusted for ties)

Kruskal-Wallis: All Pairwise Comparisons

Comparisons: 6
Ties: 33
Family Alpha: 0.2
Bonferroni Individual Alpha: 0.033
Bonferroni Z-value (2-sided): 2.128

Standardized Absolute Mean Rank Differences
 $|\bar{R}(i) - \bar{R}(j)| / \text{Stdev}$

Rows: Group i = 1, ..., n
Columns: Group j = 1, ..., n

1. Table of Z-values

Turbidity Influent	0.00000		*	*	*
Turbidity Effluent	4.57070	0.00000		*	*
Composite Influent	0.44233	4.12837	0.00000	*	
Composite Effluent	5.89768	1.32698	5.45535	0	

Adjusted for Ties in the Data

1. Table of Z-values

Turbidity Influent	0.00000		*	*	*
Turbidity Effluent	4.64364	0.00000		*	*
Composite Influent	0.44938	4.19425	0.00000	*	
Composite Effluent	5.99179	1.34815	5.54241	0	

2. Table of P-values

Turbidity Influent	1.00000		*	*	*
Turbidity Effluent	0.00000	1.00000		*	*
Composite Influent	0.65315	0.00003	1.00000	*	
Composite Effluent	0.00000	0.17761	0.00000	1	

Sign Confidence Intervals controlled at a family error rate of 0.2

Desired Confidence: 86.761

Sign confidence interval for median

	N	Median	Achieved Confidence	Confidence Interval		Position
				Lower	Upper	
Turbidity Influent	17	33.50	0.8565	25.90	83.90	6
			0.8676	25.87	84.10	NLI
			0.9510	25.40	87.80	5

Turbidity Effluent	17	8.80	0.8565	8.20	11.30	6
			0.8676	8.19	11.32	NLI
			0.9510	8.00	11.60	5
Composite Influent	17	27.80	0.8565	27.80	27.80	6
			0.8676	27.80	27.80	NLI
			0.9510	27.80	27.80	5
Composite Effluent	17	7.900	0.8565	7.900	7.900	6
			0.8676	7.900	7.900	NLI
			0.9510	7.900	7.900	5

Kruskal-Wallis: Conclusions

The following groups showed significant differences (adjusted for ties):

Groups	Z vs. Critical value
Turbidity Influent vs. Composite Effluent	5.99179 >= 2.128
Composite Influent vs. Composite Effluent	5.54241 >= 2.128
Turbidity Influent vs. Turbidity Effluent	4.64364 >= 2.128
Turbidity Effluent vs. Composite Influent	4.19425 >= 2.128

P-value

0
0
0
0

Appendix F.4: Kruskal-Wallis Multiple Comparison for the October 25, 2010 Turbidity

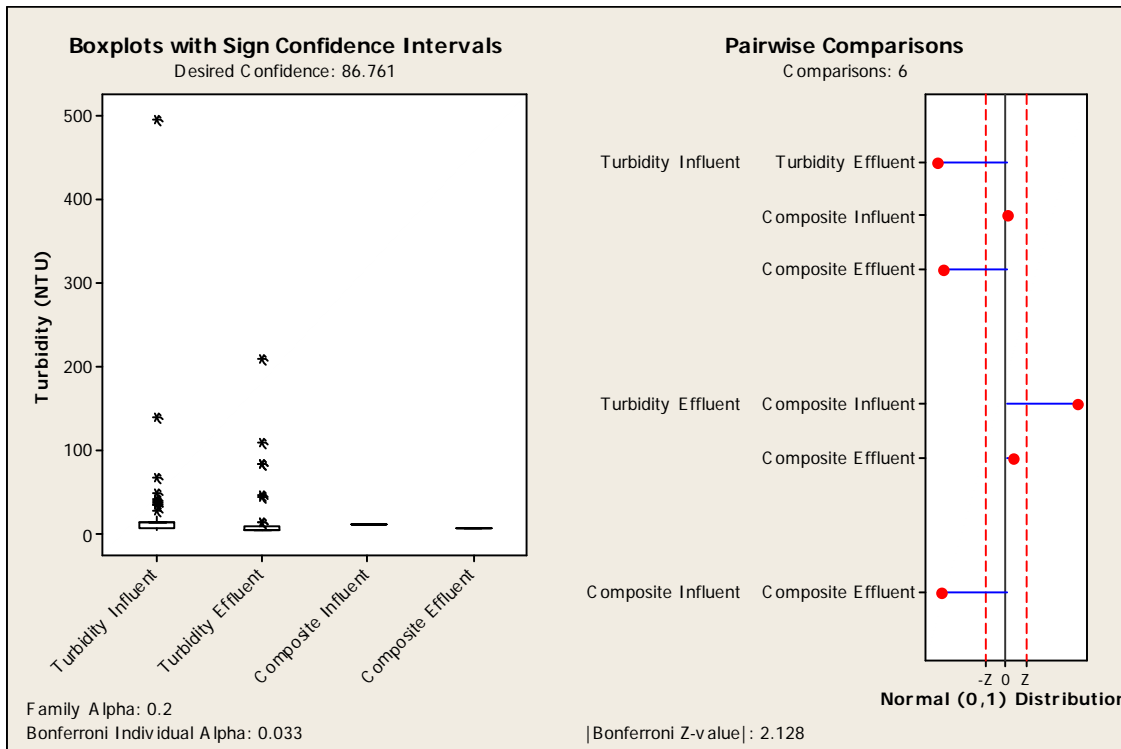
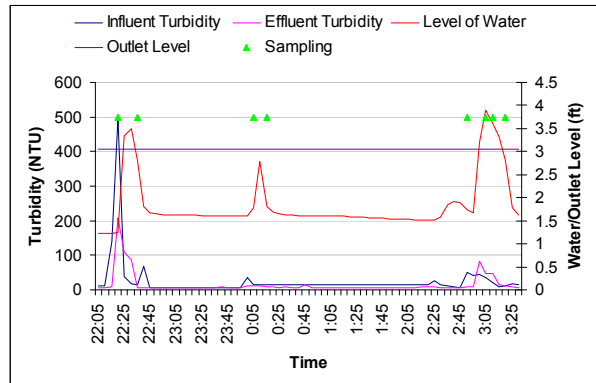
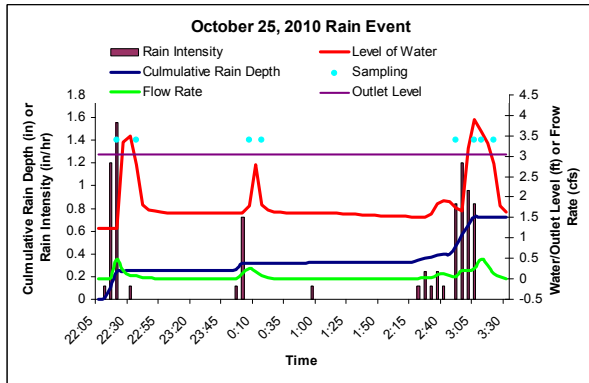

Kruskal-Wallis: Multiple Comparisons

Kruskal-Wallis Test on the data

Group	N	Median	Ave Rank	Z
Turbidity Influent	66	14.750	176.2	5.36
Turbidity Effluent	66	6.700	83.3	-6.04
Composite Influent	66	12.400	178.5	5.65
Composite Effluent	66	7.100	92.0	-4.98
Overall	264		132.5	

H = 91.44 DF = 3 P = 0.000
H = 94.49 DF = 3 P = 0.000 (adjusted for ties)

Kruskal-Wallis: All Pairwise Comparisons

Comparisons: 6
Ties: 194
Family Alpha: 0.2
Bonferroni Individual Alpha: 0.033
Bonferroni Z-value (2-sided): 2.128

Standardized Absolute Mean Rank Differences
|Rbar(i)-Rbar(j)| / Stdev

Rows: Group i = 1,...,n
Columns: Group j = 1,...,n

1. Table of Z-values

Turbidity Influent	0.00000		*	*	*
Turbidity Effluent	6.98208	0.00000		*	*
Composite Influent	0.17669	7.15877	0.00000	*	
Composite Effluent	6.33118	0.65090	6.50787	0	

Adjusted for Ties in the Data

1. Table of Z-values

Turbidity Influent	0.00000		*	*	*
Turbidity Effluent	7.09735	0.00000		*	*
Composite Influent	0.17961	7.27695	0.00000	*	
Composite Effluent	6.43570	0.66165	6.61531	0	

2. Table of P-values

Turbidity Influent	1.00000		*	*	*
Turbidity Effluent	0.00000	1.00000		*	*
Composite Influent	0.85746	0.00000	1.00000	*	
Composite Effluent	0.00000	0.50820	0.00000	1	

Sign Confidence Intervals controlled at a family error rate of 0.2

Desired Confidence: 86.761

Sign confidence interval for median

	N	Median	Achieved Confidence	Confidence Interval		Position
				Lower	Upper	
Turbidity Influent	66	14.75	0.8243	14.40	14.90	28
			0.8676	14.40	14.90	NLI
			0.8904	14.40	14.90	27

Turbidity Effluent	66	6.700	0.8243	6.500	6.900	28
			0.8676	6.443	6.900	NLI
			0.8904	6.400	6.900	27
Composite Influent	66	12.40	0.8243	12.40	12.40	28
			0.8676	12.40	12.40	NLI
			0.8904	12.40	12.40	27
Composite Effluent	66	7.100	0.8243	7.100	7.100	28
			0.8676	7.100	7.100	NLI
			0.8904	7.100	7.100	27

Kruskal-Wallis: Conclusions

The following groups showed significant differences (adjusted for ties):

Groups	Z vs. Critical value
Turbidity Effluent vs. Composite Influent	7.27695 >= 2.128
Turbidity Influent vs. Turbidity Effluent	7.09735 >= 2.128
Composite Influent vs. Composite Effluent	6.61531 >= 2.128
Turbidity Influent vs. Composite Effluent	6.43570 >= 2.128

P-value

0
0
0
0

Appendix F.5: Kruskal-Wallis Multiple Comparison for the December 11, 2010 Turbidity

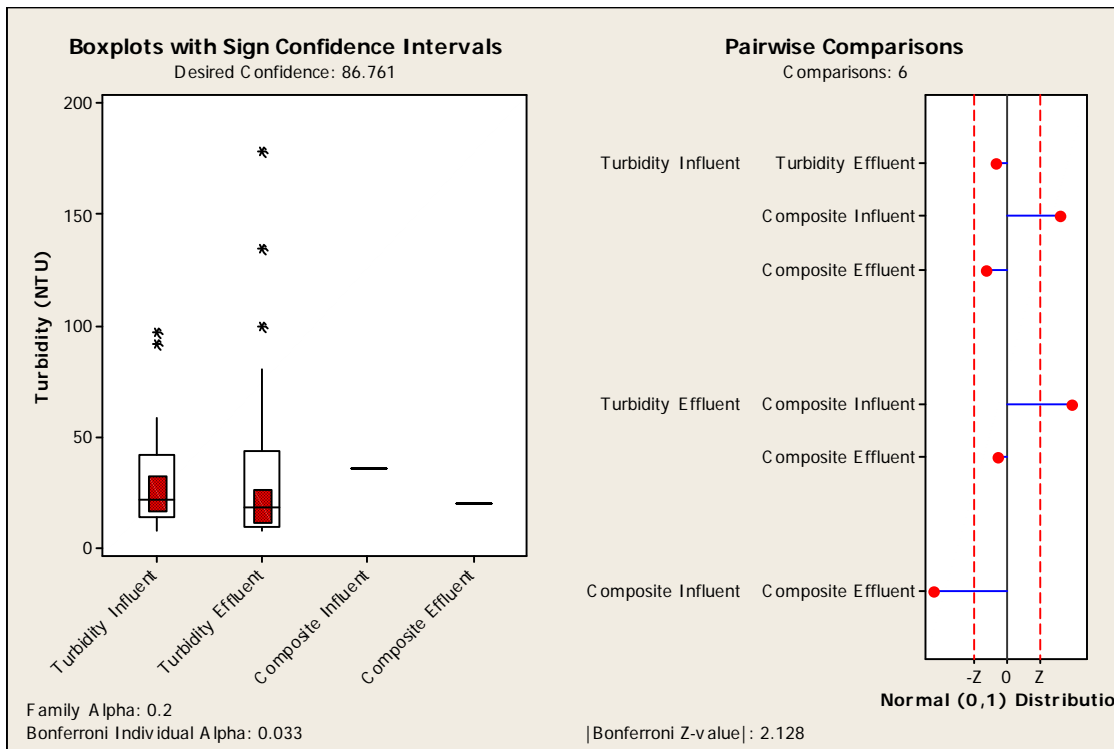
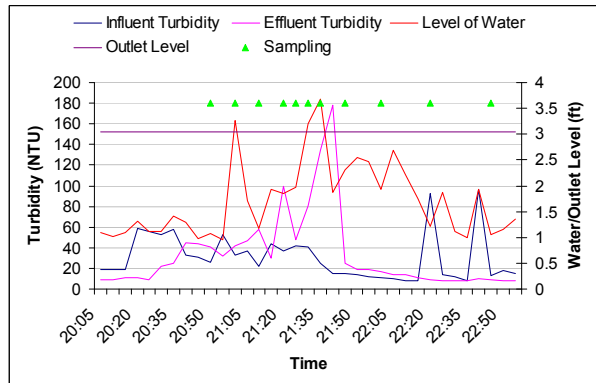
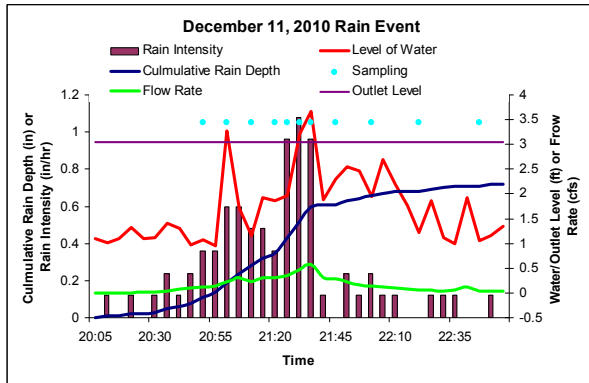

Kruskal-Wallis: Multiple Comparisons

Kruskal-Wallis Test on the data

Group	N	Median	Ave Rank	Z
Turbidity Influent	35	21.70	67.8	-0.45
Turbidity Effluent	35	18.70	60.2	-1.74
Composite Influent	35	35.50	100.0	4.97

Composite Effluent 35 20.10 54.0 -2.78
 Overall 140 70.5

H = 26.73 DF = 3 P = 0.000
 H = 27.60 DF = 3 P = 0.000 (adjusted for ties)

Kruskal-Wallis: All Pairwise Comparisons

 Comparisons: 6
 Ties: 73
 Family Alpha: 0.2
 Bonferroni Individual Alpha: 0.033
 Bonferroni Z-value (2-sided): 2.128

Standardized Absolute Mean Rank Differences
 $|Rbar(i)-Rbar(j)| / Stdev$

Rows: Group i = 1,...,n
 Columns: Group j = 1,...,n

1. Table of Z-values

Turbidity Influent	0.00000		*	*	*
Turbidity Effluent	0.79272	0.00000		*	*
Composite Influent	3.31676	4.10948	0.00000		*
Composite Effluent	1.42778	0.63506	4.74454	0	

 Adjusted for Ties in the Data

1. Table of Z-values

Turbidity Influent	0.00000		*	*	*
Turbidity Effluent	0.80540	0.00000		*	*
Composite Influent	3.36980	4.17520	0.00000		*
Composite Effluent	1.45062	0.64522	4.82042	0	

2. Table of P-values

Turbidity Influent	1.00000		*	*	*
Turbidity Effluent	0.42059	1.00000		*	*
Composite Influent	0.00075	0.00003	1.00000		*
Composite Effluent	0.14689	0.51879	0.00000	1	

 Sign Confidence Intervals controlled at a family error rate of 0.2

Desired Confidence: 86.761

Sign confidence interval for median

N	Median	Achieved Confidence	Confidence Interval		Position
			Lower	Upper	

Turbidity Influent	35	21.70	0.8245	17.70	32.70	14
			0.8676	16.73	32.74	NLI
			0.9105	15.10	32.80	13
Turbidity Effluent	35	18.70	0.8245	11.40	25.00	14
			0.8676	11.21	26.64	NLI
			0.9105	10.90	29.40	13
Composite Influent	35	35.50	0.8245	35.50	35.50	14
			0.8676	35.50	35.50	NLI
			0.9105	35.50	35.50	13
Composite Effluent	35	20.10	0.8245	20.10	20.10	14
			0.8676	20.10	20.10	NLI
			0.9105	20.10	20.10	13

Kruskal-Wallis: Conclusions

The following groups showed significant differences (adjusted for ties):

Groups	Z vs. Critical value
Composite Influent vs. Composite Effluent	4.82042 >= 2.128
Turbidity Effluent vs. Composite Influent	4.17520 >= 2.128
Turbidity Influent vs. Composite Influent	3.36980 >= 2.128

P-value

0.0000

0.0000

0.0008

Appendix F.6: Kruskal-Wallis Multiple Comparison for the December 25, 2010 Turbidity

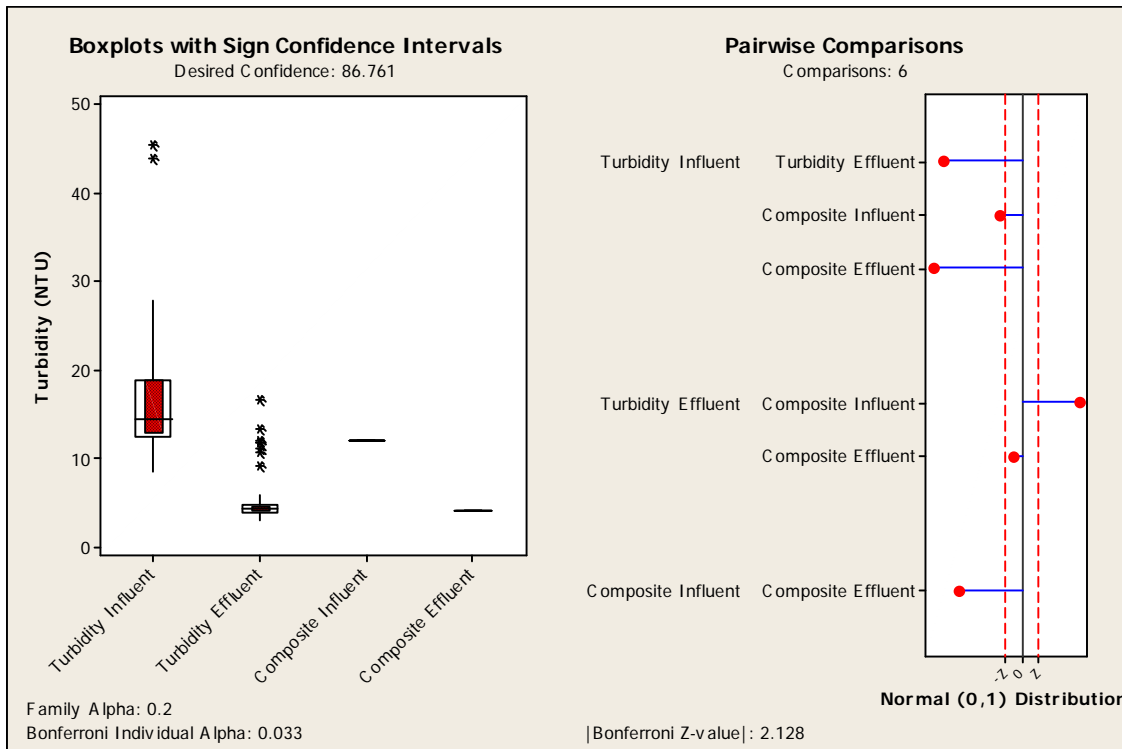
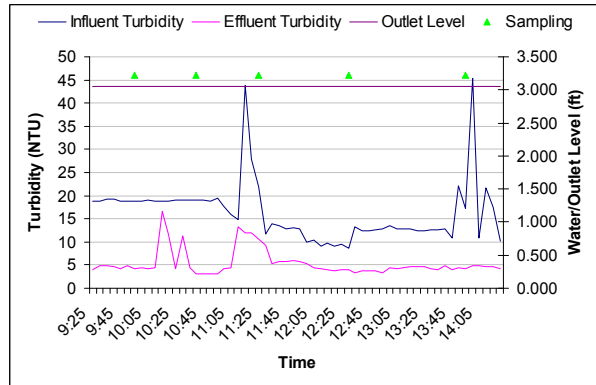
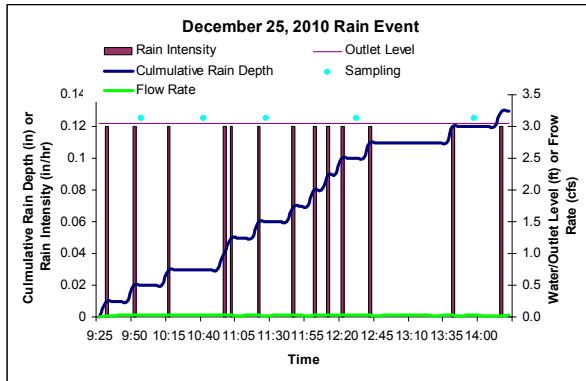

Kruskal-Wallis: Multiple Comparisons

Kruskal-Wallis Test on the data

Group	N	Median	Ave Rank	Z
Turbidity Influent	60	14.400	197.6	9.94
Turbidity Effluent	60	4.400	69.9	-6.52
Composite Influent	60	12.100	159.5	5.02

Composite Effluent 60 4.300 55.0 -8.44
 Overall 240 120.5

H = 178.26 DF = 3 P = 0.000
 H = 184.50 DF = 3 P = 0.000 (adjusted for ties)

Kruskal-Wallis: All Pairwise Comparisons

 Comparisons: 6
 Ties: 172
 Family Alpha: 0.2
 Bonferroni Individual Alpha: 0.033
 Bonferroni Z-value (2-sided): 2.128

Standardized Absolute Mean Rank Differences
 $|Rbar(i)-Rbar(j)| / Stdev$

Rows: Group i = 1,...,n
 Columns: Group j = 1,...,n

1. Table of Z-values

Turbidity Influent	0.0000		*	*	*
Turbidity Effluent	10.0772	0.00000		*	*
Composite Influent	3.0071	7.07011	0.00000	*	
Composite Effluent	11.2514	1.17419	8.24429	0	

 Adjusted for Ties in the Data

1. Table of Z-values

Turbidity Influent	0.0000		*	*	*
Turbidity Effluent	10.2520	0.00000		*	*
Composite Influent	3.0593	7.19271	0.00000	*	
Composite Effluent	11.4465	1.19455	8.38726	0	

2. Table of P-values

Turbidity Influent	1.00000		*	*	*
Turbidity Effluent	0.00000	1.00000		*	*
Composite Influent	0.00222	0.00000	1	*	
Composite Effluent	0.00000	0.23226	0	1	

 Sign Confidence Intervals controlled at a family error rate of 0.2

Desired Confidence: 86.761

Sign confidence interval for median

N	Median	Achieved Confidence	Confidence Interval		Position
			Lower	Upper	

Turbidity Influent	60	14.40	0.8444	12.90	18.80	25
			0.8676	12.90	18.83	NLI
			0.9067	12.90	18.90	24
Turbidity Effluent	60	4.400	0.8444	4.300	4.600	25
			0.8676	4.300	4.600	NLI
			0.9067	4.300	4.600	24
Composite Influent	60	12.10	0.8444	12.10	12.10	25
			0.8676	12.10	12.10	NLI
			0.9067	12.10	12.10	24
Composite Effluent	60	4.300	0.8444	4.300	4.300	25
			0.8676	4.300	4.300	NLI
			0.9067	4.300	4.300	24

Kruskal-Wallis: Conclusions

The following groups showed significant differences (adjusted for ties):

Groups	Z vs. Critical value
Turbidity Influent vs. Composite Effluent	11.4465 >= 2.128
Turbidity Influent vs. Turbidity Effluent	10.2520 >= 2.128
Composite Influent vs. Composite Effluent	8.3873 >= 2.128
Turbidity Effluent vs. Composite Influent	7.1927 >= 2.128
Turbidity Influent vs. Composite Influent	3.0593 >= 2.128

P-value
0.0000
0.0000
0.0000
0.0000
0.0022

Appendix F.7: Kruskal-Wallis Multiple Comparison for the December 31, 2010 Turbidity

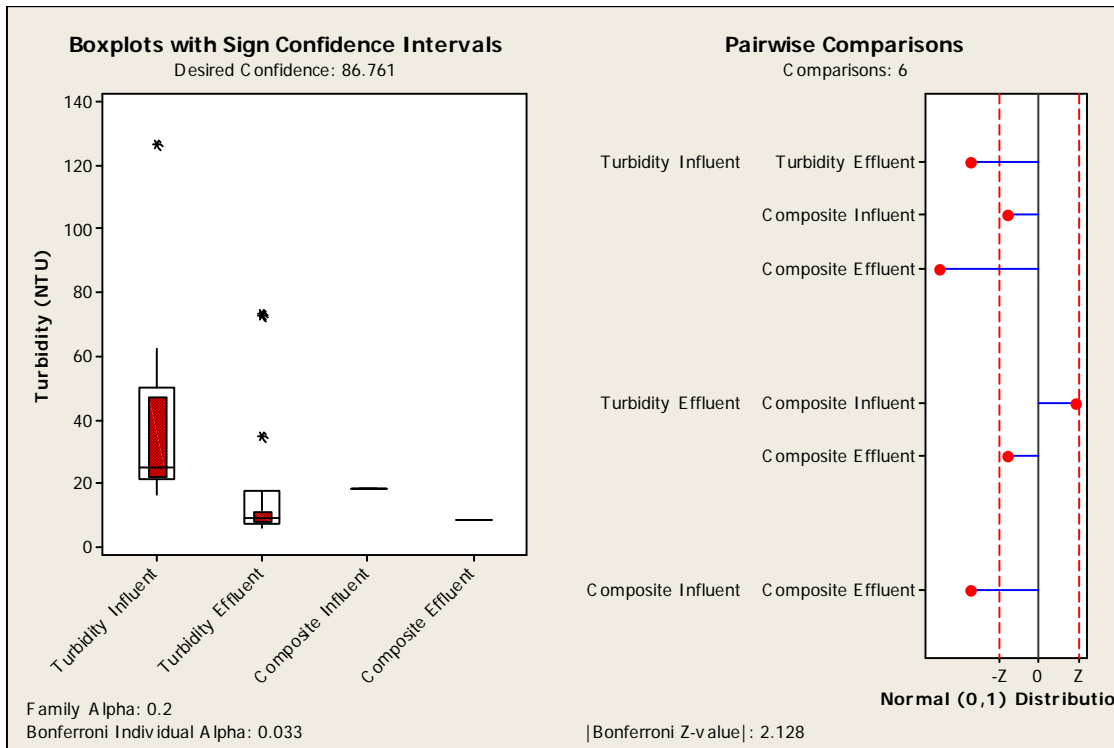
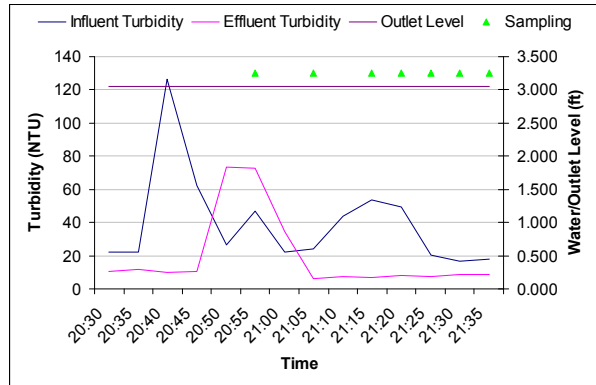
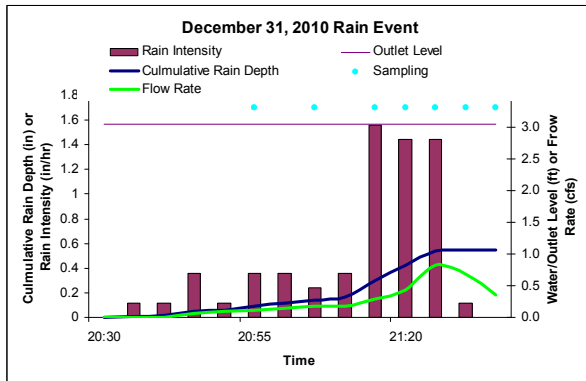

Kruskal-Wallis: Multiple Comparisons

Kruskal-Wallis Test on the data

Group	N	Median	Ave Rank	Z
Turbidity Influent	14	25.200	45.1	4.39
Turbidity Effluent	14	9.250	22.4	-1.61
Composite Influent	14	18.600	34.5	1.59
Composite Effluent	14	8.300	12.0	-4.37
Overall	56		28.5	

H = 32.62 DF = 3 P = 0.000
H = 33.79 DF = 3 P = 0.000 (adjusted for ties)

Kruskal-Wallis: All Pairwise Comparisons

Comparisons: 6
Ties: 29
Family Alpha: 0.2
Bonferroni Individual Alpha: 0.033
Bonferroni Z-value (2-sided): 2.128

Standardized Absolute Mean Rank Differences
 $|\bar{R}(i) - \bar{R}(j)| / \text{Stdev}$

Rows: Group i = 1, ..., n
Columns: Group j = 1, ..., n

1. Table of Z-values

Turbidity Influent	0.00000	*	*	*
Turbidity Effluent	3.67316	0.00000	*	*
Composite Influent	1.71491	1.95824	0.00000	*
Composite Effluent	5.36489	1.69174	3.64998	0

Adjusted for Ties in the Data

1. Table of Z-values

Turbidity Influent	0.00000	*	*	*
Turbidity Effluent	3.73870	0.00000	*	*
Composite Influent	1.74552	1.99319	0.00000	*
Composite Effluent	5.46063	1.72193	3.71512	0

2. Table of P-values

Turbidity Influent	1.00000	*	*	*
Turbidity Effluent	0.00018	1.00000	*	*
Composite Influent	0.08090	0.04624	1.00000	*
Composite Effluent	0.00000	0.08508	0.00020	1

Sign Confidence Intervals controlled at a family error rate of 0.2

Desired Confidence: 86.761

Sign confidence interval for median

	N	Median	Achieved Confidence	Confidence Interval		Position
				Lower	Upper	
Turbidity Influent	14	25.20	0.8204	22.20	46.80	5
			0.8676	22.20	47.30	NLI
			0.9426	22.20	49.30	4

Turbidity Effluent	14	9.25	0.8204	8.30	10.70	5
			0.8676	8.14	10.90	NLI
			0.9426	7.50	11.70	4
Composite Influent	14	18.60	0.8204	18.60	18.60	5
			0.8676	18.60	18.60	NLI
			0.9426	18.60	18.60	4
Composite Effluent	14	8.300	0.8204	8.300	8.300	5
			0.8676	8.300	8.300	NLI
			0.9426	8.300	8.300	4

Kruskal-Wallis: Conclusions

The following groups showed significant differences (adjusted for ties):

Groups	Z vs. Critical value
Turbidity Influent vs. Composite Effluent	5.46063 >= 2.128
Turbidity Influent vs. Turbidity Effluent	3.73870 >= 2.128
Composite Influent vs. Composite Effluent	3.71512 >= 2.128

P-value
0.0000
0.0002
0.0002

Appendix F.8: Kruskal-Wallis Multiple Comparison for the January 1, 2011 Turbidity

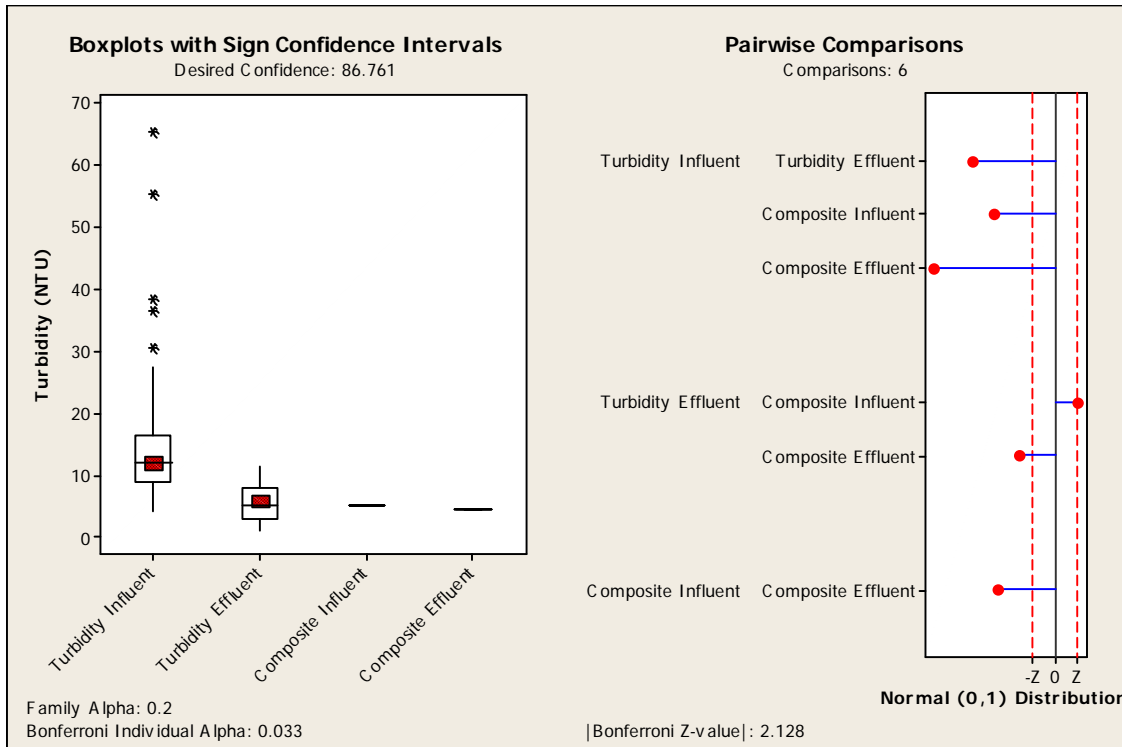
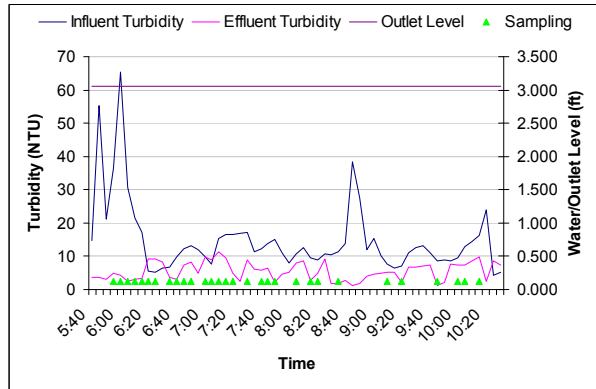
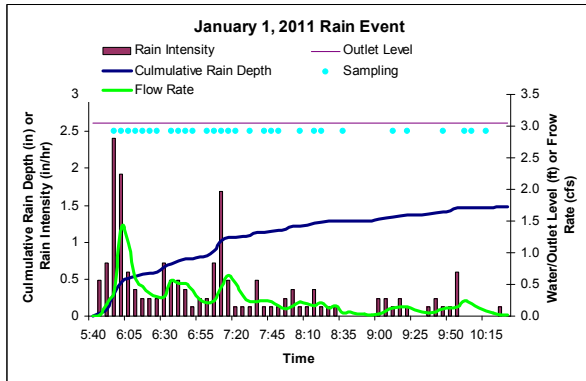

Kruskal-Wallis: Multiple Comparisons

Kruskal-Wallis Test on the data

Group	N	Median	Ave Rank	Z
Turbidity Influent	59	12.000	197.7	10.29
Turbidity Effluent	59	5.100	98.3	-2.63
Composite Influent	59	5.300	123.5	0.65

Composite Effluent 59 4.700 54.5 -8.31
 Overall 236 118.5

H = 136.78 DF = 3 P = 0.000
 H = 141.43 DF = 3 P = 0.000 (adjusted for ties)

Kruskal-Wallis: All Pairwise Comparisons

 Comparisons: 6
 Ties: 149
 Family Alpha: 0.2
 Bonferroni Individual Alpha: 0.033
 Bonferroni Z-value (2-sided): 2.128

Standardized Absolute Mean Rank Differences
 $|Rbar(i)-Rbar(j)| / Stdev$

Rows: Group i = 1,...,n
 Columns: Group j = 1,...,n

1. Table of Z-values

Turbidity Influent	0.0000		*	*	*
Turbidity Effluent	7.9111	0.00000		*	*
Composite Influent	5.9047	2.00642	0.00000	*	
Composite Effluent	11.3940	3.48292	5.48935	0	

 Adjusted for Ties in the Data

1. Table of Z-values

Turbidity Influent	0.0000		*	*	*
Turbidity Effluent	8.0444	0.00000		*	*
Composite Influent	6.0042	2.04024	0.00000	*	
Composite Effluent	11.5860	3.54163	5.58187	0	

2. Table of P-values

Turbidity Influent	1.00000		*	*	*
Turbidity Effluent	0.00000	1.00000		*	*
Composite Influent	0.00000	0.04133	1.00000	*	
Composite Effluent	0.00000	0.00040	0.00000	1	

 Sign Confidence Intervals controlled at a family error rate of 0.2

Desired Confidence: 86.761

Sign confidence interval for median

N	Median	Achieved Confidence	Confidence Interval		Position
			Lower	Upper	

Turbidity Influent	59	12.00	0.8070	11.00	13.00	25
			0.8676	10.93	13.07	NLI
			0.8818	10.90	13.10	24
Turbidity Effluent	59	5.100	0.8070	4.800	6.600	25
			0.8676	4.725	6.675	NLI
			0.8818	4.700	6.700	24
Composite Influent	59	5.300	0.8070	5.300	5.300	25
			0.8676	5.300	5.300	NLI
			0.8818	5.300	5.300	24
Composite Effluent	59	4.700	0.8070	4.700	4.700	25
			0.8676	4.700	4.700	NLI
			0.8818	4.700	4.700	24

Kruskal-Wallis: Conclusions

The following groups showed significant differences (adjusted for ties):

Groups	Z vs. Critical value
Turbidity Influent vs. Composite Effluent	11.5860 >= 2.128
Turbidity Influent vs. Turbidity Effluent	8.0444 >= 2.128
Turbidity Influent vs. Composite Influent	6.0042 >= 2.128
Composite Influent vs. Composite Effluent	5.5819 >= 2.128
Turbidity Effluent vs. Composite Effluent	3.5416 >= 2.128

P-value
0.0000
0.0000
0.0000
0.0000
0.0004

Appendix F.9: Kruskal-Wallis Multiple Comparison for the January 10, 2011 Turbidity

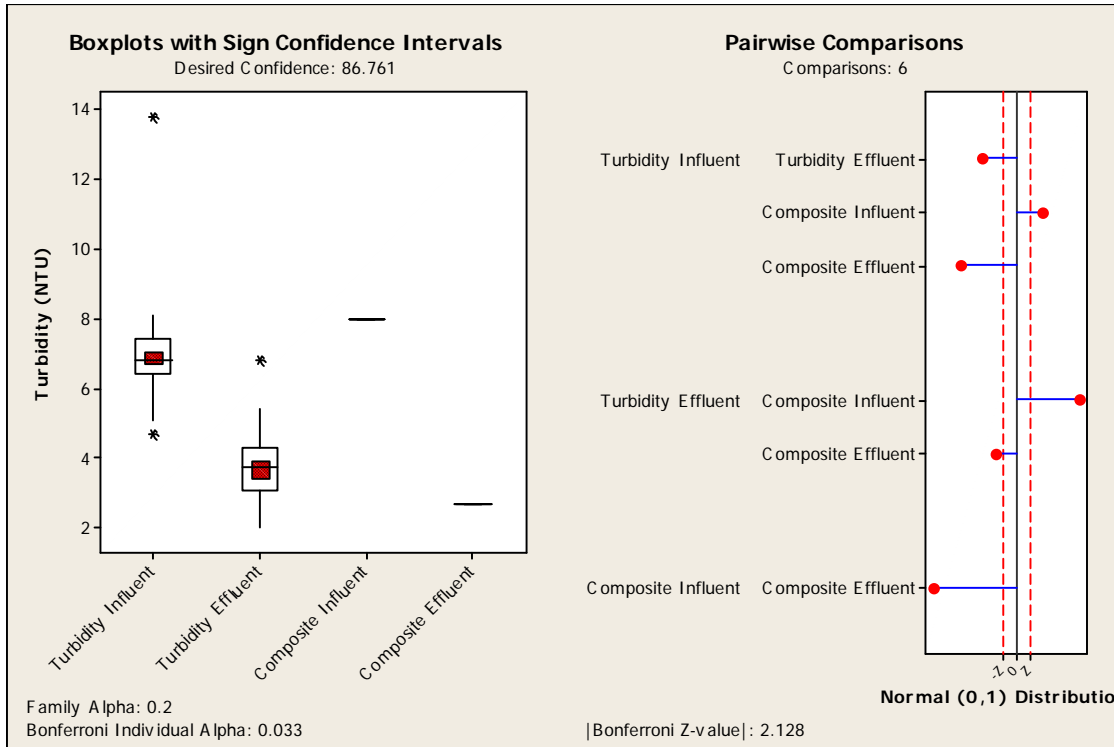
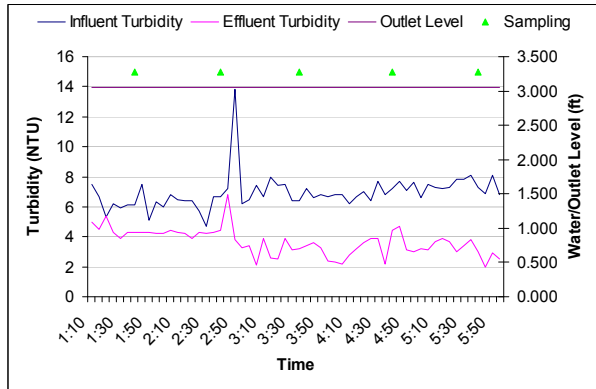
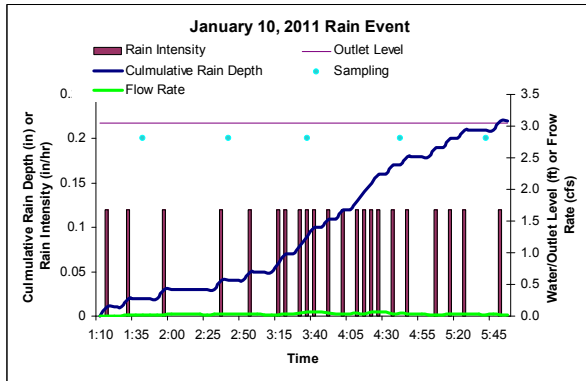

Kruskal-Wallis: Multiple Comparisons

Kruskal-Wallis Test on the data

Group	N	Median	Ave Rank	Z
Turbidity Influent	58	6.800	148.4	4.18
Turbidity Effluent	58	3.750	79.1	-4.90
Composite Influent	58	8.000	200.0	10.94
Composite Effluent	58	2.700	38.5	-10.22
Overall	232		116.5	

H = 199.23 DF = 3 P = 0.000
H = 205.86 DF = 3 P = 0.000 (adjusted for ties)

Kruskal-Wallis: All Pairwise Comparisons

Comparisons: 6
Ties: 178
Family Alpha: 0.2
Bonferroni Individual Alpha: 0.033
Bonferroni Z-value (2-sided): 2.128

Standardized Absolute Mean Rank Differences
|Rbar(i)-Rbar(j)| / Stdev

Rows: Group i = 1,...,n
Columns: Group j = 1,...,n

1. Table of Z-values

Turbidity Influent	0.00000		*	*	*
Turbidity Effluent	5.56116	0.00000		*	*
Composite Influent	4.13975	9.70091	0.0000	*	
Composite Effluent	8.81832	3.25715	12.9581	0	

Adjusted for Ties in the Data

1. Table of Z-values

Turbidity Influent	0.00000		*	*	*
Turbidity Effluent	5.65294	0.00000		*	*
Composite Influent	4.20807	9.86101	0.0000	*	
Composite Effluent	8.96385	3.31091	13.1719	0	

2. Table of P-values

Turbidity Influent	1.00000		*	*	*
Turbidity Effluent	0.00000	1.00000		*	*
Composite Influent	0.00003	0.00000	1	*	
Composite Effluent	0.00000	0.00093	0	1	

Sign Confidence Intervals controlled at a family error rate of 0.2

Desired Confidence: 86.761

Sign confidence interval for median

	N	Median	Achieved Confidence	Confidence Interval		Position
				Lower	Upper	
Turbidity Influent	58	6.800	0.8514	6.700	7.000	24
			0.8676	6.700	7.019	NLI
			0.9122	6.700	7.100	23

Turbidity Effluent	58	3.750	0.8514	3.400	3.900	24
			0.8676	3.400	3.900	NLI
			0.9122	3.400	3.900	23
Composite Influent	58	8.000	0.8514	8.000	8.000	24
			0.8676	8.000	8.000	NLI
			0.9122	8.000	8.000	23
Composite Effluent	58	2.700	0.8514	2.700	2.700	24
			0.8676	2.700	2.700	NLI
			0.9122	2.700	2.700	23

Kruskal-Wallis: Conclusions

The following groups showed significant differences (adjusted for ties):

Groups	Z vs. Critical value
Composite Influent vs. Composite Effluent	13.1719 >= 2.128
Turbidity Effluent vs. Composite Influent	9.8610 >= 2.128
Turbidity Influent vs. Composite Effluent	8.9639 >= 2.128
Turbidity Influent vs. Turbidity Effluent	5.6529 >= 2.128
Turbidity Influent vs. Composite Influent	4.2081 >= 2.128
Turbidity Effluent vs. Composite Effluent	3.3109 >= 2.128

P-value
0.0000
0.0000
0.0000
0.0000
0.0000
0.0009

Appendix F.10: Kruskal-Wallis Multiple Comparison for the January 25, 2011 Turbidity

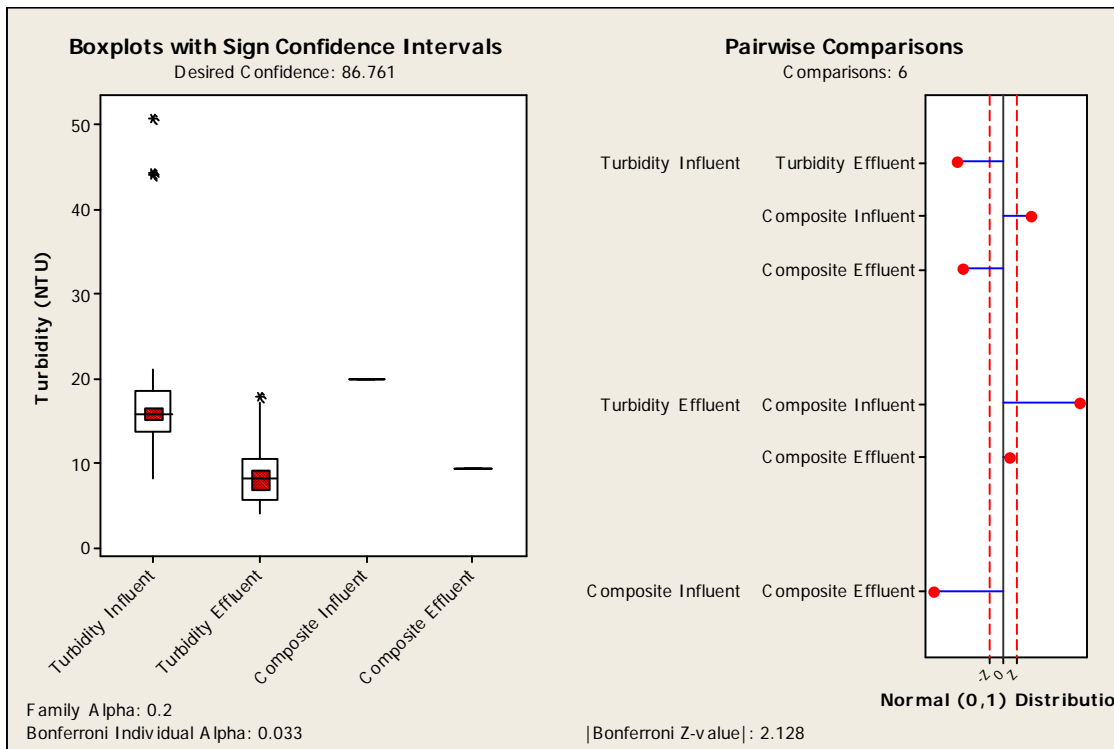
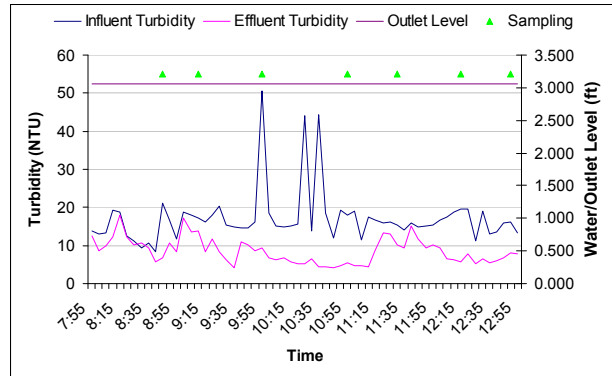
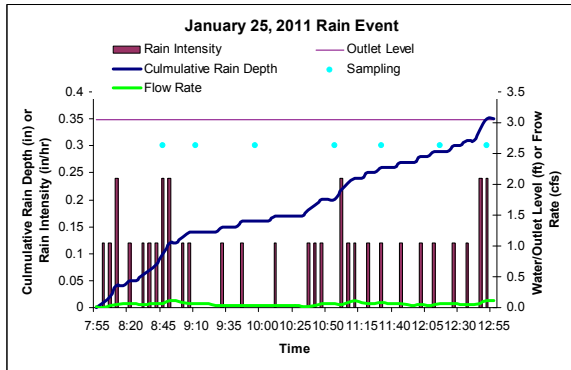

Kruskal-Wallis: Multiple Comparisons

Kruskal-Wallis Test on the data

Group	N	Median	Ave Rank	Z
Turbidity Influent	61	15.900	152.3	3.81
Turbidity Effluent	61	8.300	58.2	-8.22
Composite Influent	61	20.000	209.0	11.05
Composite Effluent	61	9.400	70.5	-6.64

Overall 244 122.5
 H = 186.26 DF = 3 P = 0.000
 H = 192.42 DF = 3 P = 0.000 (adjusted for ties)

Kruskal-Wallis: All Pairwise Comparisons

 Comparisons: 6
 Ties: 155
 Family Alpha: 0.2
 Bonferroni Individual Alpha: 0.033
 Bonferroni Z-value (2-sided): 2.128

Standardized Absolute Mean Rank Differences
 |Rbar(i)-Rbar(j)| / Stdev

Rows: Group i = 1,...,n
 Columns: Group j = 1,...,n

1. Table of Z-values

Turbidity Influent	0.00000		*	*	*
Turbidity Effluent	7.36475	0.0000		*	*
Composite Influent	4.43565	11.8004	0.0000		*
Composite Effluent	6.40143	0.9633	10.8371	0	

Adjusted for Ties in the Data

1. Table of Z-values

Turbidity Influent	0.00000		*	*	*
Turbidity Effluent	7.48567	0.0000		*	*
Composite Influent	4.50848	11.9942	0.0000		*
Composite Effluent	6.50653	0.9791	11.0150	0	

2. Table of P-values

Turbidity Influent	1.00000		*	*	*
Turbidity Effluent	0.00000	1.00000		*	*
Composite Influent	0.00001	0.00000	1		*
Composite Effluent	0.00000	0.32751	0	1	

 Sign Confidence Intervals controlled at a family error rate of 0.2

Desired Confidence: 86.761

Sign confidence interval for median

	N	Median	Achieved Confidence	Confidence Interval		Position
				Lower	Upper	
Turbidity Influent	61	15.90	0.7996	15.30	16.20	26

				0.8676	15.13	16.54	NLI
				0.8756	15.10	16.60	25
Turbidity Effluent	61	8.300		0.7996	6.800	8.900	26
				0.8676	6.800	9.242	NLI
				0.8756	6.800	9.300	25
Composite Influent	61	20.00		0.7996	20.00	20.00	26
				0.8676	20.00	20.00	NLI
				0.8756	20.00	20.00	25
Composite Effluent	61	9.400		0.7996	9.400	9.400	26
				0.8676	9.400	9.400	NLI
				0.8756	9.400	9.400	25

Kruskal-Wallis: Conclusions

The following groups showed significant differences (adjusted for ties):

Groups	Z vs. Critical value
Turbidity Effluent vs. Composite Influent	11.9942 >= 2.128
Composite Influent vs. Composite Effluent	11.0150 >= 2.128
Turbidity Influent vs. Turbidity Effluent	7.4857 >= 2.128
Turbidity Influent vs. Composite Effluent	6.5065 >= 2.128
Turbidity Influent vs. Composite Influent	4.5085 >= 2.128

P-value

0
0
0
0
0

Appendix F.11: Kruskal-Wallis Multiple Comparison for the April 11, 2011 Turbidity

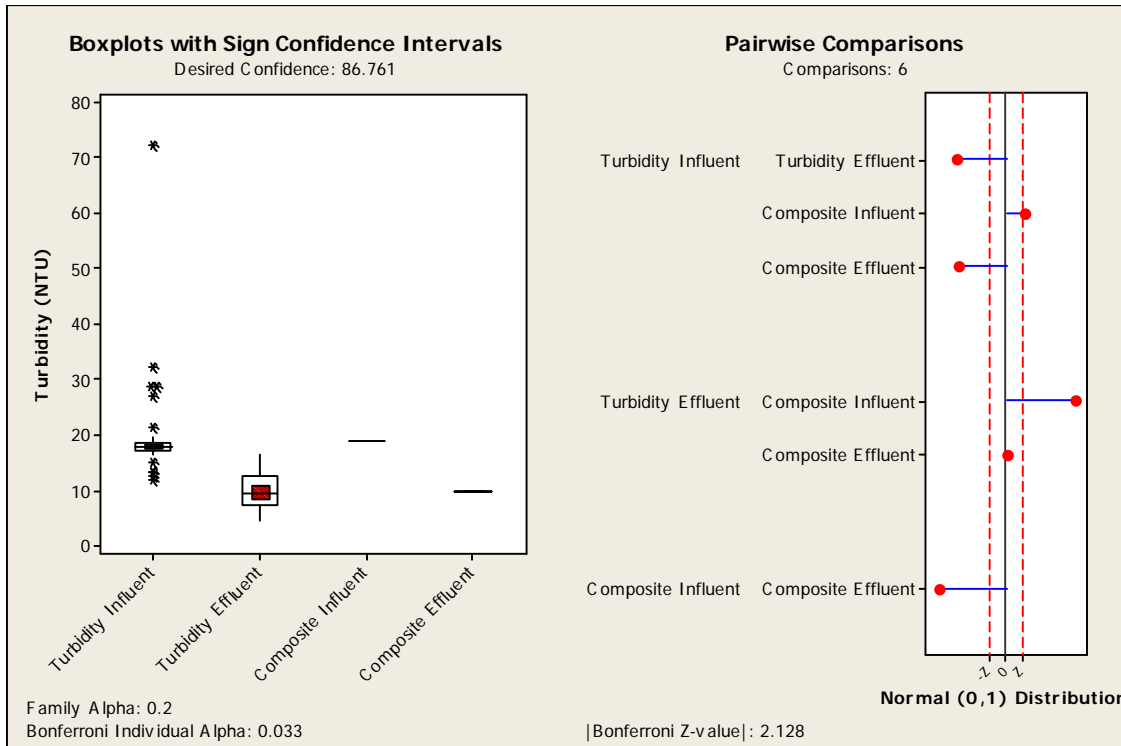
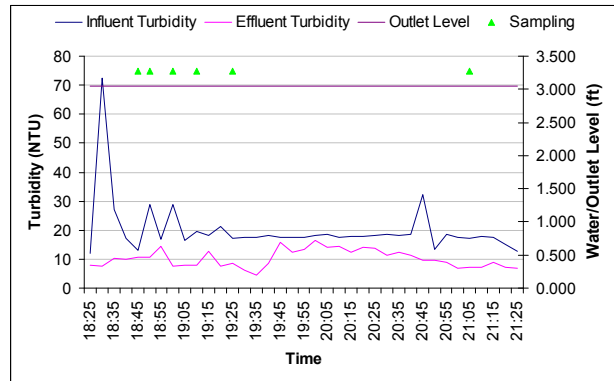
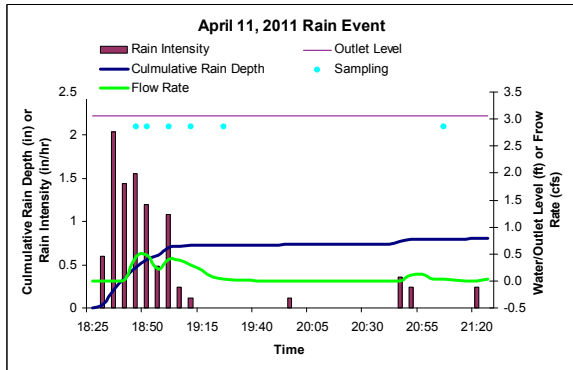

Kruskal-Wallis: Multiple Comparisons

Kruskal-Wallis Test on the data

Group	N	Median	Ave Rank	Z
Turbidity Influent	37	17.800	99.0	4.01
Turbidity Effluent	37	9.500	37.0	-6.14
Composite Influent	37	18.900	123.0	7.95
Composite Effluent	37	10.000	39.0	-5.82
Overall	148		74.5	

H = 113.10 DF = 3 P = 0.000
H = 116.76 DF = 3 P = 0.000 (adjusted for ties)

Kruskal-Wallis: All Pairwise Comparisons

Comparisons: 6
Ties: 94
Family Alpha: 0.2
Bonferroni Individual Alpha: 0.033
Bonferroni Z-value (2-sided): 2.128

Standardized Absolute Mean Rank Differences
|Rbar(i)-Rbar(j)| / Stdev

Rows: Group i = 1,...,n
Columns: Group j = 1,...,n

1. Table of Z-values

Turbidity Influent	0.00000		*	*	*
Turbidity Effluent	6.21806	0.00000		*	*
Composite Influent	2.40940	8.62745	0.00000	*	
Composite Effluent	6.01874	0.19931	8.42814	0	

Adjusted for Ties in the Data

1. Table of Z-values

Turbidity Influent	0.00000		*	*	*
Turbidity Effluent	6.31775	0.00000		*	*
Composite Influent	2.44802	8.76577	0.00000	*	
Composite Effluent	6.11524	0.20251	8.56326	0	

2. Table of P-values

Turbidity Influent	1.00000		*	*	*
Turbidity Effluent	0.00000	1.00000	*	*	
Composite Influent	0.01436	0.00000	1	*	
Composite Effluent	0.00000	0.83952	0	1	

Sign Confidence Intervals controlled at a family error rate of 0.2

Desired Confidence: 86.761

Sign confidence interval for median

	N	Median	Confidence Interval			Position
			Achieved Confidence	Lower	Upper	
Turbidity Influent	37	17.80	0.8123	17.50	18.10	15
			0.8676	17.50	18.10	NLI
			0.9011	17.50	18.10	14

Turbidity Effluent	37	9.50	0.8123	8.70	10.50	15
			0.8676	8.60	10.90	NLI
			0.9011	8.50	11.30	14
Composite Influent	37	18.90	0.8123	18.90	18.90	15
			0.8676	18.90	18.90	NLI
			0.9011	18.90	18.90	14
Composite Effluent	37	10.00	0.8123	10.00	10.00	15
			0.8676	10.00	10.00	NLI
			0.9011	10.00	10.00	14

Kruskal-Wallis: Conclusions

The following groups showed significant differences (adjusted for ties):

Groups	Z vs. Critical value
Turbidity Effluent vs. Composite Influent	8.76577 >= 2.128
Composite Influent vs. Composite Effluent	8.56326 >= 2.128
Turbidity Influent vs. Turbidity Effluent	6.31775 >= 2.128
Turbidity Influent vs. Composite Effluent	6.11524 >= 2.128
Turbidity Influent vs. Composite Influent	2.44802 >= 2.128

P-value
0.0000
0.0000
0.0000
0.0000
0.0144

Appendix G.1: Sand Media 25gpm TSS Probability Analysis Detail

SUMMARY OUTPUT

<i>Regression Statistics</i>	
Multiple R	0.902
R Square	0.813
Adjusted R Square	0.800
Standard Error	9.887
Observations	16.000

ANOVA					
	<i>df</i>	<i>SS</i>	<i>MS</i>	<i>F</i>	<i>Significance F</i>
Regression	1.000	5967.308	5967.308	61.045	0.000
Residual	14.000	1368.539	97.753		
Total	15.000	7335.847			

	<i>Coefficients</i>	<i>Standard Error</i>	<i>t Stat</i>	<i>P-value</i>	<i>Lower 95%</i>	<i>Upper 95%</i>	<i>Lower 95.0%</i>	<i>Upper 95.0%</i>
Intercept	35.043	4.181	8.381	0.000	26.075	44.011	26.075	44.011
X Variable 1	0.118	0.015	7.813	0.000	0.086	0.151	0.086	0.151

Mann-Whitney-Wilcoxon Test

n ₁	16
n ₂	16
Observed T	360.000
Expected T	264.000
Std. Dev. T	26.533
Test Statistic	3.618
p-Value (lower tail)	0.9999
p-Value (upper tail)	0.000
p-Value (two tail)	0.000
Reject H ₀ , if p-Value < 0.05	
Significant Diff?	Yes
H ₀ : Influent and Effluent Concentration is Same	
H _a : Influent and Effluent Concentration is Differ	

TSS Influent vs. Effluent Probability in 95% Confidence Interval

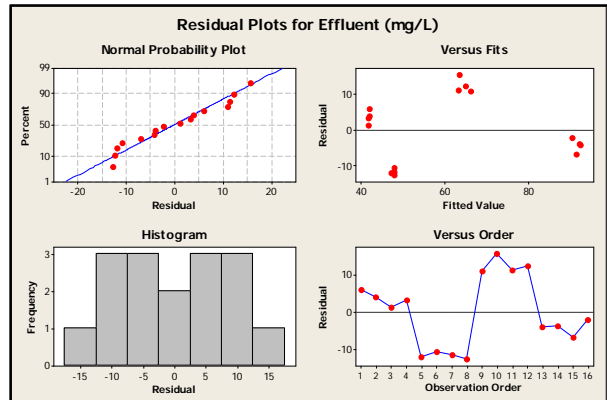
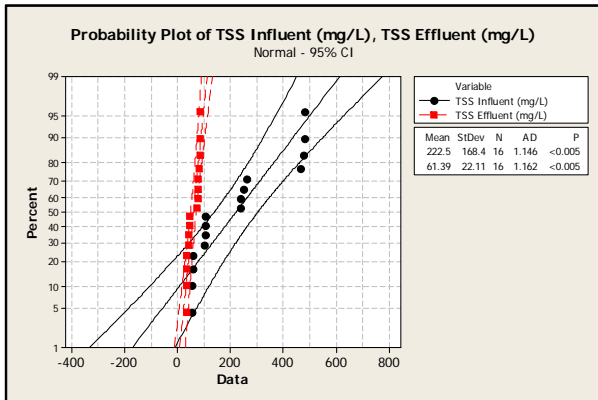
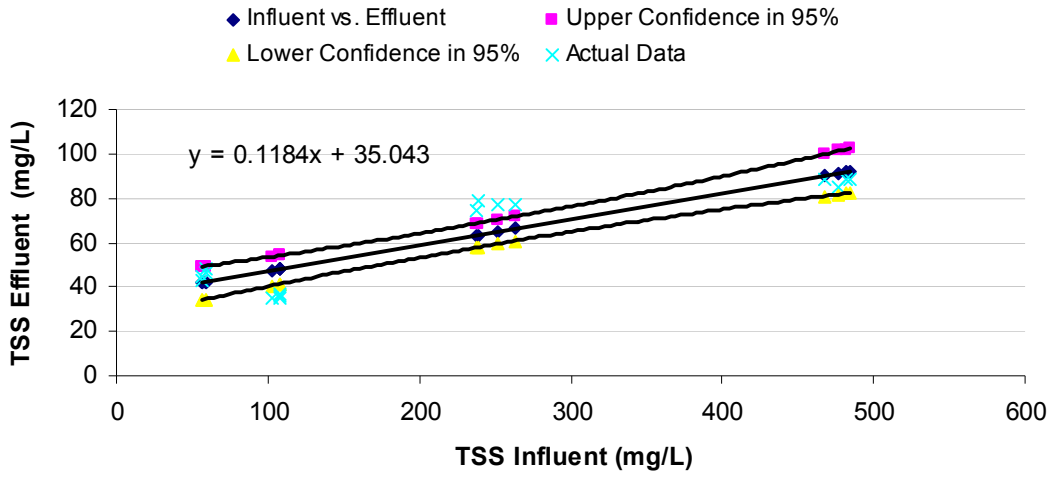

Appendix G.2: Sand Media 25gpm TDS Probability Analysis Detail

SUMMARY OUTPUT

<i>Regression Statistics</i>	
Multiple R	0.868
R Square	0.754
Adjusted R Square	0.736
Standard Error	28.106
Observations	16.000

ANOVA					
	<i>df</i>	<i>SS</i>	<i>MS</i>	<i>F</i>	<i>Significance F</i>
Regression	1.000	33861.956	33861.956	42.867	0.000
Residual	14.000	11058.982	789.927		
Total	15.000	44920.938			

	<i>Coefficients</i>	<i>Standard Error</i>	<i>t Stat</i>	<i>P-value</i>	<i>Lower 95%</i>	<i>Upper 95%</i>	<i>Lower 95.0%</i>	<i>Upper 95.0%</i>
Intercept	-78.031	40.041	-1.949	0.072	-163.910	7.849	-163.910	7.849
X Variable 1	1.031	0.158	6.547	0.000	0.693	1.369	0.693	1.369

Mann-Whitney-Wilcoxon Test

n ₁	16
n ₂	16
Observed T	354.000
Expected T	264.000
Std. Dev. T	26.533
Test Statistic	3.392
p-Value (lower t	0.999653
p-Value (upper	0.000
p-Value (two ta	0.001 Reject H ₀ , if p-Value < 0.05
Significant Diff? Yes	
H ₀ : Influent and Effluent Concentration is Same	
H _a : Influent and Effluent Concentration is Differ	

TDS Influent vs. Effluent Probability in 95% Confidence Interval

- ◆ Influent vs. Effluent ■ Upper Confidence in 95%
- ▲ Lower Confidence in 95% × Actual Data

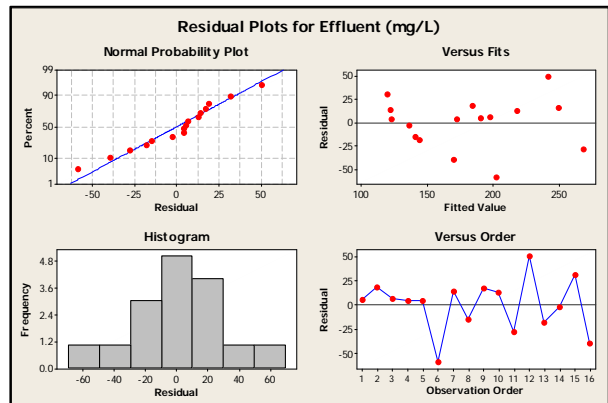
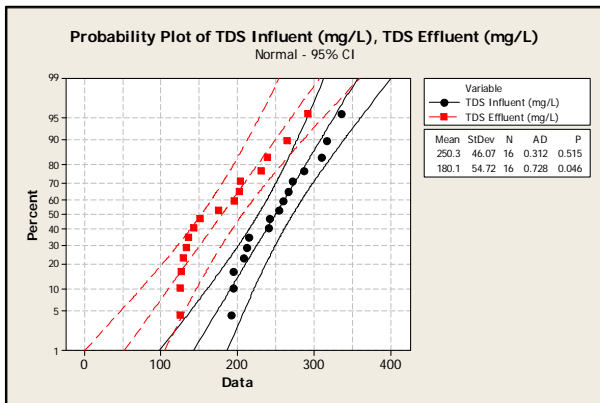
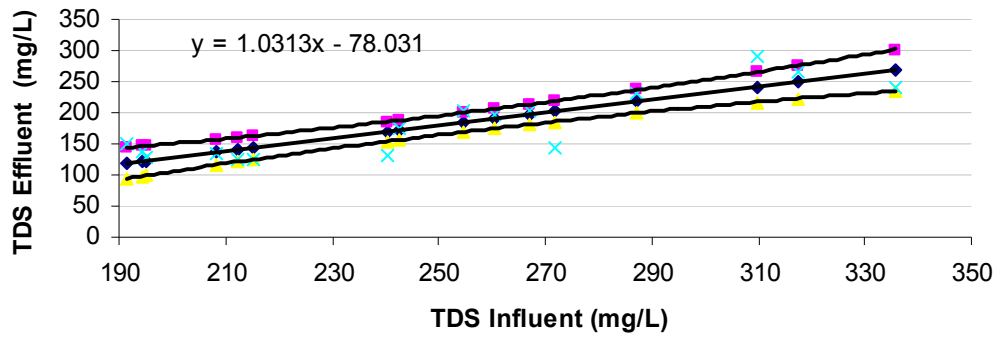

Appendix G.3: Sand Media 25gpm 0.45-3 μm Probability Analysis Detail

SUMMARY OUTPUT

Regression Statistics	
Multiple R	0.875
R Square	0.766
Adjusted R Square	0.749
Standard Error	0.741
Observations	16.000

ANOVA

	df	SS	MS	F	Significance F
Regression	1.000	25.210	25.210	45.856	0.000
Residual	14.000	7.697	0.550		
Total	15.000	32.907			

	Coefficients	Standard Error	t Stat	P-value	Lower 95%	Upper 95%	Lower 95.0%	Upper 95.0%
Intercept	0.729	0.308	2.363	0.033	0.067	1.390	0.067	1.390
X Variable 1	0.114	0.017	6.772	0.000	0.078	0.150	0.078	0.150

Mann-Whitney-Wilcoxon Test

n_1	16
n_2	16
Observed T	376.000
Expected T	264.000
Std. Dev. T	26.533
Test Statistic	4.221
p-Value (lower)	0.999988
p-Value (upper)	0.000
p-Value (two ta	0.000
Reject H_0 , if p-Value < 0.05	
Significant Diff? Yes	
H_0 : Influent and Effluent Concentration is Same	
H_a : Influent and Effluent Concentration is Differ	

0.45~3 μm Solids Influent vs. Effluent Probability in 95% Confidence Interval

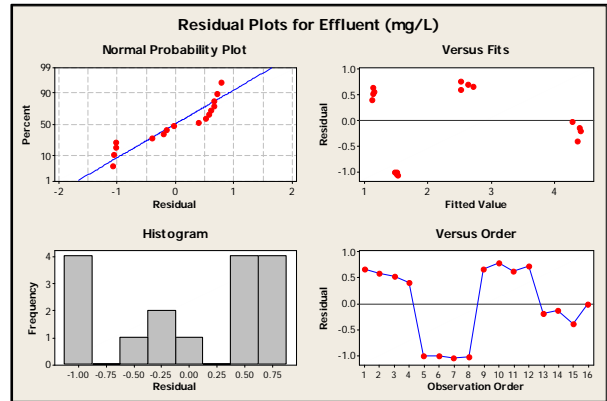
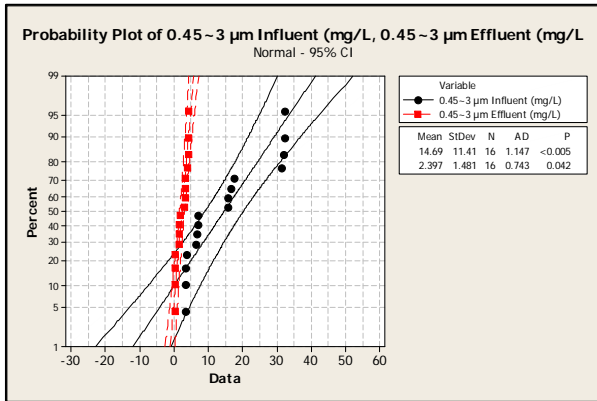
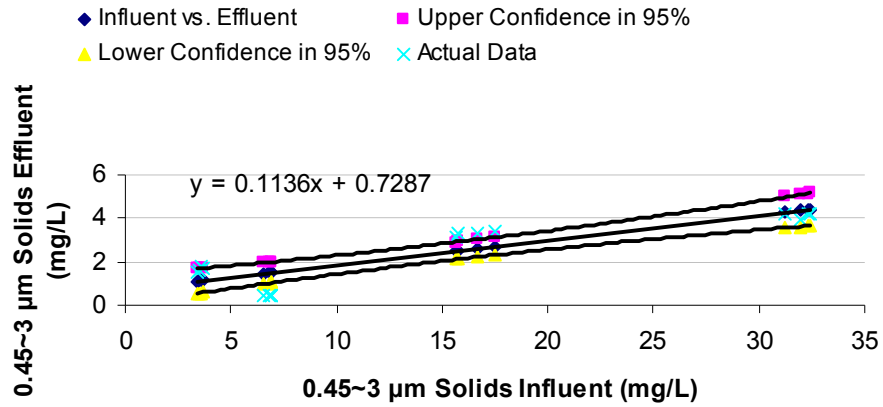

Appendix G.4: Sand Media 25gpm 3-12 μm Probability Analysis Detail

SUMMARY OUTPUT

<i>Regression Statistics</i>	
Multiple R	0.966
R Square	0.932
Adjusted R Square	0.866
Standard Error	8.279
Observations	16.000

ANOVA					
	<i>df</i>	<i>SS</i>	<i>MS</i>	<i>F</i>	<i>Significance F</i>
Regression	1.000	14165.979	14165.979	206.673	0.000
Residual	15.000	1028.143	68.543		
Total	16.000	15194.122			

	<i>Coefficients</i>	<i>Standard Error</i>	<i>t Stat</i>	<i>P-value</i>	<i>Lower 95%</i>	<i>Upper 95%</i>	<i>Lower 95.0%</i>	<i>Upper 95.0%</i>
Intercept	0.000	#N/A	#N/A	#N/A	#N/A	#N/A	#N/A	#N/A
X Variable 1	0.413	0.029	14.376	0.000	0.352	0.474	0.352	0.474

Mann-Whitney-Wilcoxon Test

n_1	16
n_2	16
Observed T	335.000
Expected T	264.000
Std. Dev. T	26.533
Test Statistic	2.676
p-Value (lower t	0.996274
p-Value (upper	0.004
p-Value (two ta	0.007
Reject H_0 , if p-Value < 0.05	
Significant Diff? Yes	
H_0 : Influent and Effluent Concentration is Same	
H_a : Influent and Effluent Concentration is Differ	

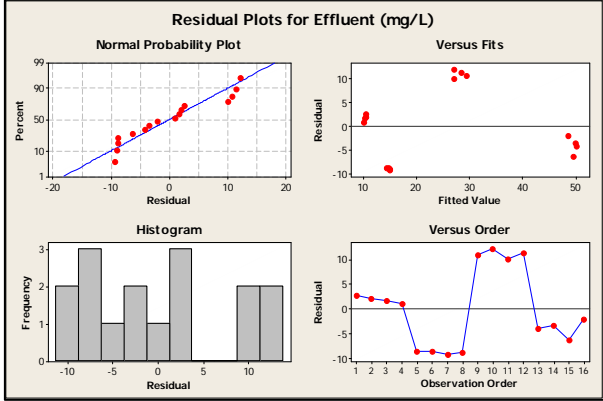
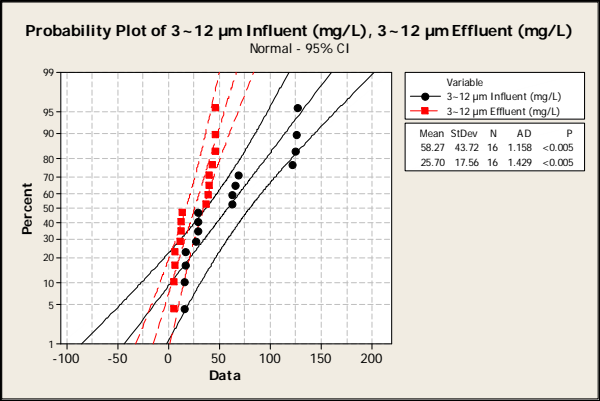
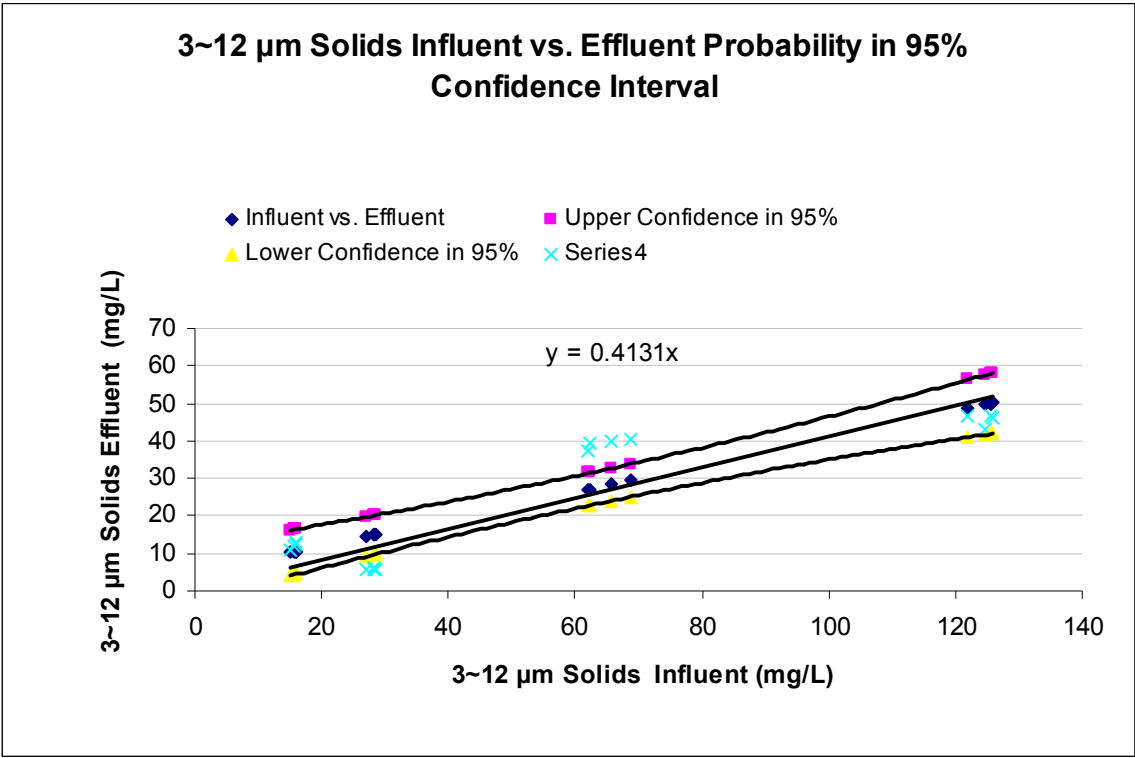

Appendix G.5: Sand Media 25gpm 12-30 μ m Probability Analysis Detail

SUMMARY OUTPUT

<i>Regression Statistics</i>	
Multiple R	0.939
R Square	0.882
Adjusted R Square	0.874
Standard Error	3.589
Observations	16.000

ANOVA

	<i>df</i>	<i>SS</i>	<i>MS</i>	<i>F</i>	<i>Significance F</i>
Regression	1.000	1351.589	1351.589	104.947	0.000
Residual	14.000	180.303	12.879		
Total	15.000	1531.892			

	<i>Coefficients</i>	<i>Standard Error</i>	<i>t Stat</i>	<i>P-value</i>	<i>Lower 95%</i>	<i>Upper 95%</i>	<i>Lower 95.0%</i>	<i>Upper 95.0%</i>
Intercept	5.567	1.516	3.673	0.003	2.317	8.818	2.317	8.818
X Variable 1	0.173	0.017	10.244	0.000	0.137	0.209	0.137	0.209

Mann-Whitney-Wilcoxon Test

n_1	16
n_2	16
Observed T	362.000
Expected T	264.000
Std. Dev. T	26.533
Test Statistic	3.694
p-Value (lower t	0.999889
p-Value (upper	0.000
p-Value (two ta	0.000
Reject H_0 , if p-Value < 0.05	
Significant Diff? Yes	
H_0 : Influent and Effluent Concentration is Same	
H_a : Influent and Effluent Concentration is Differ	

12~30 µm Solids Influent vs. Effluent Probability in 95% Confidence Interval

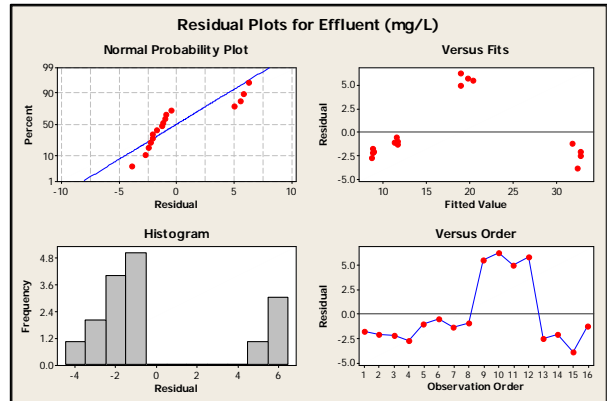
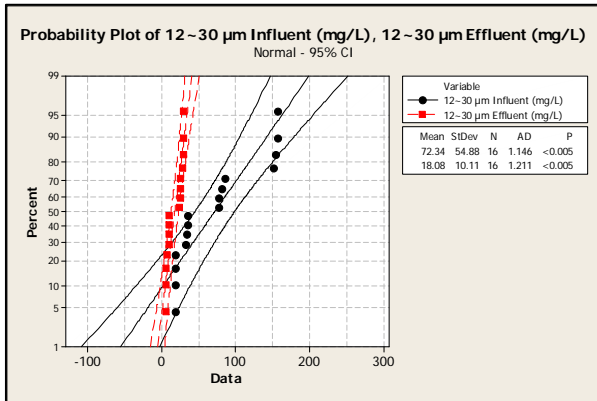
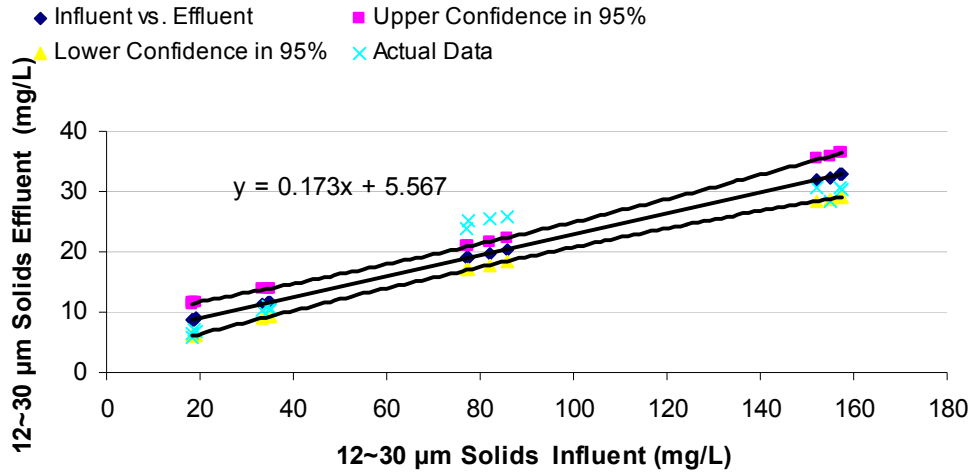

Appendix G.6: Sand Media 25gpm 30-60 μ m Probability Analysis Detail

SUMMARY OUTPUT

<i>Regression Statistics</i>	
Multiple R	0.153
R Square	0.023
Adjusted R Square	-0.046
Standard Error	1.406
Observations	16.000

ANOVA					
	<i>df</i>	<i>SS</i>	<i>MS</i>	<i>F</i>	<i>Significance F</i>
Regression	1.000	0.664	0.664	0.336	0.571
Residual	14.000	27.673	1.977		
Total	15.000	28.337			

	<i>Coefficients</i>	<i>Standard Error</i>	<i>t Stat</i>	<i>P-value</i>	<i>Lower 95%</i>	<i>Upper 95%</i>	<i>Lower 95.0%</i>	<i>Upper 95.0%</i>
Intercept	4.046	0.592	6.830	0.000	2.775	5.316	2.775	5.316
X Variable 1	0.007	0.013	0.580	0.571	-0.020	0.034	-0.020	0.034

Mann-Whitney-Wilcoxon Test

n_1	16
n_2	16
Observed T	392.000
Expected T	264.000
Std. Dev. T	26.533
Test Statistic	4.824
p-Value (lower)	0.999999
p-Value (upper)	0.000
p-Value (two ta	0.000
Reject H_0 , if p-Value < 0.05	
Significant Diff? Yes	
H_0 : Influent and Effluent Concentration is Same	
H_a : Influent and Effluent Concentration is Differ	

30~60 μm Solids Influent vs. Effluent Probability in 95% Confidence Interval

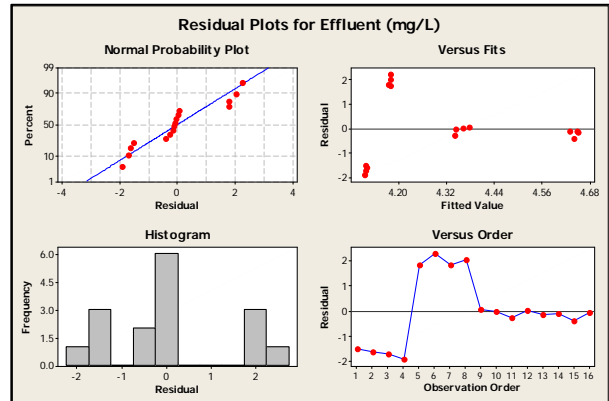
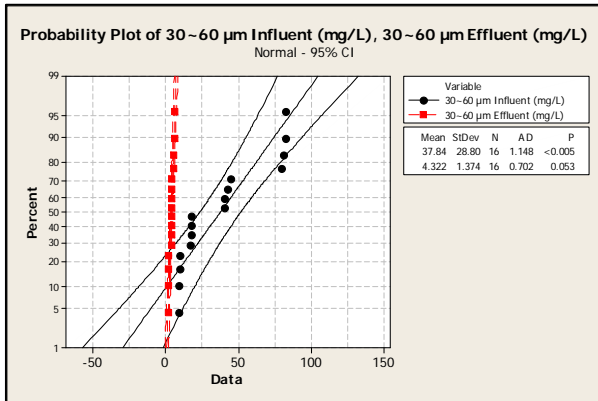
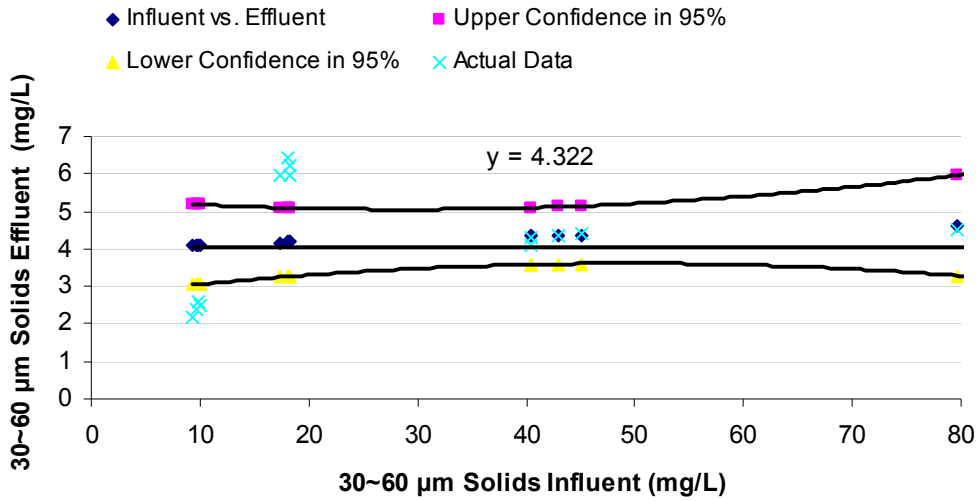

Appendix G.7: Sand Media 25gpm 60-120 µm Probability Analysis Detail

SUMMARY OUTPUT

<i>Regression Statistics</i>	
Multiple R	0.542
R Square	0.293
Adjusted R Square	0.243
Standard Error	0.711
Observations	16.000

ANOVA

	<i>df</i>	<i>SS</i>	<i>MS</i>	<i>F</i>	<i>Significance F</i>
Regression	1.000	2.936	2.936	5.809	0.030
Residual	14.000	7.077	0.505		
Total	15.000	10.013			

	<i>Coefficients</i>	<i>Standard Error</i>	<i>t Stat</i>	<i>P-value</i>	<i>Lower 95%</i>	<i>Upper 95%</i>	<i>Lower 95.0%</i>	<i>Upper 95.0%</i>
Intercept	2.375	0.327	7.271	0.000	1.674	3.076	1.674	3.076
X Variable 1	-0.128	0.053	-2.410	0.030	-0.241	-0.014	-0.241	-0.014

Mann-Whitney-Wilcoxon Test

n ₁	16
n ₂	16
Observed T	360.000
Expected T	264.000
Std. Dev. T	26.533
Test Statistic	3.618
p-Value (lower)	0.999852
p-Value (upper)	0.000
p-Value (two ta	0.000
Reject H ₀ , if p-Value < 0.05	
Significant Diff? Yes	
H ₀ : Influent and Effluent Concentration is Same	
H _a : Influent and Effluent Concentration is Differ	

60~120 μ m Solids Influent vs. Effluent Probability in 95% Confidence Interval

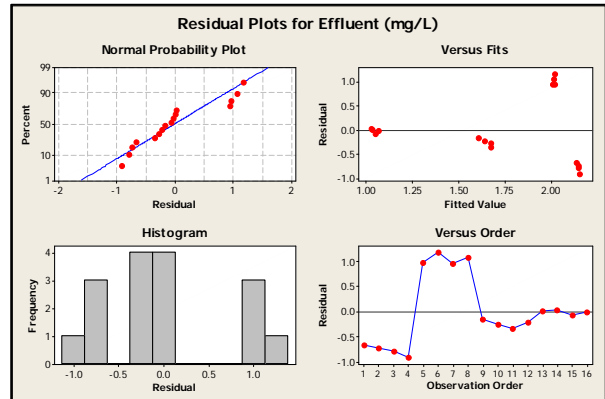
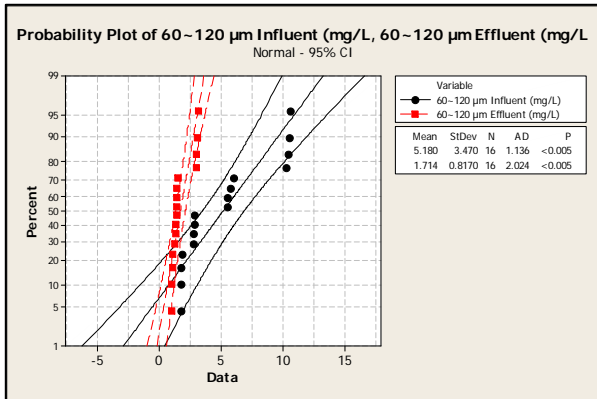
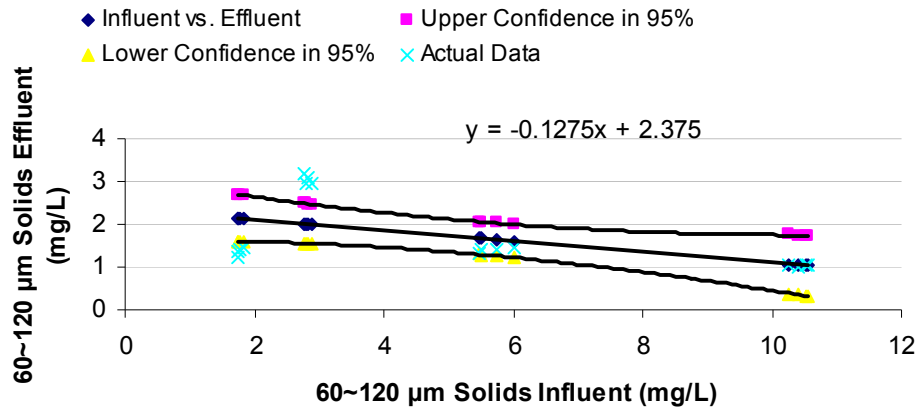

Appendix G.8: Sand Media 25gpm 120-250 μm Probability Analysis Detail

SUMMARY OUTPUT

<i>Regression Statistics</i>	
Multiple R	0.223
R Square	0.050
Adjusted R Square	-0.018
Standard Error	0.668
Observations	16.000

ANOVA						
	<i>df</i>	<i>SS</i>	<i>MS</i>	<i>F</i>	<i>Significance F</i>	
Regression	1.000	0.327	0.327	0.733	0.406	
Residual	14.000	6.240	0.446			
Total	15.000	6.567				

	<i>Coefficients</i>	<i>Standard Error</i>	<i>t Stat</i>	<i>P-value</i>	<i>Lower 95%</i>	<i>Upper 95%</i>	<i>Lower 95.0%</i>	<i>Upper 95.0%</i>
Intercept	0.546	0.275	1.987	0.067	-0.043	1.134	-0.043	1.134
X Variable 1	0.082	0.096	0.856	0.406	-0.123	0.287	-0.123	0.287

Mann-Whitney-Wilcoxon Test

n_1	16
n_2	16
Observed T	328.000
Expected T	264.000
Std. Dev. T	26.533
Test Statistic	2.412
p-Value (lower)	0.992069
p-Value (upper)	0.008
p-Value (two ta	0.016
Reject H_0 , if p-Value < 0.05	
Significant Diff? Yes	
H_0 : Influent and Effluent Concentration is Same	
H_a : Influent and Effluent Concentration is Differ	

120~250 μm Solids Influent vs. Effluent Probability in 95% Confidence Interval

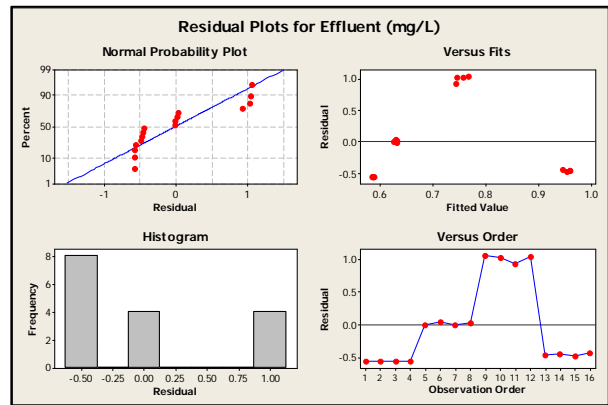
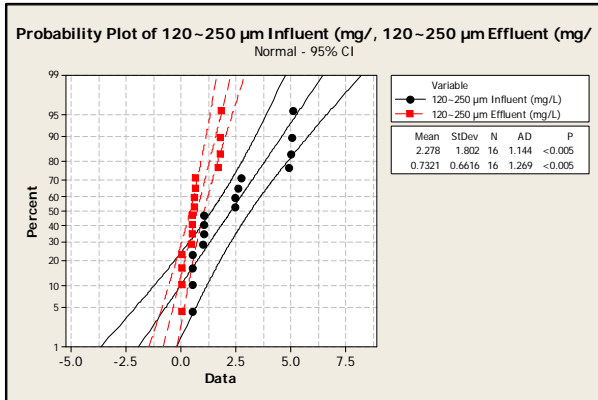
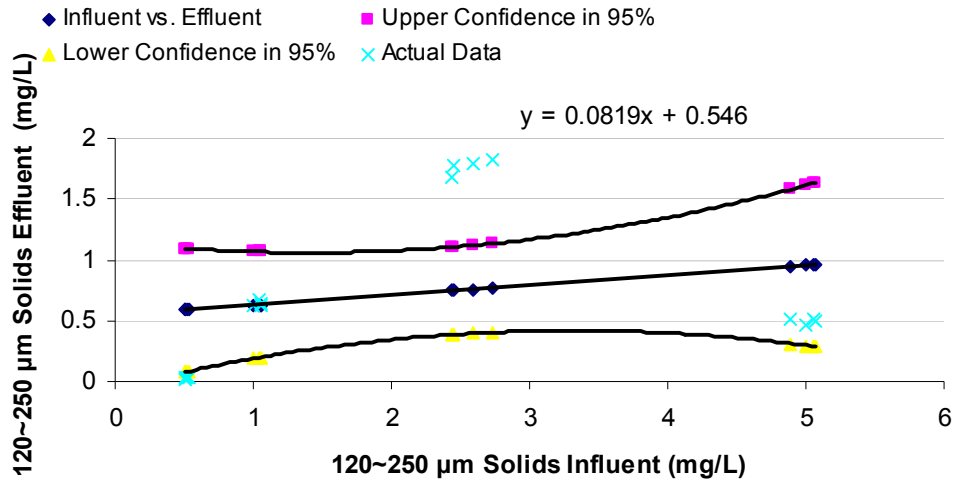

Appendix G.9: Sand Media 25gpm 250-1180 μm Probability Analysis Detail

SUMMARY OUTPUT

<i>Regression Statistics</i>	
Multiple R	1
R Square	1
Adjusted R Square	1
Standard Error	0
Observations	16

ANOVA

	<i>df</i>	<i>SS</i>	<i>MS</i>	<i>F</i>	<i>Significance F</i>
Regression	1	0	0	#NUM!	#NUM!
Residual	14	0	0		
Total	15	0			

	<i>Coefficients</i>	<i>Standard Error</i>	<i>t Stat</i>	<i>P-value</i>	<i>Lower 95%</i>	<i>Upper 95%</i>	<i>Lower 90.0%</i>	<i>Upper 90.0%</i>
Intercept	0	0	65535	#NUM!	0	0	0	0
X Variable 1	0	0	65535	#NUM!	0	0	0	0

Mann-Whitney-Wilcoxon Test

n_1	16
n_2	16
Observed T	392.000
Expected T	264.000
Std. Dev. T	26.533
Test Statistic	4.824
p-Value (lower)	0.999999
p-Value (upper)	0.000
p-Value (two ta	0.000
Reject H_0 , if p-Value < 0.05	
Significant Diff? Yes	
H_0 : Influent and Effluent Concentration is Same	
H_a : Influent and Effluent Concentration is Differ	

250~1180 μm Solids Influent vs. Effluent Probability in 95% Confidence Interval

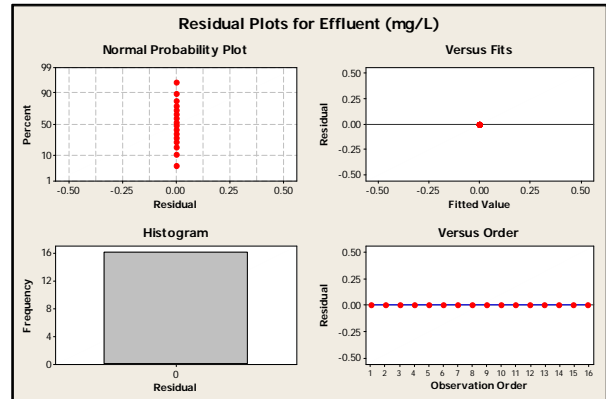
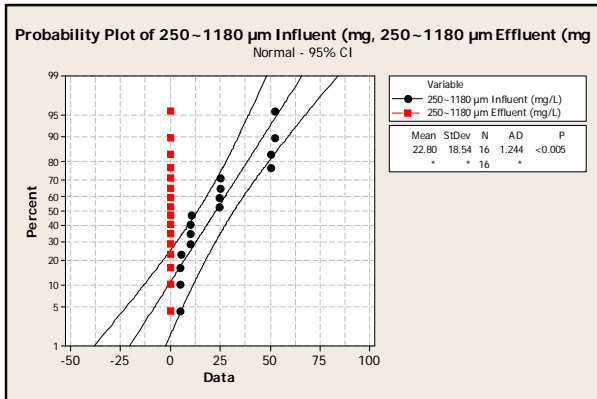
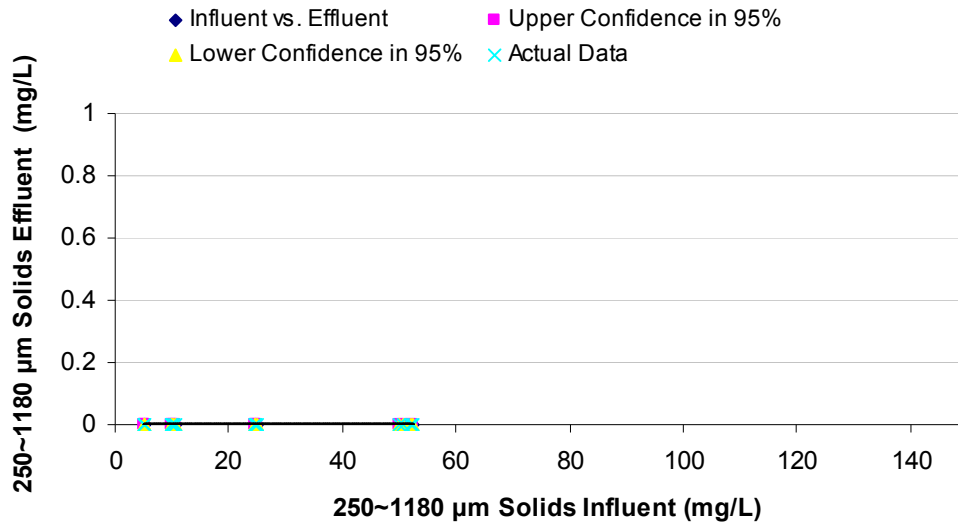

Appendix G.10: Sand Media 25gpm >1180 µm Probability Analysis Detail

SUMMARY OUTPUT

<i>Regression Statistics</i>	
Multiple R	1
R Square	1
Adjusted R Square	1
Standard Error	0
Observations	16

ANOVA

	<i>df</i>	<i>SS</i>	<i>MS</i>	<i>F</i>	<i>Significance F</i>
Regression	1	0	0	#NUM!	#NUM!
Residual	14	0	0		
Total	15	0			

	<i>Coefficients</i>	<i>Standard Error</i>	<i>t Stat</i>	<i>P-value</i>	<i>Lower 95%</i>	<i>Upper 95%</i>	<i>Lower 90.0%</i>	<i>Upper 90.0%</i>
Intercept	0	0	65535	#NUM!	0	0	0	0
X Variable 1	0	0	65535	#NUM!	0	0	0	0

Mann-Whitney-Wilcoxon Test

n ₁	16
n ₂	16
Observed T	392.000
Expected T	264.000
Std. Dev. T	26.533
Test Statistic	4.824
p-Value (lower tail)	0.999999
p-Value (upper tail)	0.000
p-Value (two-tailed)	0.000
Reject H ₀ , if p-Value < 0.05	
Significant Diff? Yes	
H ₀ : Influent and Effluent Concentration is Same	
H _a : Influent and Effluent Concentration is Differ	

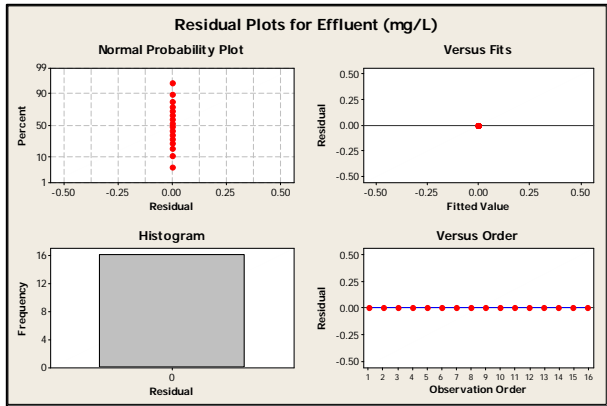
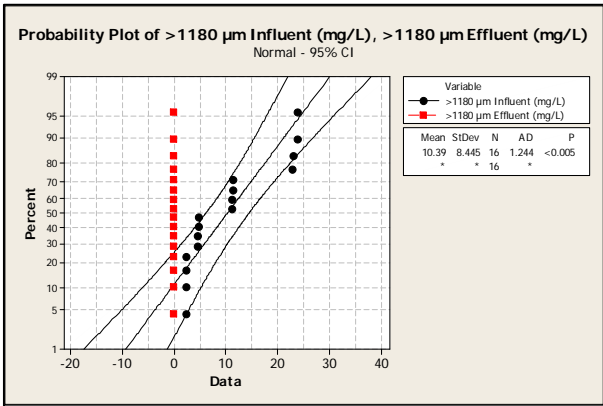
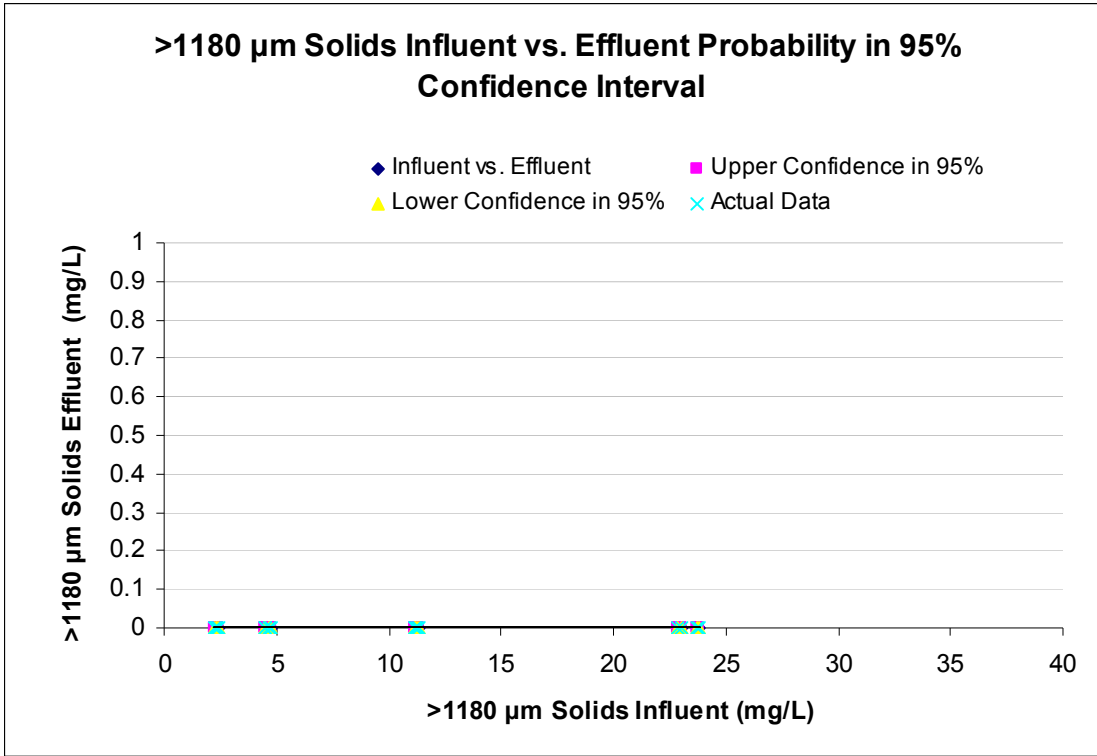

Appendix G.11: Sand Media 75gpm TSS Probability Analysis Detail

SUMMARY OUTPUT

<i>Regression Statistics</i>	
Multiple R	0.989
R Square	0.978
Adjusted R Square	0.976
Standard Error	5.531
Observations	16.000

ANOVA					
	<i>df</i>	<i>SS</i>	<i>MS</i>	<i>F</i>	<i>Significance F</i>
Regression	1.000	18951.335	18951.335	619.420	0.000
Residual	14.000	426.334	30.595		
Total	15.000	19379.669			

	<i>Coefficients</i>	<i>Standard Error</i>	<i>t Stat</i>	<i>P-value</i>	<i>Lower 95%</i>	<i>Upper 95%</i>	<i>Lower 95.0%</i>	<i>Upper 95.0%</i>
Intercept	11.487	2.294	5.007	0.000	6.566	16.408	6.566	16.408
X Variable 1	0.199	0.008	24.888	0.000	0.182	0.216	0.182	0.216

Mann-Whitney-Wilcoxon Test

n_1	16
n_2	16
Observed T	345.000
Expected T	264.000
Std. Dev. T	26.533
Test Statistic	3.053
p-Value (lower tail)	0.998866
p-Value (upper tail)	0.001
p-Value (two tail)	0.002 Reject H_0 , if p-Value < 0.05
Significant Diff?	Yes
H_0 : Influent and Effluent Concentration is Same	
H_a : Influent and Effluent Concentration is Differ	

TSS Influent vs. Effluent Probability in 95% Confidence Interval

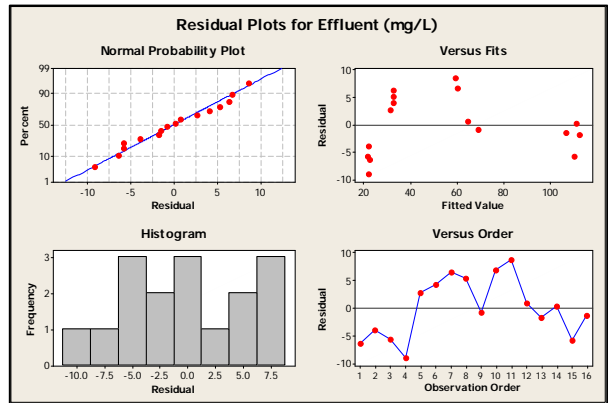
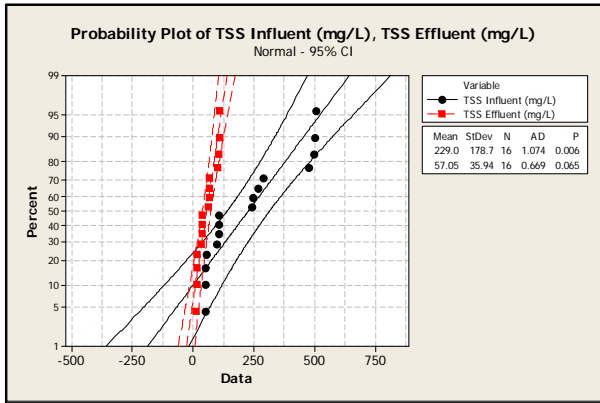
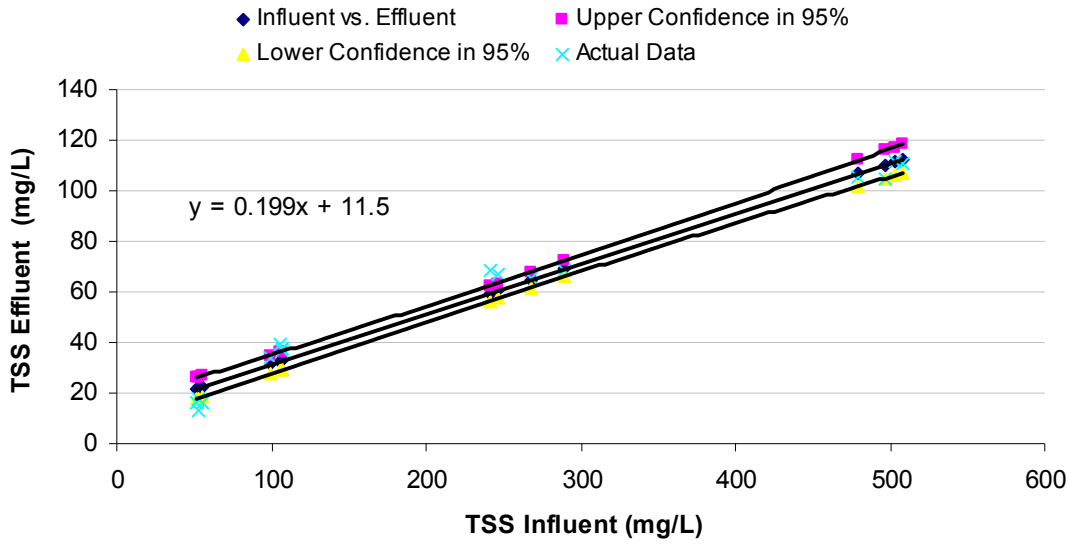

Appendix G.12: Sand Media 75gpm TDS Probability Analysis Detail

SUMMARY OUTPUT

<i>Regression Statistics</i>	
Multiple R	0.993
R Square	0.986
Adjusted R Square	0.919
Standard Error	11.140
Observations	16.000

ANOVA					
	<i>df</i>	<i>SS</i>	<i>MS</i>	<i>F</i>	<i>Significance F</i>
Regression	1.000	128265.510	128265.510	1033.571	0.000
Residual	15.000	1861.490	124.099		
Total	16.000	130127.000			

	<i>Coefficients</i>	<i>Standard Error</i>	<i>t Stat</i>	<i>P-value</i>	<i>Lower 95%</i>	<i>Upper 95%</i>	<i>Lower 95.0%</i>	<i>Upper 95.0%</i>
Intercept	0.000	#N/A	#N/A	#N/A	#N/A	#N/A	#N/A	#N/A
X Variable 1	0.716	0.022	32.149	0.000	0.669	0.764	0.669	0.764

Mann-Whitney-Wilcoxon Test

n_1	16
n_2	16
Observed T	392.000
Expected T	264.000
Std. Dev. T	26.533
Test Statistic	4.824
p-Value (lower tail)	0.999999
p-Value (upper tail)	0.000
p-Value (two tail)	0.000
Reject H_0 , if p-Value < 0.05	
Significant Diff? Yes	
H_0 : Influent and Effluent Concentration is Same	
H_a : Influent and Effluent Concentration is Differ	

TDS Influent vs. Effluent Probability in 95% Confidence Interval

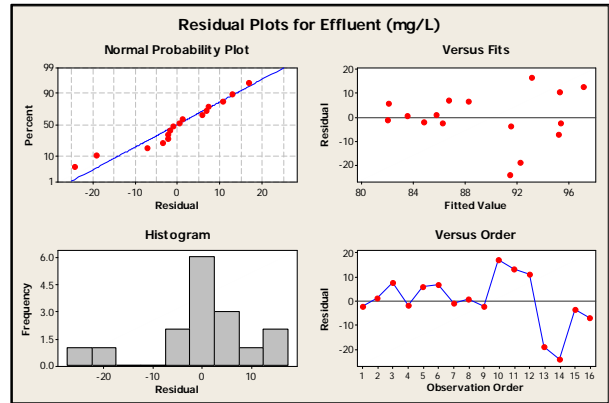
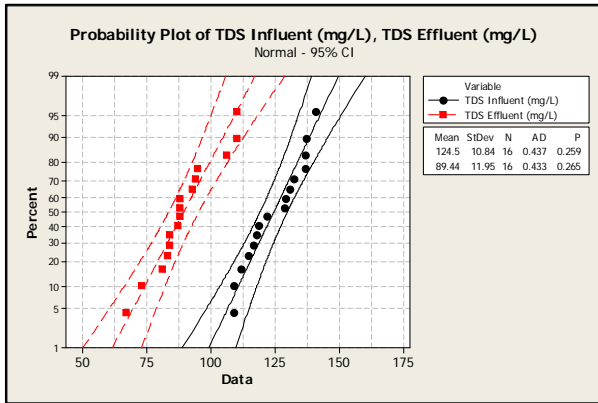
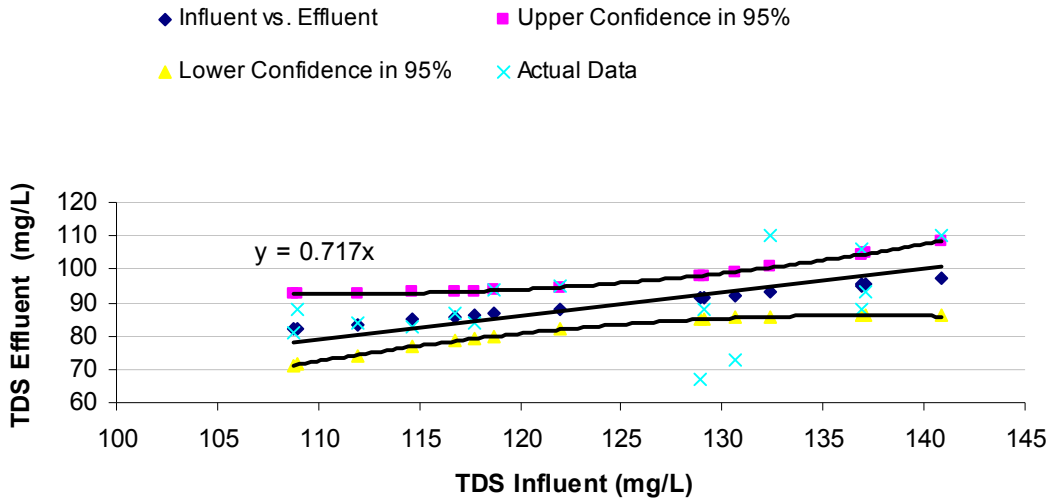

Appendix G.13: Sand Media 75gpm 0.45-3 μm Probability Analysis Detail

SUMMARY OUTPUT

<i>Regression Statistics</i>	
Multiple R	0.993
R Square	0.986
Adjusted R Square	0.919
Standard Error	0.710
Observations	16.000

ANOVA					
	<i>df</i>	<i>SS</i>	<i>MS</i>	<i>F</i>	<i>Significance F</i>
Regression	1.000	524.041	524.041	1039.078	0.000
Residual	15.000	7.565	0.504		
Total	16.000	531.606			

	<i>Coefficients</i>	<i>Standard Error</i>	<i>t Stat</i>	<i>P-value</i>	<i>Lower 95%</i>	<i>Upper 95%</i>	<i>Lower 95.0%</i>	<i>Upper 95.0%</i>
Intercept	0.000	#N/A	#N/A	#N/A	#N/A	#N/A	#N/A	#N/A
X Variable 1	0.291	0.009	32.235	0.000	0.271	0.310	0.271	0.310

Mann-Whitney-Wilcoxon Test

n_1	16
n_2	16
Observed T	344.000
Expected T	264.000
Std. Dev. T	26.533
Test Statistic	3.015
p-Value (lower tail)	0.998716
p-Value (upper tail)	0.001
p-Value (two tail)	0.003
Reject H_0 , if p-Value < 0.05	
Significant Diff? Yes	
H_0 : Influent and Effluent Concentration is Same	
H_a : Influent and Effluent Concentration is Differ	

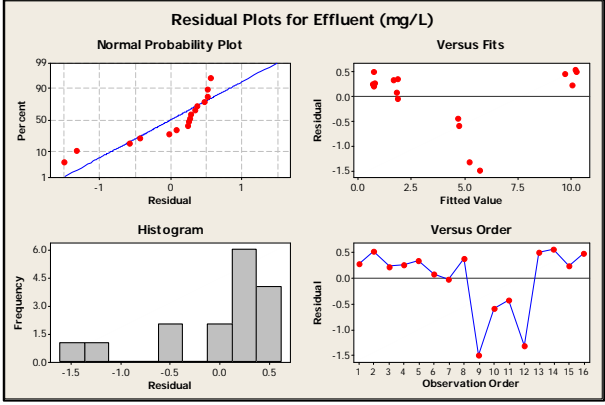
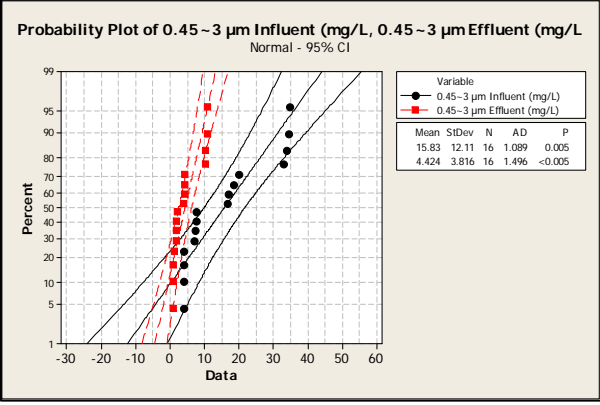
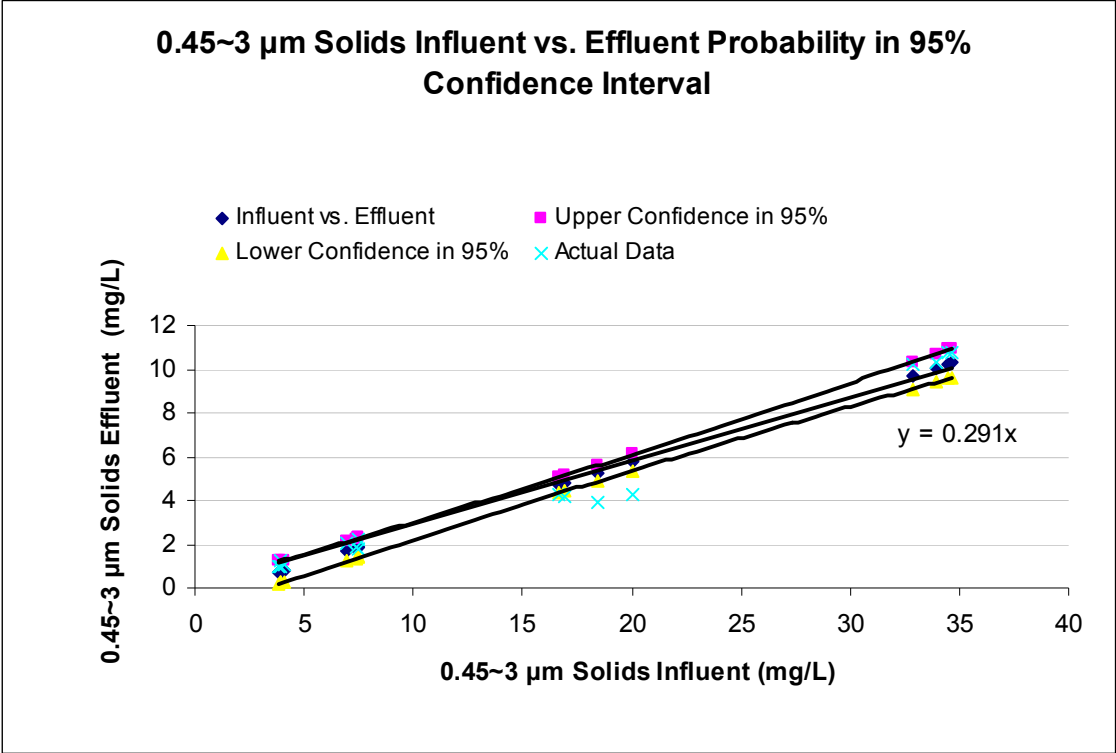

Appendix G.14: Sand Media 75gpm 3-12 μ m Probability Analysis Detail

SUMMARY OUTPUT

<i>Regression Statistics</i>	
Multiple R	0.998
R Square	0.996
Adjusted R Square	0.929
Standard Error	1.908
Observations	16.000

ANOVA					
	<i>df</i>	<i>SS</i>	<i>MS</i>	<i>F</i>	<i>Significance F</i>
Regression	1.000	12350.350	12350.350	3394.088	0.000
Residual	15.000	54.582	3.639		
Total	16.000	12404.932			

	<i>Coefficients</i>	<i>Standard Error</i>	<i>t Stat</i>	<i>P-value</i>	<i>Lower 95%</i>	<i>Upper 95%</i>	<i>Lower 95.0%</i>	<i>Upper 95.0%</i>
Intercept	0.000	#N/A	#N/A	#N/A	#N/A	#N/A	#N/A	#N/A
X Variable 1	0.371	0.006	58.259	0.000	0.357	0.384	0.357	0.384

Mann-Whitney-Wilcoxon Test

n_1	16
n_2	16
Observed T	339.000
Expected T	264.000
Std. Dev. T	26.533
Test Statistic	2.827
p-Value (lower tail)	0.997648
p-Value (upper tail)	0.002
p-Value (two tail)	0.005
Reject H_0 , if p-Value < 0.05	
Significant Diff?	Yes
H_0 : Influent and Effluent Concentration is Same	
H_a : Influent and Effluent Concentration is Differ	

3~12 μm Solids Influent vs. Effluent Probability in 95% Confidence Interval

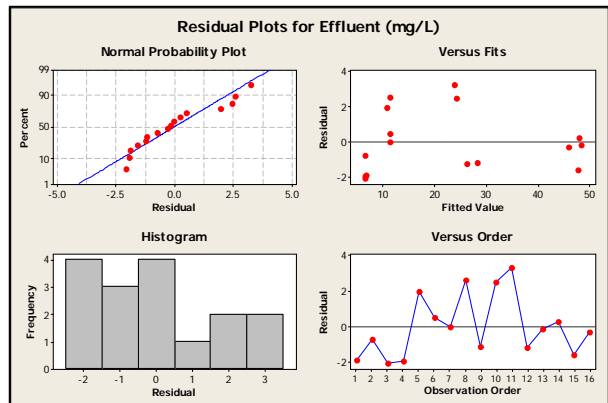
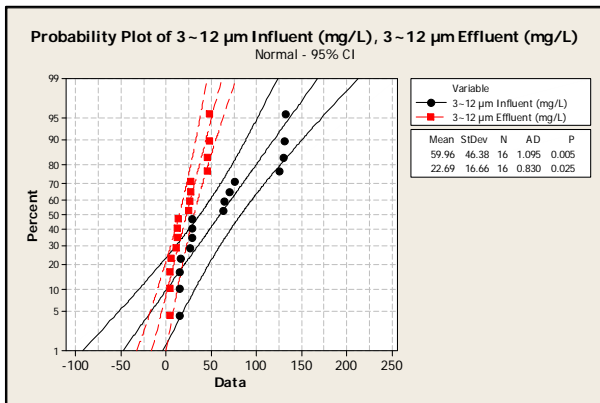
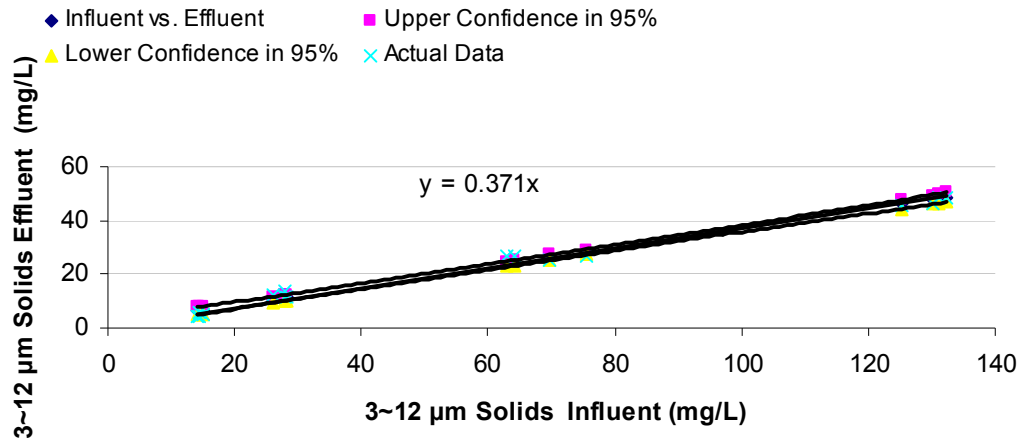

Appendix G.15: Sand Media 75gpm 12-30 μm Probability Analysis Detail

SUMMARY OUTPUT

<i>Regression Statistics</i>	
Multiple R	0.995
R Square	0.990
Adjusted R Square	0.924
Standard Error	2.448
Observations	16.000

ANOVA					
	<i>df</i>	<i>SS</i>	<i>MS</i>	<i>F</i>	<i>Significance F</i>
Regression	1.000	9165.766	9165.766	1529.465	0.000
Residual	15.000	89.892	5.993		
Total	16.000	9255.658			

	<i>Coefficients</i>	<i>Standard Error</i>	<i>t Stat</i>	<i>P-value</i>	<i>Lower 95%</i>	<i>Upper 95%</i>	<i>Lower 95.0%</i>	<i>Upper 95.0%</i>
Intercept	0.000	#N/A	#N/A	#N/A	#N/A	#N/A	#N/A	#N/A
X Variable 1	0.258	0.007	39.108	0.000	0.244	0.272	0.244	0.272

Mann-Whitney-Wilcoxon Test

n_1	16
n_2	16
Observed T	344.000
Expected T	264.000
Std. Dev. T	26.533
Test Statistic	3.015
p-Value (lower tail)	0.998716
p-Value (upper tail)	0.001
p-Value (two tail)	0.003
Reject H_0 , if p-Value < 0.05	
Significant Diff? Yes	
H_0 : Influent and Effluent Concentration is Same	
H_a : Influent and Effluent Concentration is Differ	

12~30 μm Solids Influent vs. Effluent Probability in 95% Confidence Interval

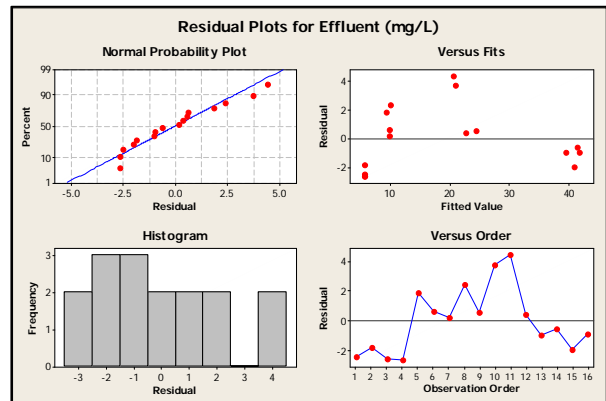
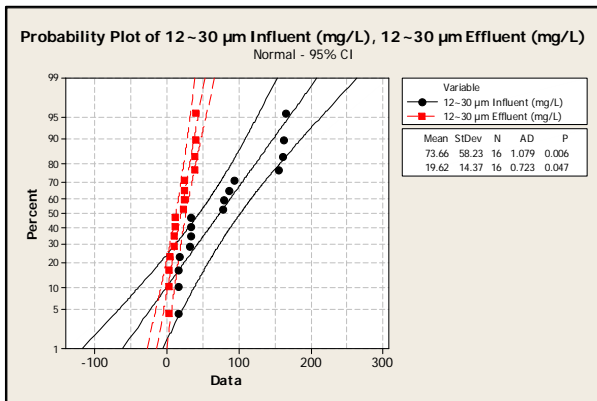
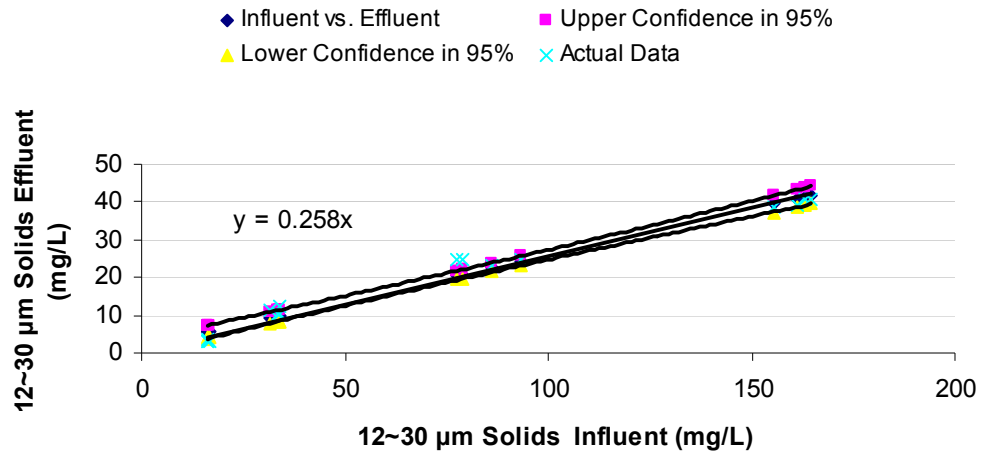

Appendix G.16: Sand Media 75gpm 30-60 µm Probability Analysis Detail

SUMMARY OUTPUT

<i>Regression Statistics</i>	
Multiple R	0.917
R Square	0.841
Adjusted R Square	0.829
Standard Error	1.180
Observations	16.000

ANOVA

	<i>df</i>	<i>SS</i>	<i>MS</i>	<i>F</i>	<i>Significance F</i>
Regression	1.000	102.801	102.801	73.785	0.000
Residual	14.000	19.505	1.393		
Total	15.000	122.306			

	<i>Coefficients</i>	<i>Standard Error</i>	<i>t Stat</i>	<i>P-value</i>	<i>Lower 95%</i>	<i>Upper 95%</i>	<i>Lower 95.0%</i>	<i>Upper 95.0%</i>
Intercept	1.651	0.486	3.399	0.004	0.609	2.693	0.609	2.693
X Variable 1	0.086	0.010	8.590	0.000	0.064	0.107	0.064	0.107

Mann-Whitney-Wilcoxon Test

n ₁	16
n ₂	16
Observed T	378.000
Expected T	264.000
Std. Dev. T	26.533
Test Statistic	4.297
p-Value (lower tail)	0.999991
p-Value (upper tail)	0.000
p-Value (two-tailed)	0.000
Reject H ₀ , if p-Value < 0.05	
Significant Diff? Yes	
H ₀ : Influent and Effluent Concentration is Same	
H _a : Influent and Effluent Concentration is Differ	

30~60 μm Solids Influent vs. Effluent Probability in 95% Confidence Interval

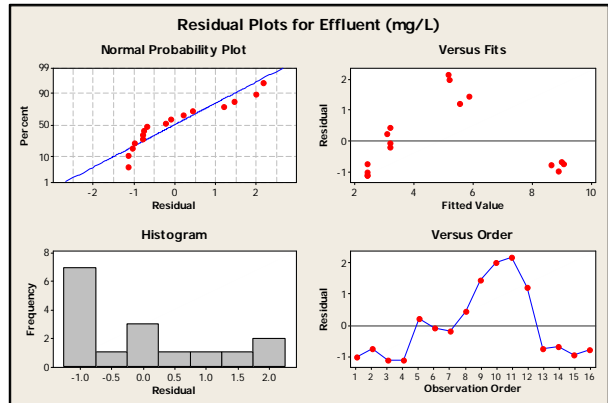
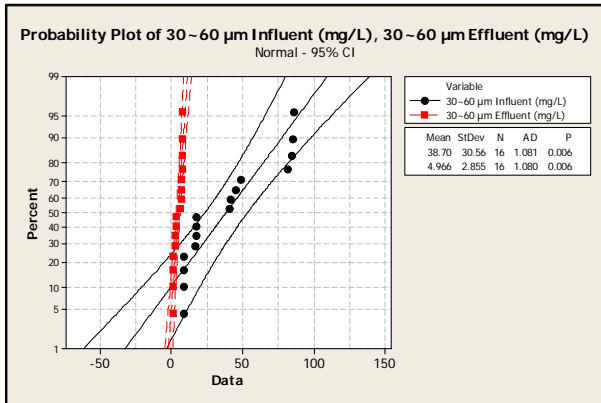
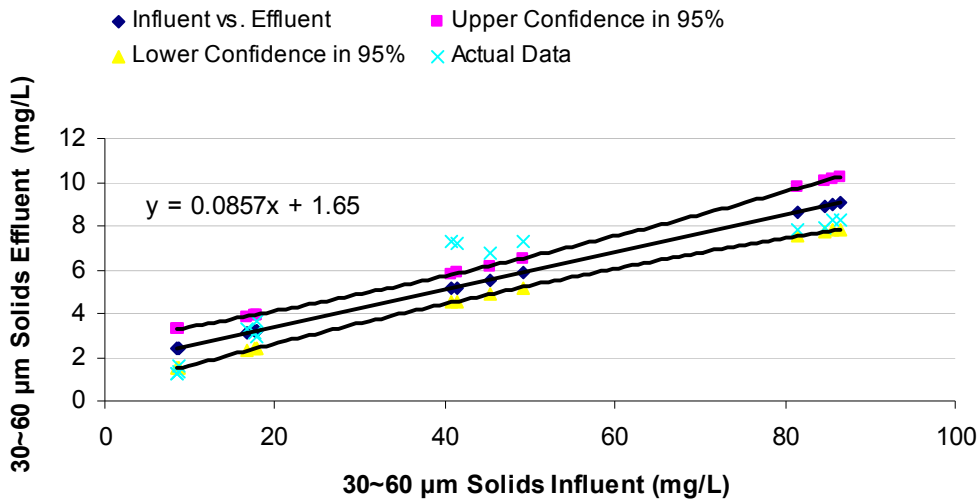

Appendix G.17: Sand Media 75gpm 60-120 μm Probability Analysis Detail

SUMMARY OUTPUT

<i>Regression Statistics</i>	
Multiple R	0.309
R Square	0.096
Adjusted R Square	0.031
Standard Error	0.263
Observations	16.000

ANOVA						
	<i>df</i>	<i>SS</i>	<i>MS</i>	<i>F</i>	<i>Significance F</i>	
Regression	1.000	0.102	0.102	1.480	0.244	
Residual	14.000	0.969	0.069			
Total	15.000	1.071				

	<i>Coefficients</i>	<i>Standard Error</i>	<i>t Stat</i>	<i>P-value</i>	<i>Lower 95%</i>	<i>Upper 95%</i>	<i>Lower 95.0%</i>	<i>Upper 95.0%</i>
Intercept	0.633	0.110	5.748	0.000	0.397	0.869	0.397	0.869
X Variable 1	0.022	0.018	1.217	0.244	-0.017	0.062	-0.017	0.062

Mann-Whitney-Wilcoxon Test

n_1	16
n_2	16
Observed T	392.000
Expected T	264.000
Std. Dev. T	26.533
Test Statistic	4.824
p-Value (lower)	0.999999
p-Value (upper)	0.000
p-Value (two ta	0.000
Reject H_0 , if p-Value < 0.05	
Significant Diff? Yes	
H_0 : Influent and Effluent Concentration is Same	
H_a : Influent and Effluent Concentration is Differ	

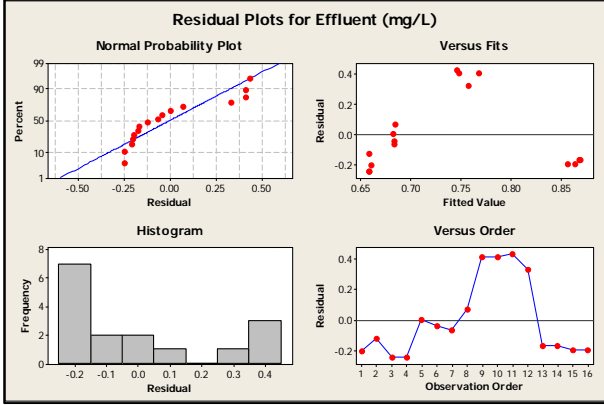
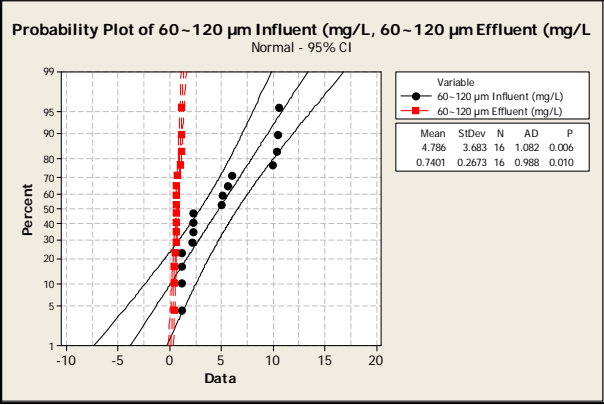
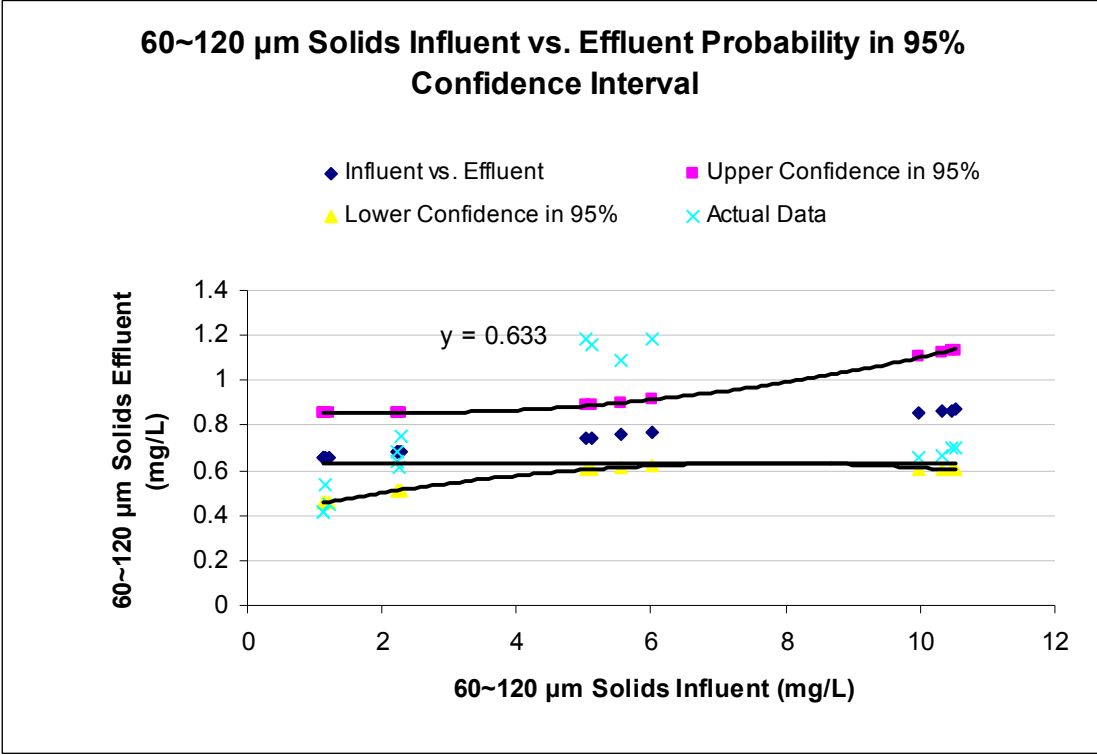

Appendix G.18: Sand Media 75gpm 120-250 μm Probability Analysis Detail

SUMMARY OUTPUT

<i>Regression Statistics</i>	
Multiple R	0.223
R Square	0.050
Adjusted R Square	-0.018
Standard Error	0.668
Observations	16.000

ANOVA

	<i>df</i>	<i>SS</i>	<i>MS</i>	<i>F</i>	<i>Significance F</i>
Regression	1.000	0.327	0.327	0.733	0.406
Residual	14.000	6.240	0.446		
Total	15.000	6.567			

	<i>Coefficients</i>	<i>Standard Error</i>	<i>t Stat</i>	<i>P-value</i>	<i>Lower 95%</i>	<i>Upper 95%</i>	<i>Lower 95.0%</i>	<i>Upper 95.0%</i>
Intercept	0.546	0.275	1.987	0.067	-0.043	1.134	-0.043	1.134
X Variable 1	0.082	0.096	0.856	0.406	-0.123	0.287	-0.123	0.287

Mann-Whitney-Wilcoxon Test

n_1	16
n_2	16
Observed T	392.000
Expected T	264.000
Std. Dev. T	26.533
Test Statistic	4.824
p-Value (lower tail)	0.999999
p-Value (upper tail)	0.000
p-Value (two-tailed)	0.000
Reject H_0 , if p-Value < 0.05	
Significant Diff? Yes	
H_0 : Influent and Effluent Concentration is Same	
H_a : Influent and Effluent Concentration is Differ	

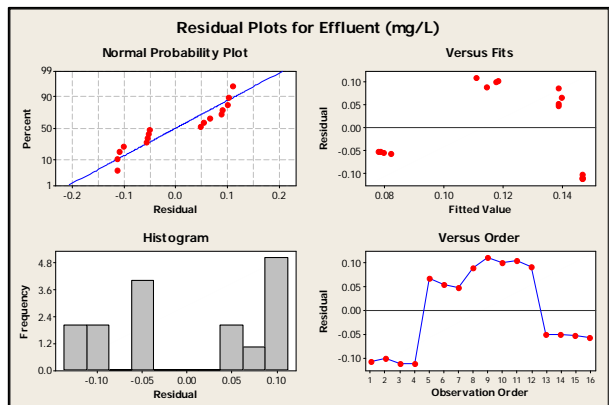
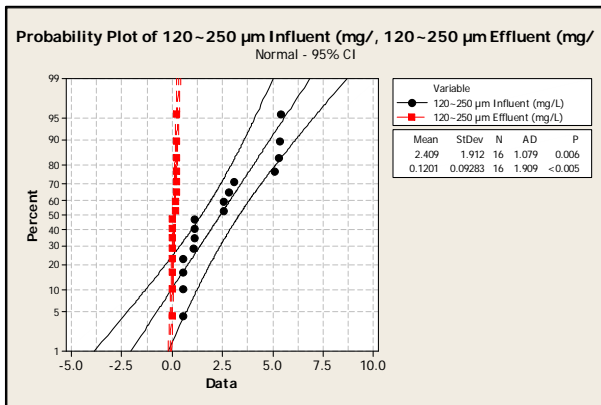
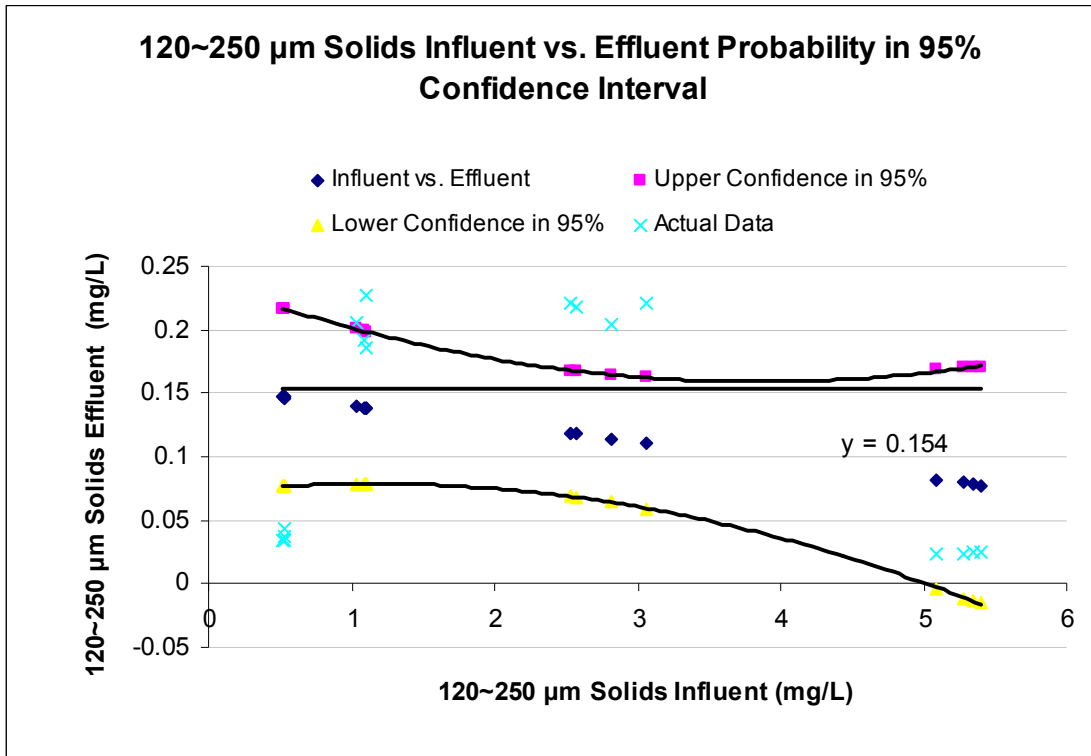

Appendix G.19: Sand Media 75gpm 250-1180 μm Probability Analysis Detail

SUMMARY OUTPUT

<i>Regression Statistics</i>	
Multiple R	1
R Square	1
Adjusted R Square	1
Standard Error	0
Observations	16

ANOVA

	<i>df</i>	<i>SS</i>	<i>MS</i>	<i>F</i>	<i>Significance F</i>
Regression	1	0	0	#NUM!	#NUM!
Residual	14	0	0		
Total	15	0			

	<i>Coefficients</i>	<i>Standard Error</i>	<i>t Stat</i>	<i>P-value</i>	<i>Lower 95%</i>	<i>Upper 95%</i>	<i>Lower 90.0%</i>	<i>Upper 90.0%</i>
Intercept	0	0	65535	#NUM!	0	0	0	0
X Variable 1	0	0	65535	#NUM!	0	0	0	0

Mann-Whitney-Wilcoxon Test

n_1	16
n_2	16
Observed T	392.000
Expected T	264.000
Std. Dev. T	26.533
Test Statistic	4.824
p-Value (lower tail)	0.999999
p-Value (upper tail)	0.000
p-Value (two-tailed)	0.000
Reject H_0 , if p-Value < 0.05	
Significant Diff? Yes	
H_0 : Influent and Effluent Concentration is Same	
H_a : Influent and Effluent Concentration is Differ	

250~1180 μm Solids Influent vs. Effluent Probability in 95% Confidence Interval

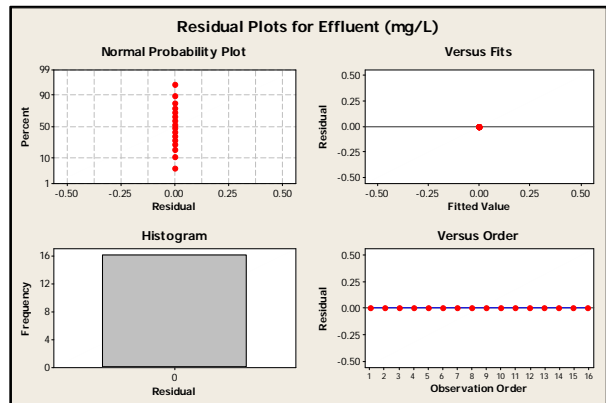
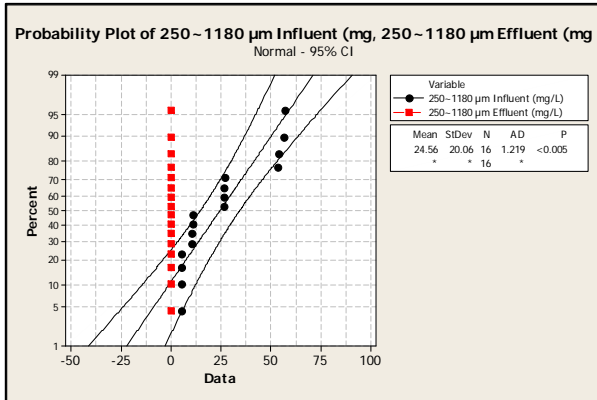
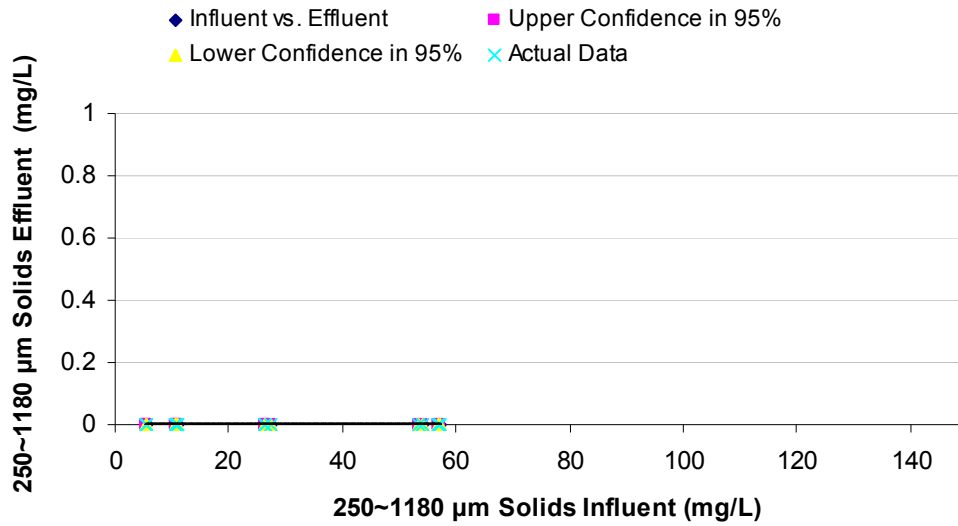

Appendix G.20: Sand Media 75gpm >1180 µm Probability Analysis Detail

SUMMARY OUTPUT

<i>Regression Statistics</i>	
Multiple R	1
R Square	1
Adjusted R Square	1
Standard Error	0
Observations	16

ANOVA

	<i>df</i>	<i>SS</i>	<i>MS</i>	<i>F</i>	<i>Significance F</i>
Regression	1	0	0	#NUM!	#NUM!
Residual	14	0	0		
Total	15	0			

	<i>Coefficients</i>	<i>Standard Error</i>	<i>t Stat</i>	<i>P-value</i>	<i>Lower 95%</i>	<i>Upper 95%</i>	<i>Lower 90.0%</i>	<i>Upper 90.0%</i>
Intercept	0	0	65535	#NUM!	0	0	0	0
X Variable 1	0	0	65535	#NUM!	0	0	0	0

Mann-Whitney-Wilcoxon Test

n ₁	16
n ₂	16
Observed T	392.000
Expected T	264.000
Std. Dev. T	26.533
Test Statistic	4.824
p-Value (lower tail)	0.999999
p-Value (upper tail)	0.000
p-Value (two-tailed)	0.000
Reject H ₀ , if p-Value < 0.05	
Significant Diff? Yes	
H ₀ : Influent and Effluent Concentration is Same	
H _a : Influent and Effluent Concentration is Differ	

>1180 μm Solids Influent vs. Effluent Probability in 95% Confidence Interval

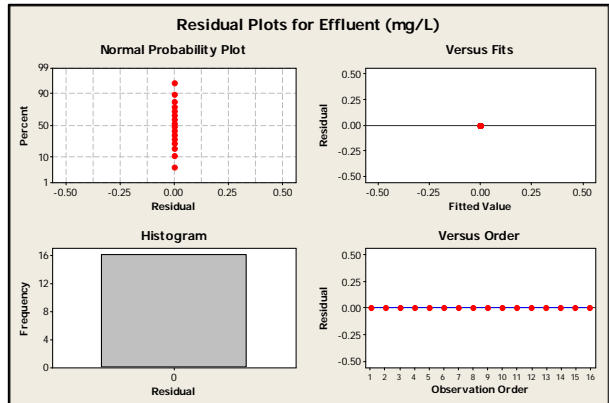
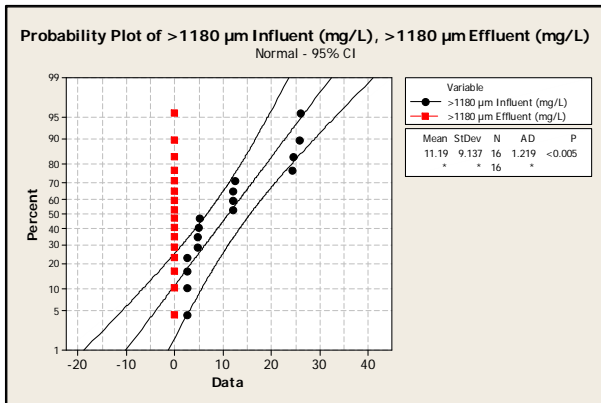
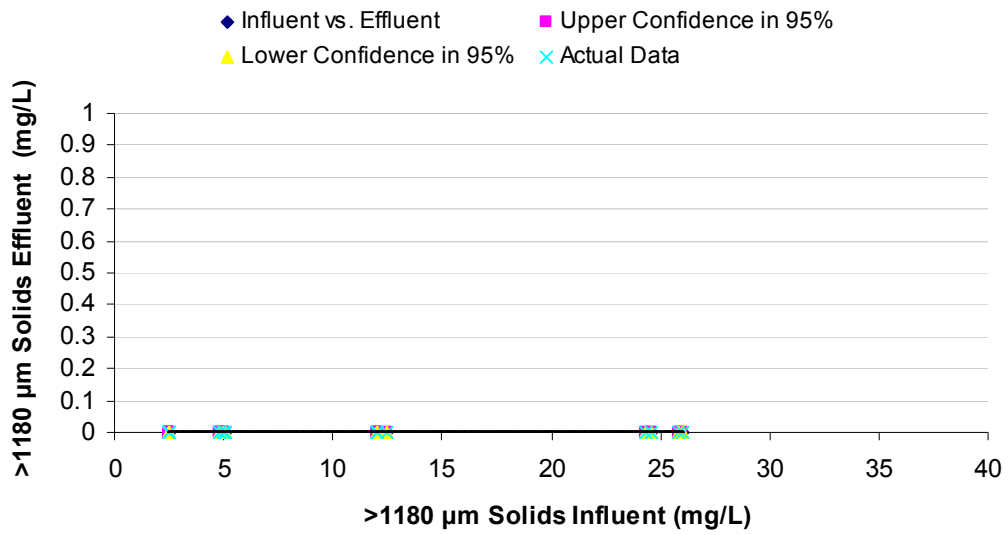

Appendix G.21: Sand Media 150gpm TSS Probability Analysis Detail

SUMMARY OUTPUT

<i>Regression Statistics</i>	
Multiple R	0.989
R Square	0.978
Adjusted R Square	0.976
Standard Error	5.521
Observations	16.000

ANOVA					
	<i>df</i>	<i>SS</i>	<i>MS</i>	<i>F</i>	<i>Significance F</i>
Regression	1.000	18952.945	18952.945	621.810	0.000
Residual	14.000	426.724	30.480		
Total	15.000	19379.669			

	<i>Coefficients</i>	<i>Standard Error</i>	<i>t Stat</i>	<i>P-value</i>	<i>Lower 95%</i>	<i>Upper 95%</i>	<i>Lower 95.0%</i>	<i>Upper 95.0%</i>
Intercept	11.934	2.276	5.244	0.000	7.054	16.815	7.054	16.815
X Variable 1	0.156	0.006	24.936	0.000	0.143	0.170	0.143	0.170

Mann-Whitney-Wilcoxon Test

n_1	16
n_2	16
Observed T	371.000
Expected T	264.000
Std. Dev. T	26.533
Test Statistic	4.033
p-Value (lower tail)	0.999972
p-Value (upper tail)	0.000
p-Value (two tail)	0.000
Reject H_0 , if p-Value < 0.05	
Significant Diff?	Yes
H_0 : Influent and Effluent Concentration is Same	
H_a : Influent and Effluent Concentration is Differ	

TSS Influent vs. Effluent Probability in 95% Confidence Interval

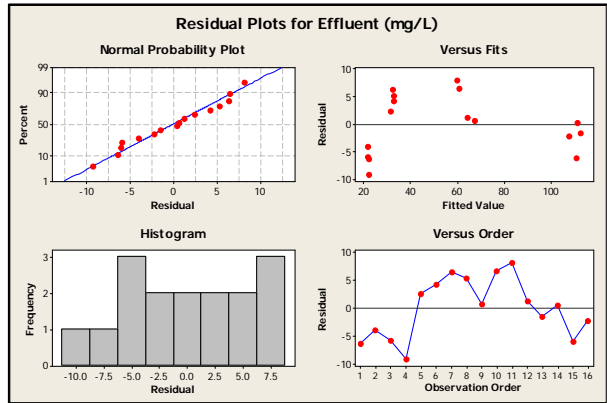
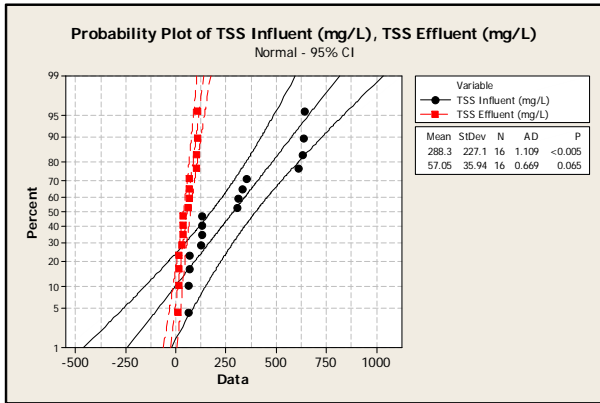
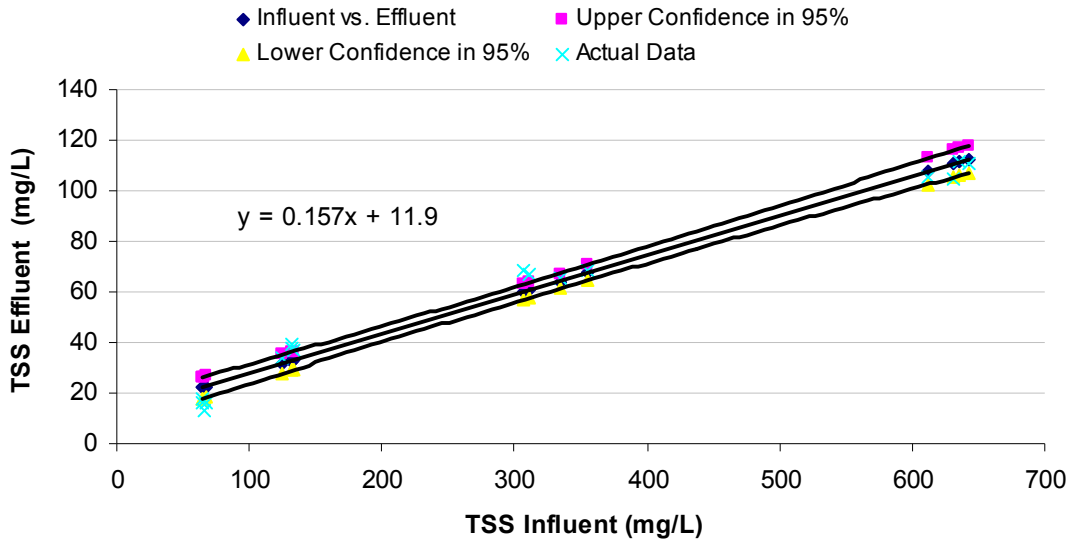

Appendix G.22: Sand Media 150gpm TDS Probability Analysis Detail

SUMMARY OUTPUT

<i>Regression Statistics</i>	
Multiple R	0.148
R Square	0.022
Adjusted R Square	-0.048
Standard Error	17.056
Observations	16.000

ANOVA					
	<i>df</i>	<i>SS</i>	<i>MS</i>	<i>F</i>	<i>Significance F</i>
Regression	1.000	91.715	91.715	0.315	0.583
Residual	14.000	4072.722	290.909		
Total	15.000	4164.437			

	<i>Coefficients</i>	<i>Standard Error</i>	<i>t Stat</i>	<i>P-value</i>	<i>Lower 95%</i>	<i>Upper 95%</i>	<i>Lower 95.0%</i>	<i>Upper 95.0%</i>
Intercept	92.964	51.555	1.803	0.093	-17.612	203.539	-17.612	203.539
X Variable 1	0.173	0.308	0.561	0.583	-0.487	0.833	-0.487	0.833

Mann-Whitney-Wilcoxon Test

n ₁	16
n ₂	16
Observed T	392.000
Expected T	264.000
Std. Dev. T	26.533
Test Statistic	4.824
p-Value (lower t	0.999999
p-Value (upper	0.000
p-Value (two ta	0.000
Reject H ₀ , if p-Value < 0.05	
Significant Diff? Yes	
H ₀ : Influent and Effluent Concentration is Same	
H _a : Influent and Effluent Concentration is Differ	

TDS Influent vs. Effluent Probability in 95% Confidence Interval

- ◆ Influent vs. Effluent
- ▲ Lower Confidence in 95%
- Upper Confidence in 95%
- × Actual Data

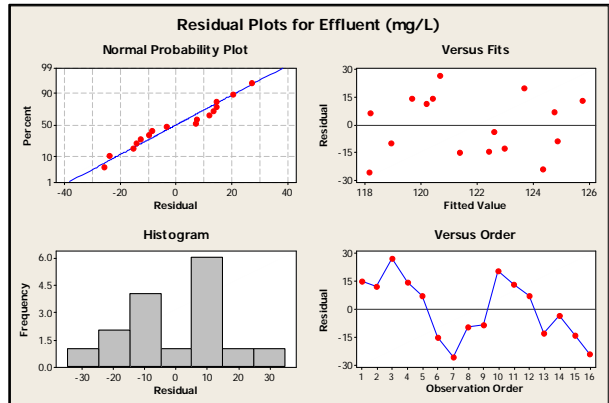
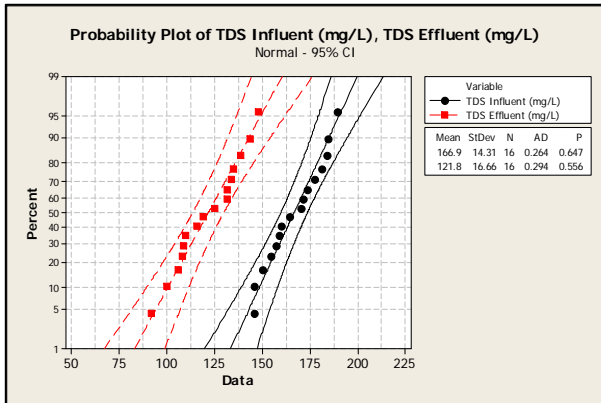
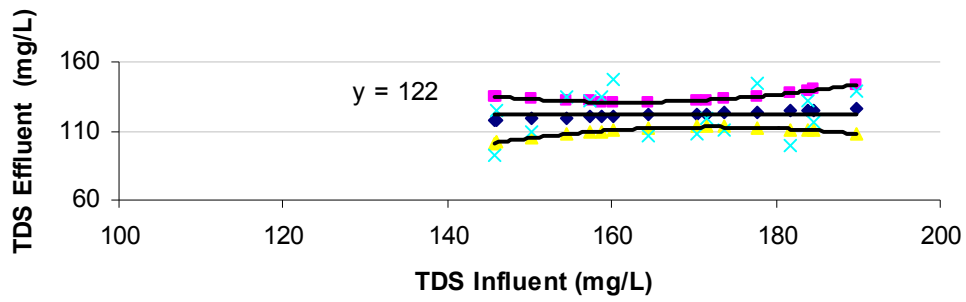

Appendix G.23: Sand Media 150gpm 0.45-3 μm Probability Analysis Detail

SUMMARY OUTPUT

<i>Regression Statistics</i>	
Multiple R	0.993
R Square	0.986
Adjusted R Square	0.985
Standard Error	0.196
Observations	16.000

ANOVA

	<i>df</i>	<i>SS</i>	<i>MS</i>	<i>F</i>	<i>Significance F</i>
Regression	1.000	38.427	38.427	995.524	0.000
Residual	14.000	0.540	0.039		
Total	15.000	38.967			

	<i>Coefficients</i>	<i>Standard Error</i>	<i>t Stat</i>	<i>P-value</i>	<i>Lower 95%</i>	<i>Upper 95%</i>	<i>Lower 95.0%</i>	<i>Upper 95.0%</i>
Intercept	1.070	0.082	13.046	0.000	0.894	1.246	0.894	1.246
X Variable 1	0.104	0.003	31.552	0.000	0.097	0.111	0.097	0.111

Mann-Whitney-Wilcoxon Test

n_1	16
n_2	16
Observed T	376.000
Expected T	264.000
Std. Dev. T	26.533
Test Statistic	4.221
p-Value (lower t	0.999988
p-Value (upper t	0.000
p-Value (two tai	0.000
Reject H_0 , if p-Value < 0.05	
Significant Diff? Yes	
H_0 : Influent and Effluent Concentration is Same	
H_a : Influent and Effluent Concentration is Differ	

0.45~3 μm Solids Influent vs. Effluent Probability in 95% Confidence Interval

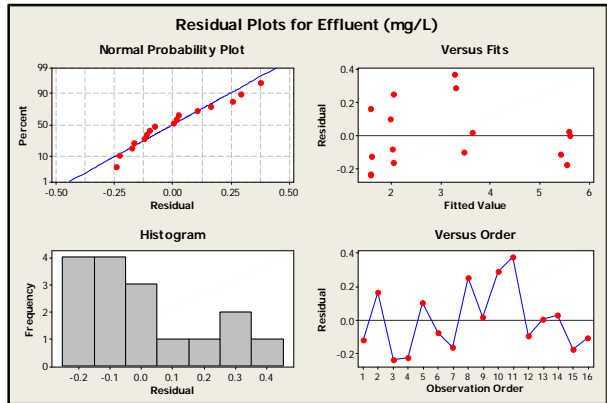
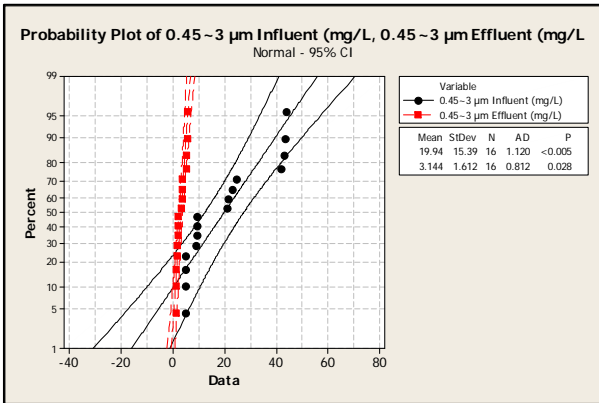
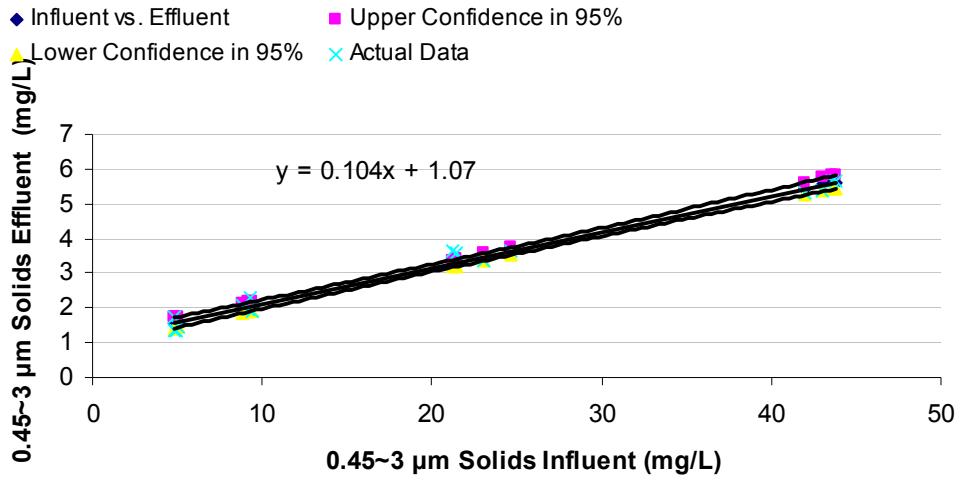

Appendix G.24: Sand Media 150gpm 3-12 μm Probability Analysis Detail

SUMMARY OUTPUT

<i>Regression Statistics</i>	
Multiple R	0.968
R Square	0.936
Adjusted R Square	0.932
Standard Error	2.727
Observations	16.000

ANOVA

	<i>df</i>	<i>SS</i>	<i>MS</i>	<i>F</i>	<i>Significance F</i>
Regression	1.000	1529.551	1529.551	206.669	0.000
Residual	14.000	104.117	7.437		
Total	15.000	1633.668			

	<i>Coefficients</i>	<i>Standard Error</i>	<i>t Stat</i>	<i>P-value</i>	<i>Lower 95%</i>	<i>Upper 95%</i>	<i>Lower 95.0%</i>	<i>Upper 95.0%</i>
Intercept	2.596	1.124	2.309	0.037	0.185	5.007	0.185	5.007
X Variable 1	0.171	0.012	14.341	0.000	0.146	0.197	0.146	0.197

Mann-Whitney-Wilcoxon Test

n_1	16
n_2	16
Observed T	369.000
Expected T	264.000
Std. Dev. T	26.533
Test Statistic	3.957
p-Value (lower t	0.999962
p-Value (upper	0.000
p-Value (two ta	0.000
Reject H_0 , if p-Value < 0.05	
Significant Diff? Yes	
H_0 : Influent and Effluent Concentration is Same	
H_a : Influent and Effluent Concentration is Differ	

3~12 μm Solids Influent vs. Effluent Probability in 95% Confidence Interval

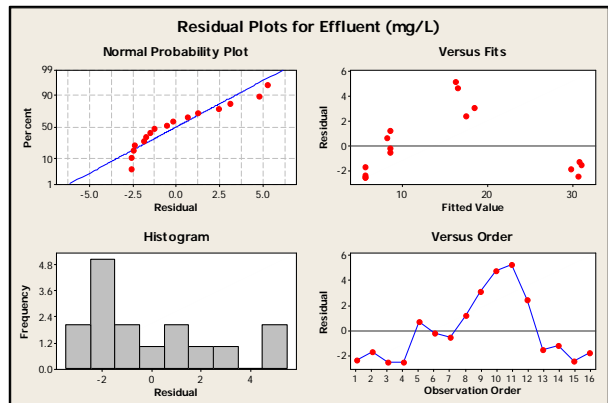
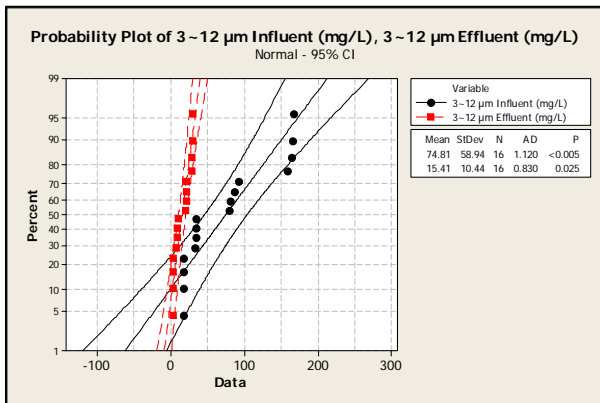
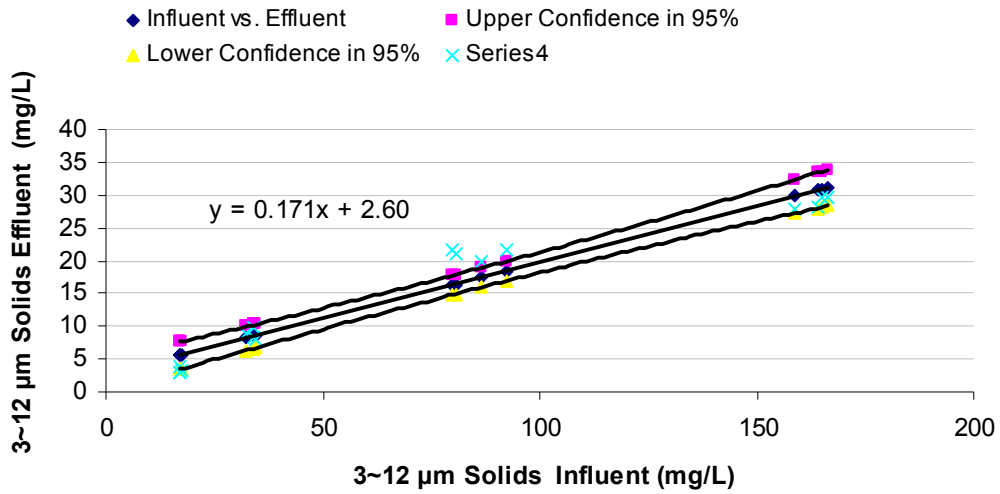

Appendix G.25: Sand Media 150gpm 12-30 μm Probability Analysis Detail

SUMMARY OUTPUT

<i>Regression Statistics</i>	
Multiple R	0.998
R Square	0.996
Adjusted R Square	0.929
Standard Error	1.726
Observations	16.000

ANOVA					
	<i>df</i>	<i>SS</i>	<i>MS</i>	<i>F</i>	<i>Significance F</i>
Regression	1.000	10657.362	10657.362	3578.481	0.000
Residual	15.000	44.673	2.978		
Total	16.000	10702.035			

	<i>Coefficients</i>	<i>Standard Error</i>	<i>t Stat</i>	<i>P-value</i>	<i>Lower 95%</i>	<i>Upper 95%</i>	<i>Lower 95.0%</i>	<i>Upper 95.0%</i>
Intercept	0.000	#N/A	#N/A	#N/A	#N/A	#N/A	#N/A	#N/A
X Variable 1	0.219	0.004	59.820	0.000	0.212	0.227	0.212	0.227

Mann-Whitney-Wilcoxon Test

n_1	16
n_2	16
Observed T	344.000
Expected T	264.000
Std. Dev. T	26.533
Test Statistic	3.015
p-Value (lower ta	0.998716
p-Value (upper ta	0.001
p-Value (two tail)	0.003
Reject H_0 , if p-Value < 0.05	
Significant Diff?	Yes
H_0 : Influent and Effluent Concentration is Same	
H_a : Influent and Effluent Concentration is Differ	

12~30 μm Solids Influent vs. Effluent Probability in 95% Confidence Interval

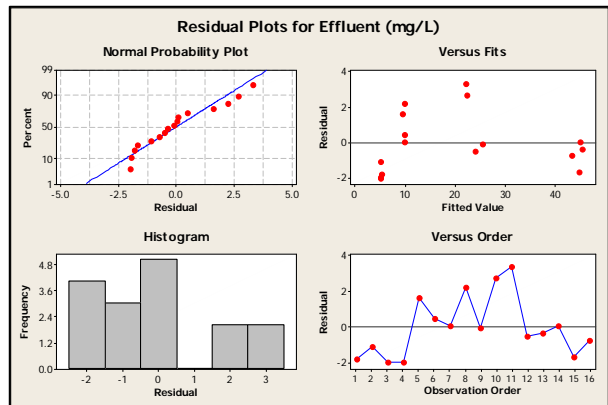
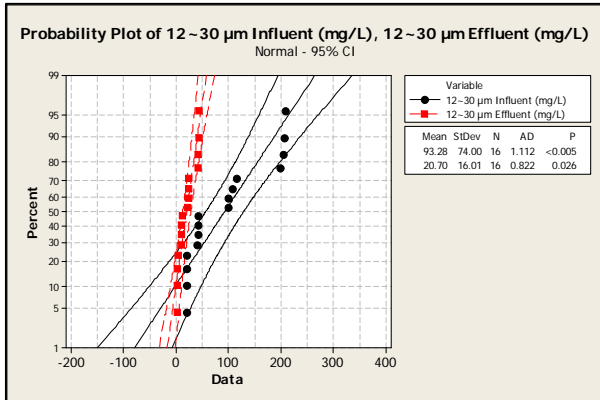
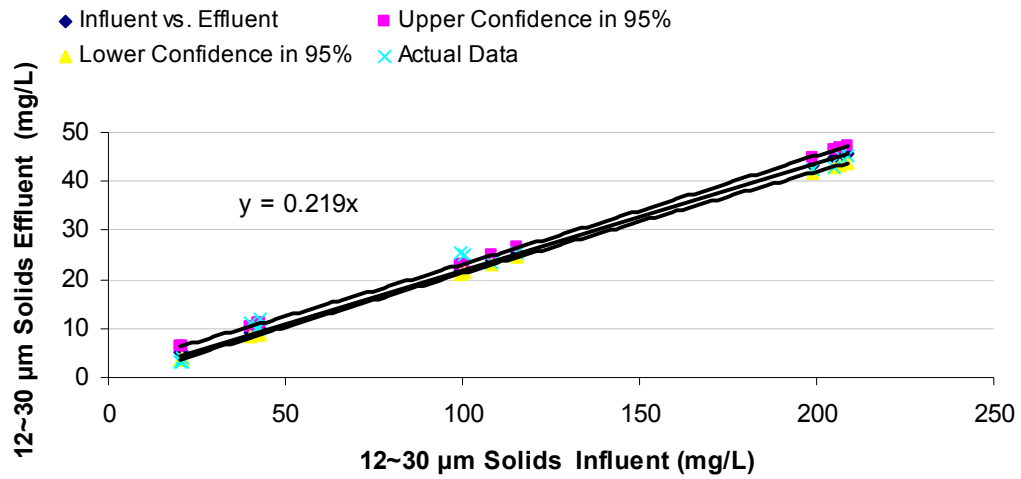

Appendix G.26: Sand Media 150gpm 30-60 μm Probability Analysis Detail

SUMMARY OUTPUT

<i>Regression Statistics</i>	
Multiple R	0.998
R Square	0.996
Adjusted R Square	0.930
Standard Error	0.922
Observations	16.000

ANOVA

	<i>df</i>	<i>SS</i>	<i>MS</i>	<i>F</i>	<i>Significance F</i>
Regression	1.000	3321.427	3321.427	3907.764	0.000
Residual	15.000	12.749	0.850		
Total	16.000	3334.176			

	<i>Coefficients</i>	<i>Standard Error</i>	<i>t Stat</i>	<i>P-value</i>	<i>Lower 95%</i>	<i>Upper 95%</i>	<i>Lower 95.0%</i>	<i>Upper 95.0%</i>
Intercept	0.000	#N/A	#N/A	#N/A	#N/A	#N/A	#N/A	#N/A
X Variable 1	0.233	0.004	62.512	0.000	0.225	0.241	0.225	0.241

Mann-Whitney-Wilcoxon Test

n_1	16
n_2	16
Observed T	344.000
Expected T	264.000
Std. Dev. T	26.533
Test Statistic	3.015
p-Value (lower t	0.998716
p-Value (upper	0.001
p-Value (two ta	0.003
Reject H_0 , if p-Value < 0.05	
Significant Diff? Yes	
H_0 : Influent and Effluent Concentration is Same	
H_a : Influent and Effluent Concentration is Differ	

30~60 µm Solids Influent vs. Effluent Probability in 95% Confidence Interval

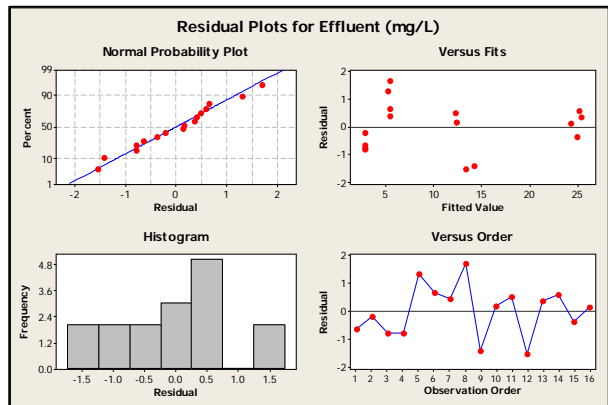
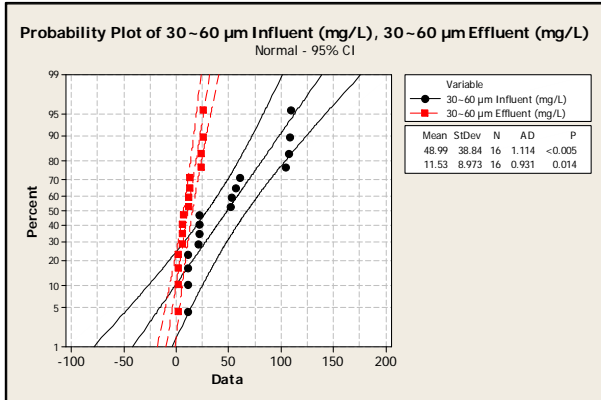
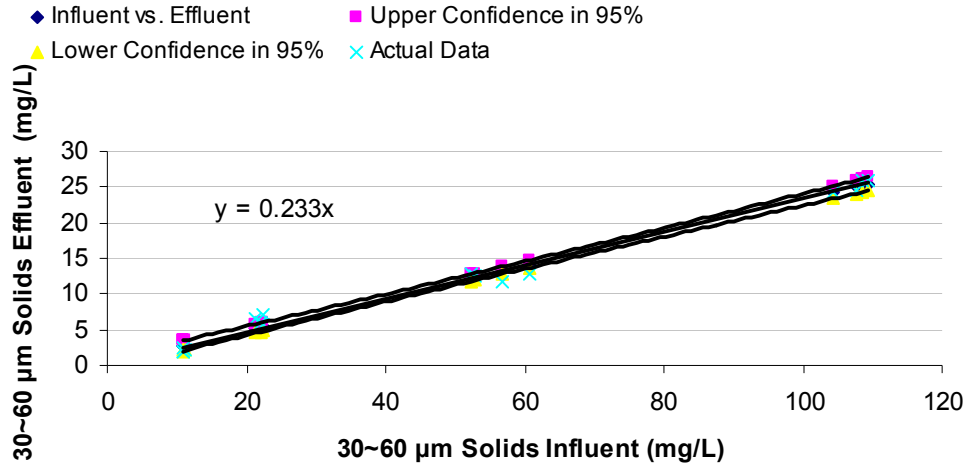

Appendix G.27: Sand Media 150gpm 60-120 μm Probability Analysis Detail

SUMMARY OUTPUT

<i>Regression Statistics</i>	
Multiple R	0.920
R Square	0.846
Adjusted R Square	0.835
Standard Error	0.312
Observations	16.000

ANOVA					
	<i>df</i>	<i>SS</i>	<i>MS</i>	<i>F</i>	<i>Significance F</i>
Regression	1.000	7.473	7.473	76.736	0.000
Residual	14.000	1.363	0.097		
Total	15.000	8.836			

	<i>Coefficients</i>	<i>Standard Error</i>	<i>t Stat</i>	<i>P-value</i>	<i>Lower 95%</i>	<i>Upper 95%</i>	<i>Lower 95.0%</i>	<i>Upper 95.0%</i>
Intercept	0.698	0.129	5.401	0.000	0.421	0.975	0.421	0.975
X Variable 1	0.151	0.017	8.760	0.000	0.114	0.188	0.114	0.188

Mann-Whitney-Wilcoxon Test

n_1	16
n_2	16
Observed T	359.000
Expected T	264.000
Std. Dev. T	26.533
Test Statistic	3.580
p-Value (lower tail)	0.999828
p-Value (upper tail)	0.000
p-Value (two-tailed)	0.000
Reject H_0 , if p-Value < 0.05	
Significant Diff? Yes	
H_0 : Influent and Effluent Concentration is Same	
H_a : Influent and Effluent Concentration is Differ	

60~120 µm Solids Influent vs. Effluent Probability in 95% Confidence Interval

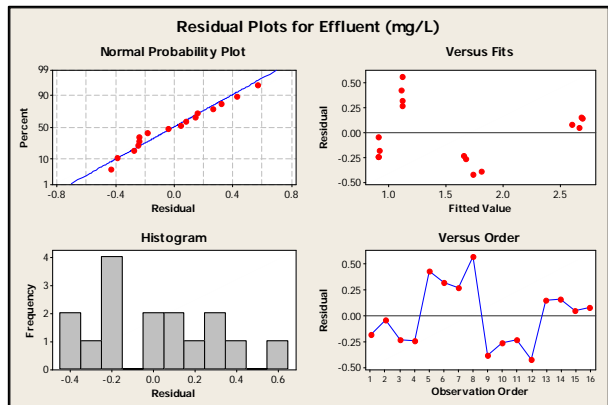
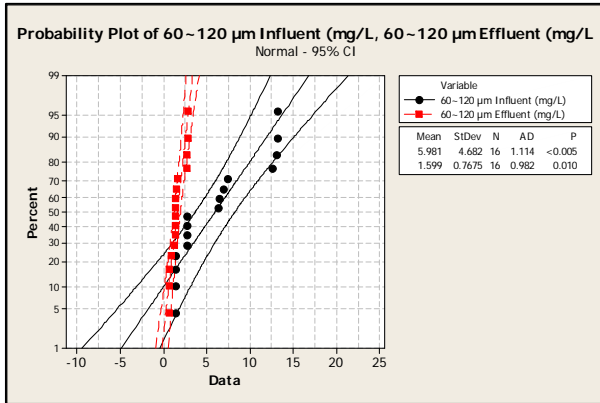
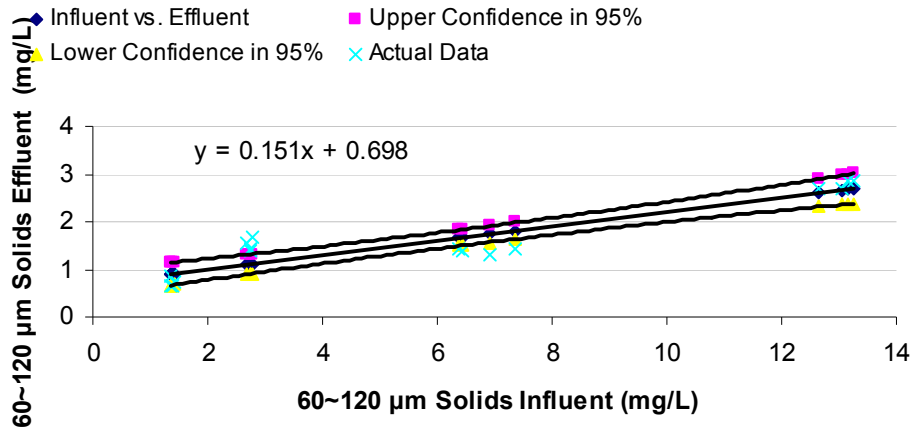

Appendix G.28: Sand Media 150gpm 120-250 μ m Probability Analysis Detail

SUMMARY OUTPUT

<i>Regression Statistics</i>	
Multiple R	0.223
R Square	0.050
Adjusted R Square	-0.018
Standard Error	0.668
Observations	16.000

ANOVA					
	<i>df</i>	<i>SS</i>	<i>MS</i>	<i>F</i>	<i>Significance F</i>
Regression	1.000	0.327	0.327	0.733	0.406
Residual	14.000	6.240	0.446		
Total	15.000	6.567			

	<i>Coefficients</i>	<i>Standard Error</i>	<i>t Stat</i>	<i>P-value</i>	<i>Lower 95%</i>	<i>Upper 95%</i>	<i>Lower 95.0%</i>	<i>Upper 95.0%</i>
Intercept	0.546	0.275	1.987	0.067	-0.043	1.134	-0.043	1.134
X Variable 1	0.082	0.096	0.856	0.406	-0.123	0.287	-0.123	0.287

Mann-Whitney-Wilcoxon Test

n_1	16
n_2	16
Observed T	392.000
Expected T	264.000
Std. Dev. T	26.533
Test Statistic	4.824
p-Value (lower)	0.999999
p-Value (upper)	0.000
p-Value (two ta	0.000

Reject H_0 , if p-Value < 0.05

Significant Diff? Yes

H_0 : Influent and Effluent Concentration is Same
 H_a : Influent and Effluent Concentration is Differ

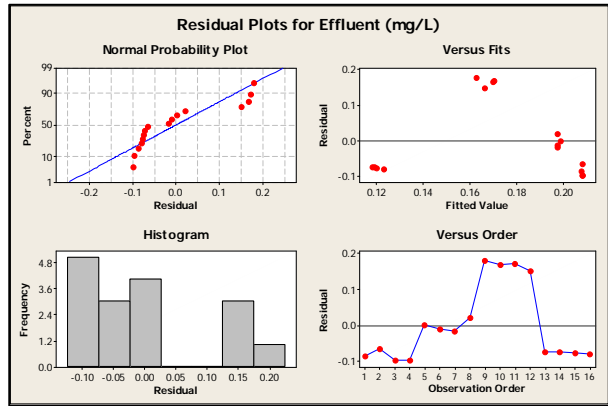
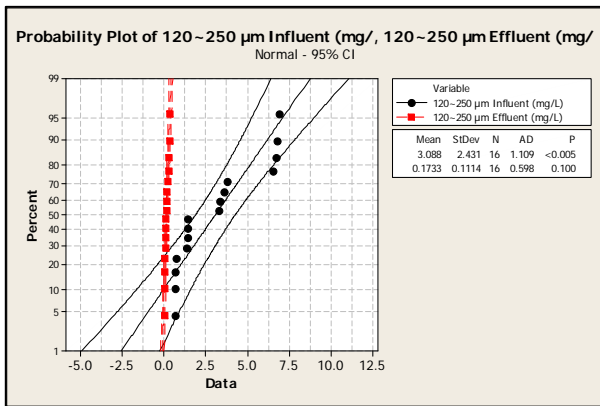
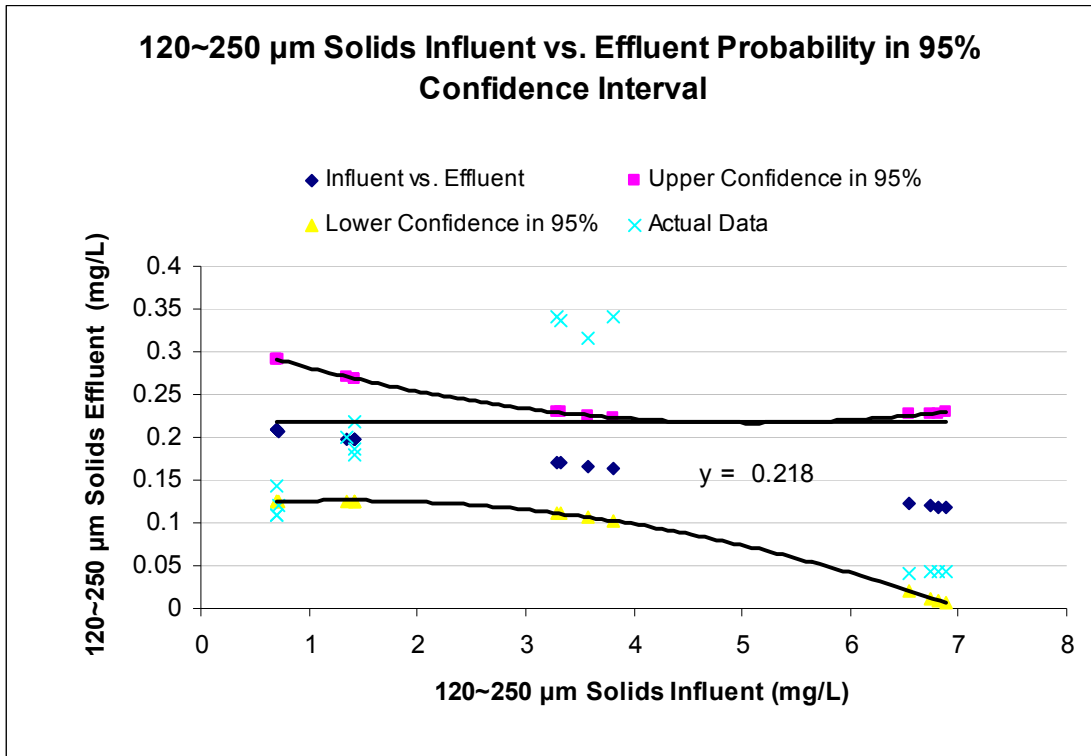

Appendix G.29: Sand Media 150gpm 250-1180 μm Probability Analysis Detail

SUMMARY OUTPUT

<i>Regression Statistics</i>	
Multiple R	1
R Square	1
Adjusted R Square	1
Standard Error	0
Observations	16

ANOVA

	<i>df</i>	<i>SS</i>	<i>MS</i>	<i>F</i>	<i>Significance F</i>
Regression	1	0	0	#NUM!	#NUM!
Residual	14	0	0		
Total	15	0			

	<i>Coefficients</i>	<i>Standard Error</i>	<i>t Stat</i>	<i>P-value</i>	<i>Lower 95%</i>	<i>Upper 95%</i>	<i>Lower 90.0%</i>	<i>Upper 90.0%</i>
Intercept	0	0	65535	#NUM!	0	0	0	0
X Variable 1	0	0	65535	#NUM!	0	0	0	0

Mann-Whitney-Wilcoxon Test

n_1	16
n_2	16
Observed T	392.000
Expected T	264.000
Std. Dev. T	26.533
Test Statistic	4.824
p-Value (lower tail)	0.999999
p-Value (upper tail)	0.000
p-Value (two-tailed)	0.000
Reject H_0 , if p-Value < 0.05	
Significant Diff? Yes	
H_0 : Influent and Effluent Concentration is Same	
H_a : Influent and Effluent Concentration is Differ	

250~1180 μm Solids Influent vs. Effluent Probability in 95% Confidence Interval

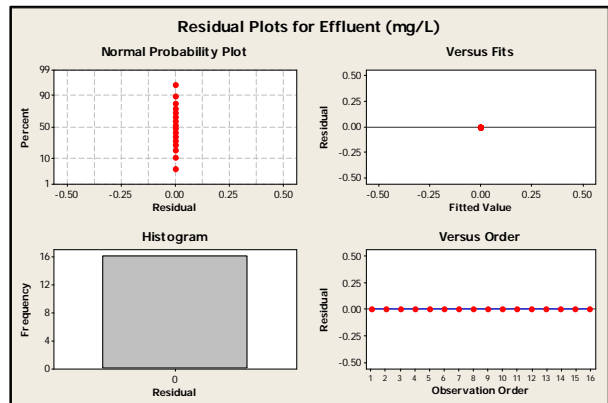
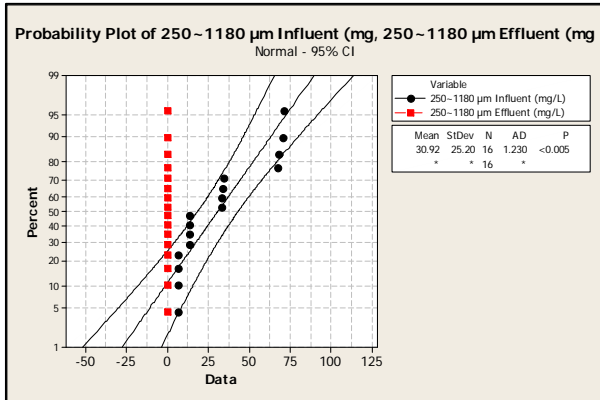
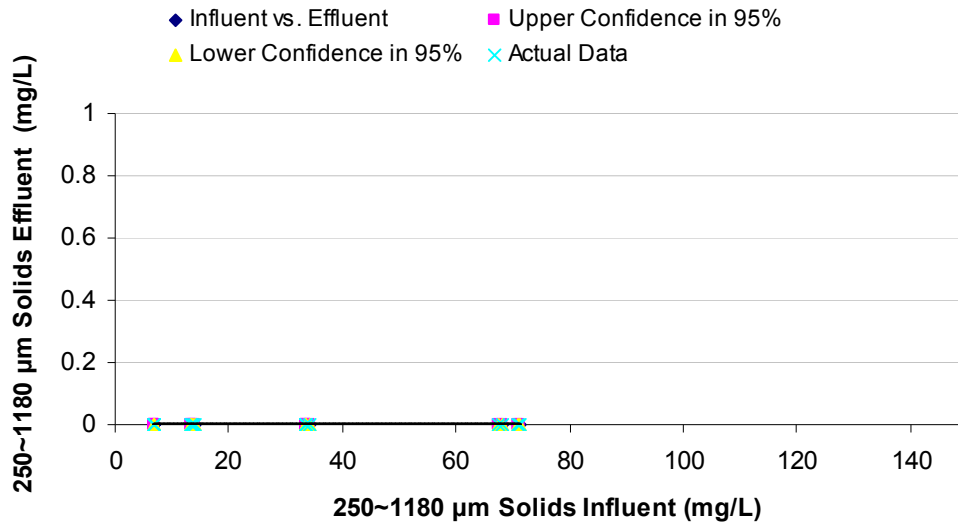

Appendix G.30: Sand Media 150gpm >1180 µm Probability Analysis Detail

SUMMARY OUTPUT

Regression Statistics	
Multiple R	1
R Square	1
Adjusted R Square	1
Standard Error	0
Observations	16

ANOVA

	df	SS	MS	F	Significance F
Regression	1	0	0	#NUM!	#NUM!
Residual	14	0	0		
Total	15	0			

	Coefficients	Standard Error	t Stat	P-value	Lower 95%	Upper 95%	Lower 90.0%	Upper 90.0%
Intercept	0	0	65535	#NUM!	0	0	0	0
X Variable 1	0	0	65535	#NUM!	0	0	0	0

Mann-Whitney-Wilcoxon Test

n ₁	16
n ₂	16
Observed T	392.000
Expected T	264.000
Std. Dev. T	26.533
Test Statistic	4.824
p-Value (lower tail)	0.999999
p-Value (upper tail)	0.000
p-Value (two-tailed)	0.000
Reject H ₀ , if p-Value < 0.05	
Significant Diff? Yes	
H ₀ : Influent and Effluent Concentration is Same	
H _a : Influent and Effluent Concentration is Differ	

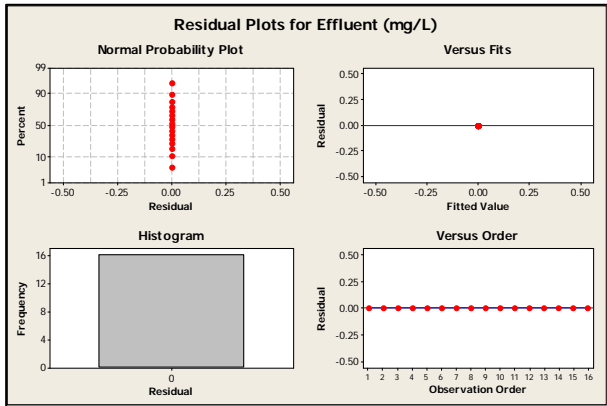
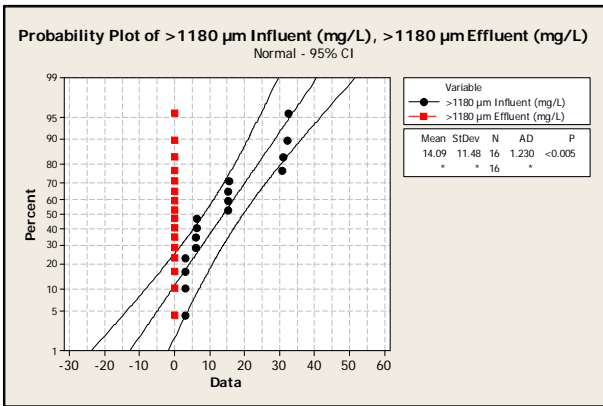
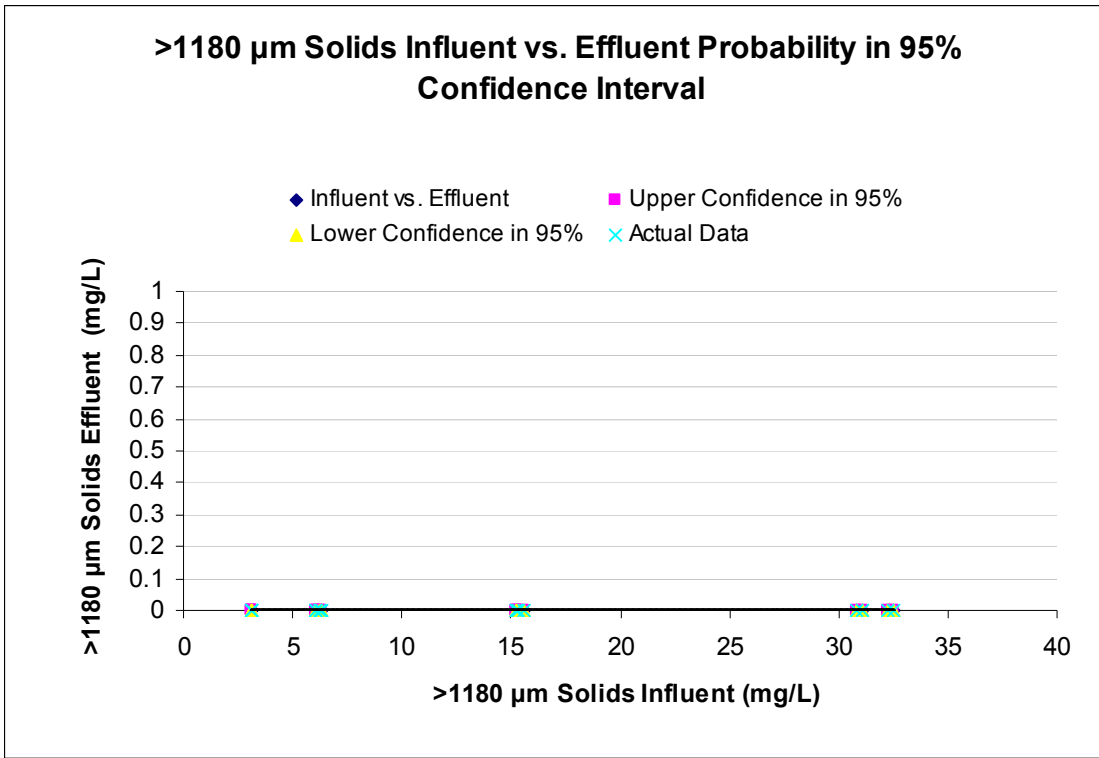

Appendix G.31: Mixed Media 25gpm TSS Probability Analysis Detail

SUMMARY OUTPUT

<i>Regression Statistics</i>	
Multiple R	0.904
R Square	0.818
Adjusted R Square	0.805
Standard Error	6.543
Observations	16.000

ANOVA					
	<i>df</i>	<i>SS</i>	<i>MS</i>	<i>F</i>	<i>Significance F</i>
Regression	1.000	2686.115	2686.115	62.747	0.000
Residual	14.000	599.322	42.809		
Total	15.000	3285.438			

	<i>Coefficients</i>	<i>Standard Error</i>	<i>t Stat</i>	<i>P-value</i>	<i>Lower 95%</i>	<i>Upper 95%</i>	<i>Lower 95.0%</i>	<i>Upper 95.0%</i>
Intercept	14.056	2.698	5.210	0.000	8.270	19.843	8.270	19.843
X Variable 1	0.094	0.012	7.921	0.000	0.069	0.120	0.069	0.120

Mann-Whitney-Wilcoxon Test

n_1	16
n_2	16
Observed T	376.000
Expected T	264.000
Std. Dev. T	26.533
Test Statistic	4.221
p-Value (lower tail)	0.999988
p-Value (upper tail)	0.000
p-Value (two tail)	0.000 Reject H_0 , if p-Value < 0.05
Significant Diff?	Yes
H_0 : Influent and Effluent Concentration is Same	
H_a : Influent and Effluent Concentration is Differ	

TSS Influent vs. Effluent Probability in 95% Confidence Interval

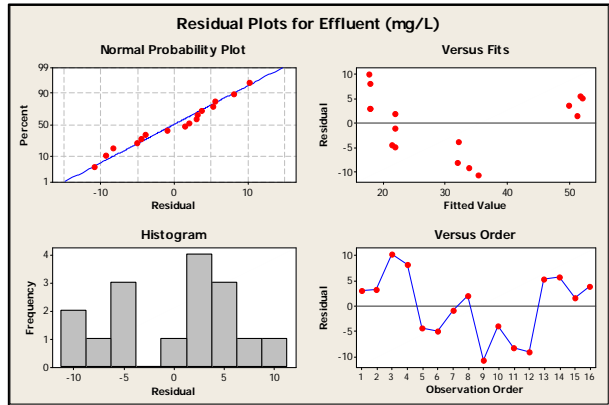
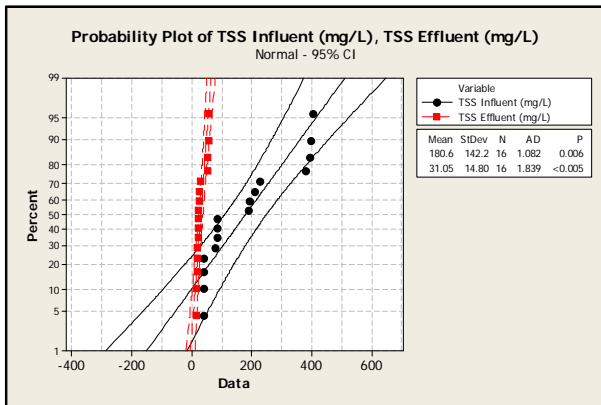
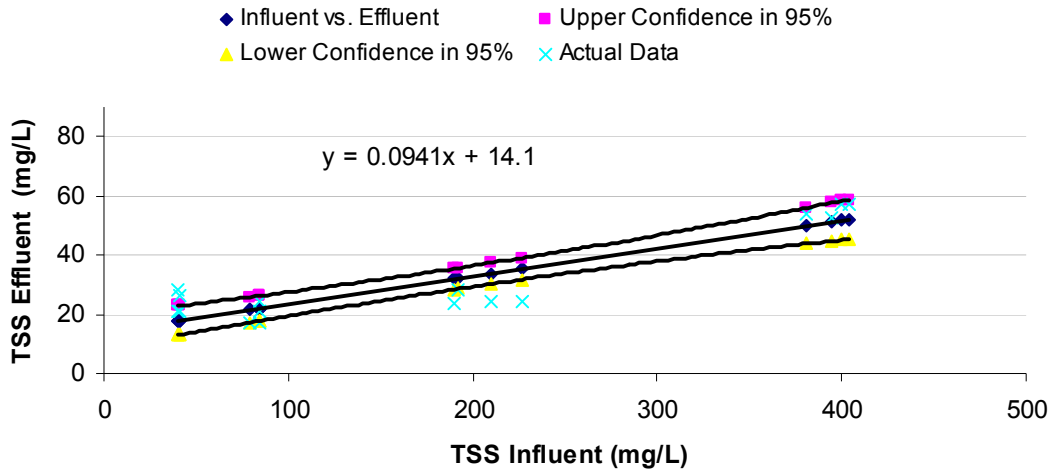

Appendix G.32: Mixed Media 25gpm TDS Probability Analysis Detail

SUMMARY OUTPUT

<i>Regression Statistics</i>	
Multiple R	0.759
R Square	0.576
Adjusted R Square	0.546
Standard Error	11.185
Observations	16.000

ANOVA					
	<i>df</i>	<i>SS</i>	<i>MS</i>	<i>F</i>	<i>Significance F</i>
Regression	1.000	2377.826	2377.826	19.005	0.001
Residual	14.000	1751.611	125.115		
Total	15.000	4129.437			

	<i>Coefficients</i>	<i>Standard Error</i>	<i>t Stat</i>	<i>P-value</i>	<i>Lower 95%</i>	<i>Upper 95%</i>	<i>Lower 95.0%</i>	<i>Upper 95.0%</i>
Intercept	-103.012	45.435	-2.267	0.040	-200.461	-5.563	-200.461	-5.563
X Variable 1	1.406	0.323	4.359	0.001	0.714	2.098	0.714	2.098

Mann-Whitney-Wilcoxon Test

n_1	16
n_2	16
Observed T	392.000
Expected T	264.000
Std. Dev. T	26.533
Test Statistic	4.824
p-Value (lower t	0.999999
p-Value (upper	0.000
p-Value (two ta	0.000
Reject H_0 , if p-Value < 0.05	
Significant Diff? Yes	
H_0 : Influent and Effluent Concentration is Same	
H_a : Influent and Effluent Concentration is Differ	

TDS Influent vs. Effluent Probability in 95% Confidence Interval

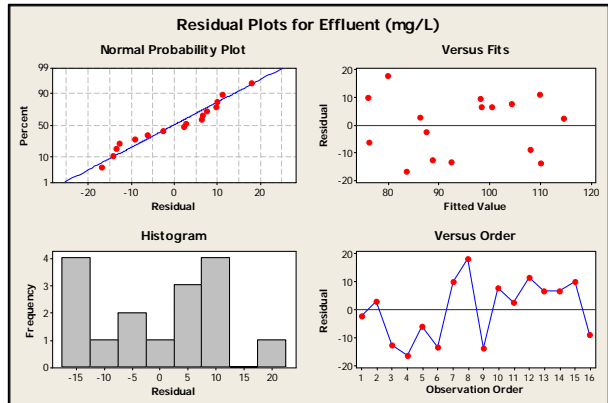
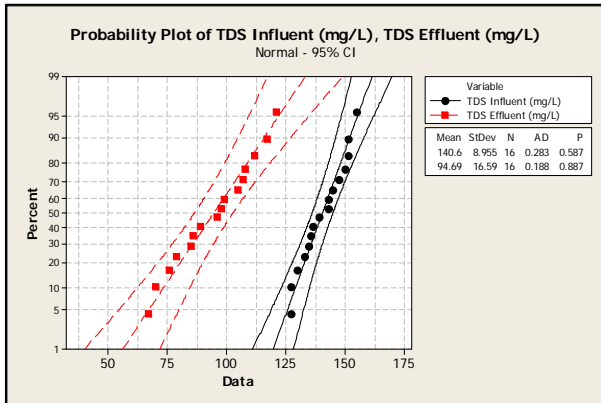
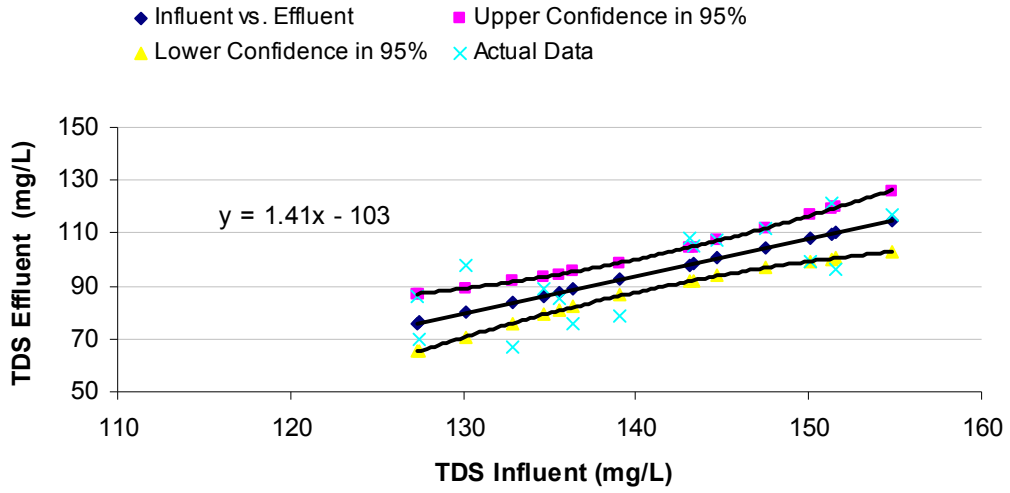

Appendix G.33: Mixed Media 25gpm 0.45-3 μm Probability Analysis Detail

SUMMARY OUTPUT

<i>Regression Statistics</i>	
Multiple R	0.958
R Square	0.918
Adjusted R Square	0.912
Standard Error	0.595
Observations	16.000

ANOVA

	<i>df</i>	<i>SS</i>	<i>MS</i>	<i>F</i>	<i>Significance F</i>
Regression	1.000	55.673	55.673	157.127	0.000
Residual	14.000	4.960	0.354		
Total	15.000	60.633			

	<i>Coefficients</i>	<i>Standard Error</i>	<i>t Stat</i>	<i>P-value</i>	<i>Lower 95%</i>	<i>Upper 95%</i>	<i>Lower 95.0%</i>	<i>Upper 95.0%</i>
Intercept	0.604	0.248	2.437	0.029	0.072	1.136	0.072	1.136
X Variable 1	0.200	0.016	12.535	0.000	0.166	0.234	0.166	0.234

Mann-Whitney-Wilcoxon Test

n_1	16
n_2	16
Observed T	347.000
Expected T	264.000
Std. Dev. T	26.533
Test Statistic	3.128
p-Value (lower tail)	0.999121
p-Value (upper tail)	0.001
p-Value (two-tailed)	0.002
Reject H_0 , if p-Value < 0.05	
Significant Diff? Yes	
H_0 : Influent and Effluent Concentration is Same	
H_a : Influent and Effluent Concentration is Differ	

0.45~3 μm Solids Influent vs. Effluent Probability in 95% Confidence Interval

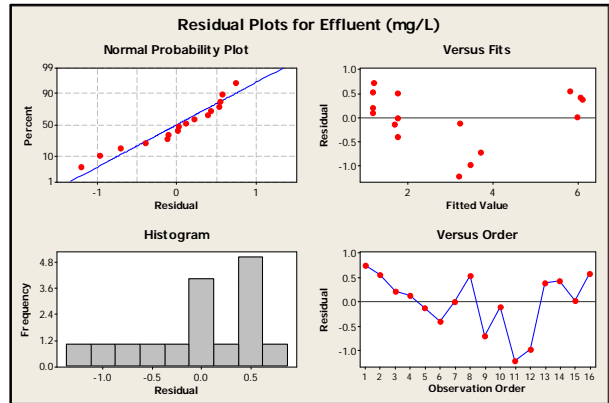
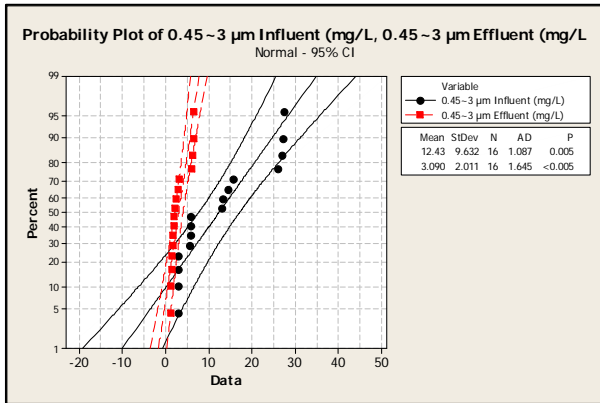
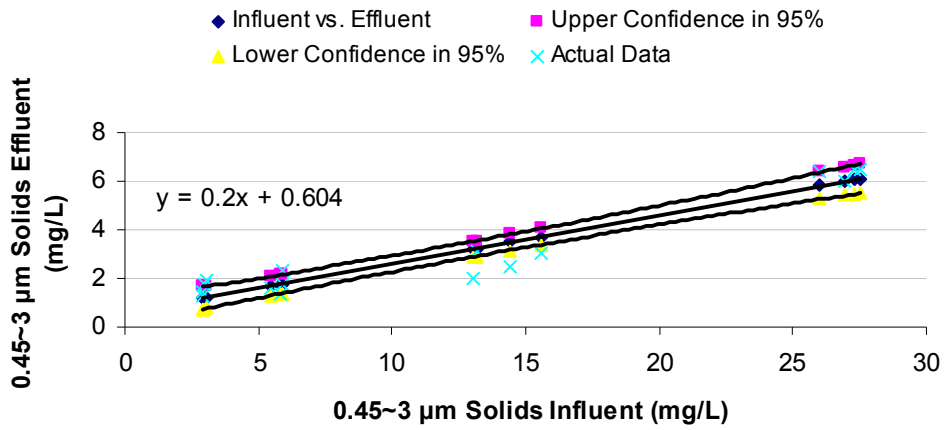

Appendix G.34: Mixed Media 25gpm 3-12 μ m Probability Analysis Detail

SUMMARY OUTPUT

<i>Regression Statistics</i>	
Multiple R	0.955
R Square	0.912
Adjusted R Square	0.905
Standard Error	2.266
Observations	16.000

ANOVA					
	<i>df</i>	<i>SS</i>	<i>MS</i>	<i>F</i>	<i>Significance F</i>
Regression	1.000	742.214	742.214	144.538	0.000
Residual	14.000	71.891	5.135		
Total	15.000	814.105			

	<i>Coefficients</i>	<i>Standard Error</i>	<i>t Stat</i>	<i>P-value</i>	<i>Lower 95%</i>	<i>Upper 95%</i>	<i>Lower 95.0%</i>	<i>Upper 95.0%</i>
Intercept	4.180	0.938	4.455	0.001	2.168	6.192	2.168	6.192
X Variable 1	0.191	0.016	12.022	0.000	0.157	0.225	0.157	0.225

Mann-Whitney-Wilcoxon Test

n_1	16
n_2	16
Observed T	344.000
Expected T	264.000
Std. Dev. T	26.533
Test Statistic	3.015
p-Value (lower)	0.998716
p-Value (upper)	0.001
p-Value (two ta	0.003
Reject H_0 , if p-Value < 0.05	
Significant Diff? Yes	
H_0 : Influent and Effluent Concentration is Same	
H_a : Influent and Effluent Concentration is Differ	

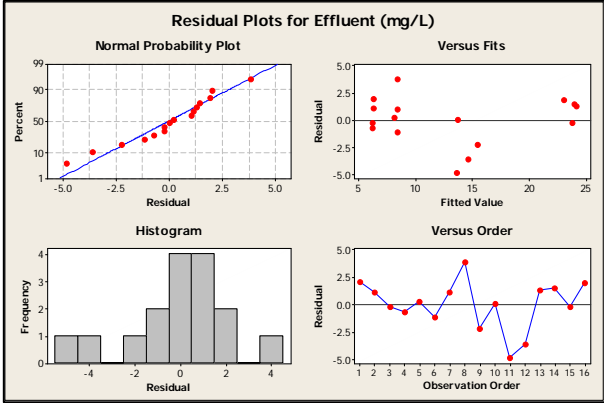
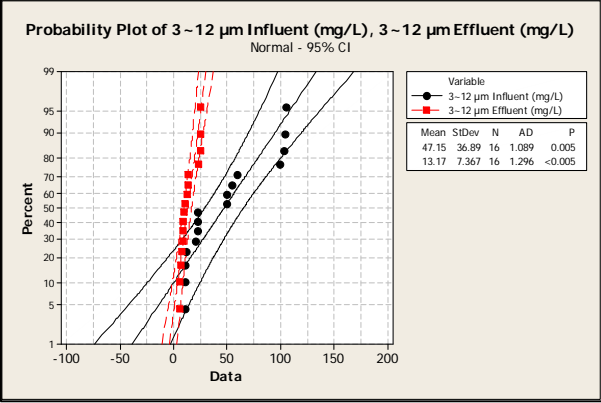
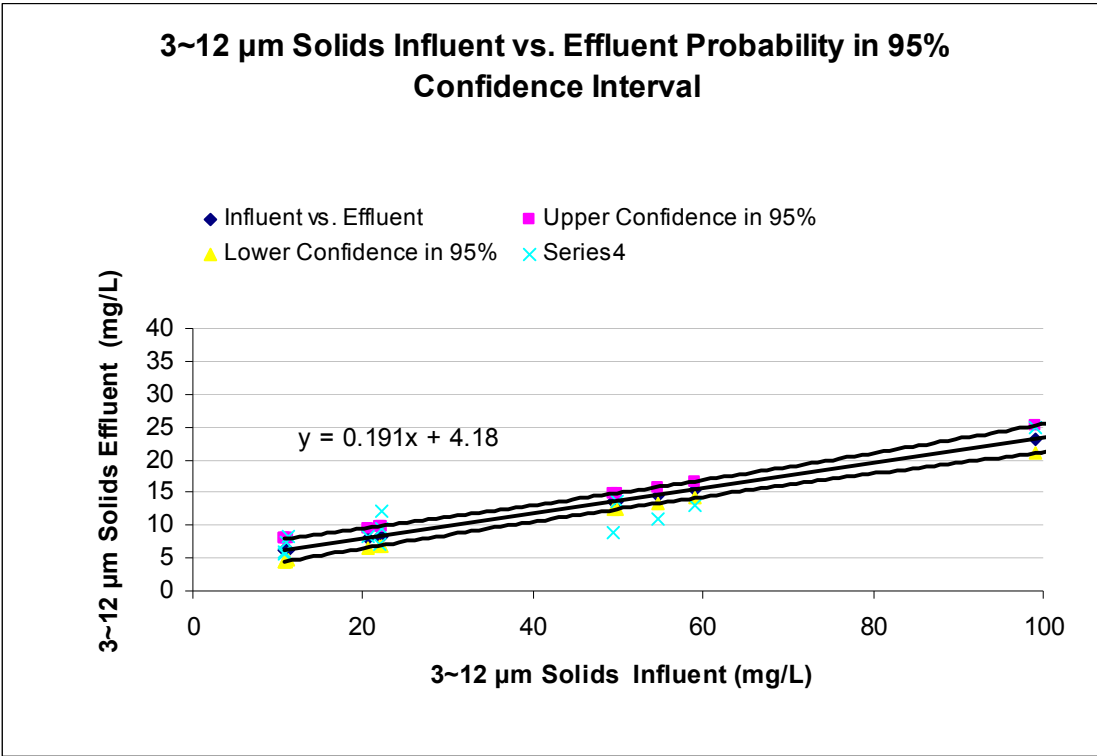

Appendix G.35: Mixed Media 25gpm 12-30 μm Probability Analysis Detail

SUMMARY OUTPUT

<i>Regression Statistics</i>	
Multiple R	0.976
R Square	0.952
Adjusted R Square	0.885
Standard Error	1.986
Observations	16.000

ANOVA					
	<i>df</i>	<i>SS</i>	<i>MS</i>	<i>F</i>	<i>Significance F</i>
Regression	1.000	1169.615	1169.615	296.688	0.000
Residual	15.000	59.134	3.942		
Total	16.000	1228.749			

	<i>Coefficients</i>	<i>Standard Error</i>	<i>t Stat</i>	<i>P-value</i>	<i>Lower 95%</i>	<i>Upper 95%</i>	<i>Lower 95.0%</i>	<i>Upper 95.0%</i>
Intercept	0.000	#N/A	#N/A	#N/A	#N/A	#N/A	#N/A	#N/A
X Variable 1	0.116	0.007	17.225	0.000	0.102	0.131	0.102	0.131

Mann-Whitney-Wilcoxon Test

n_1	16
n_2	16
Observed T	376.000
Expected T	264.000
Std. Dev. T	26.533
Test Statistic	4.221
p-Value (lower t	0.999988
p-Value (upper	0.000
p-Value (two ta	0.000
Reject H_0 , if p-Value < 0.05	
Significant Diff? Yes	
H_0 : Influent and Effluent Concentration is Same	
H_a : Influent and Effluent Concentration is Differ	

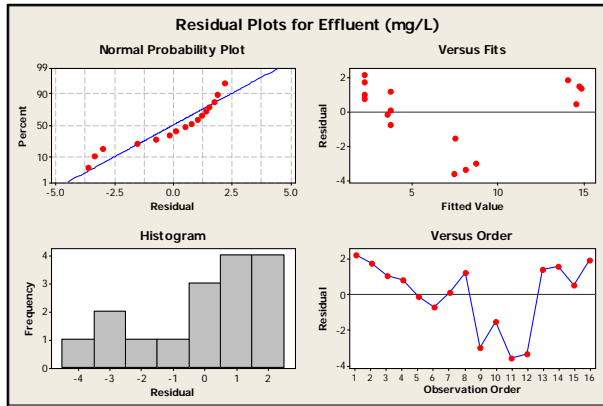
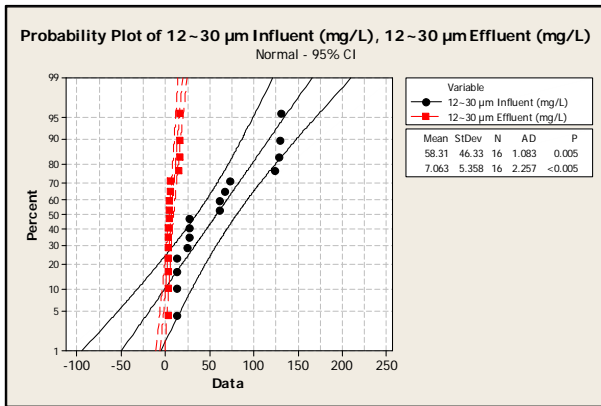
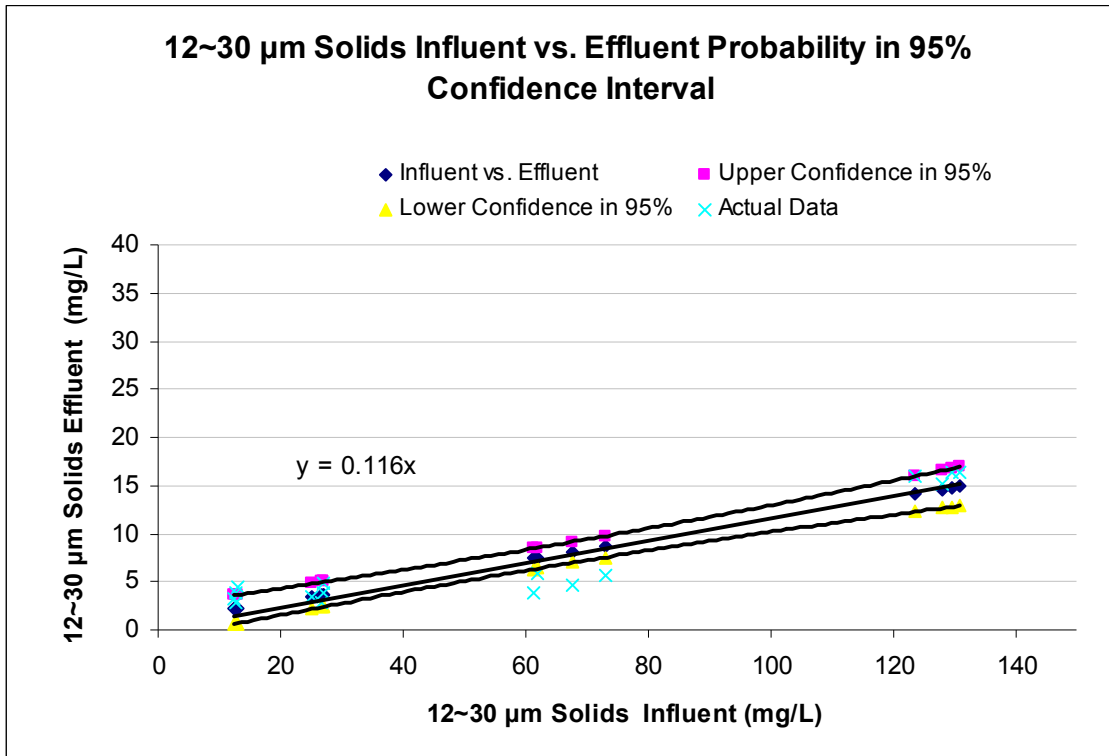

Appendix G.36: Mixed Media 25gpm 30-60 μm Probability Analysis Detail

SUMMARY OUTPUT

<i>Regression Statistics</i>	
Multiple R	0.809
R Square	0.655
Adjusted R Square	0.630
Standard Error	0.848
Observations	16.000

ANOVA

	<i>df</i>	<i>SS</i>	<i>MS</i>	<i>F</i>	<i>Significance F</i>
Regression	1.000	19.123	19.123	26.589	0.000
Residual	14.000	10.069	0.719		
Total	15.000	29.192			

	<i>Coefficients</i>	<i>Standard Error</i>	<i>t Stat</i>	<i>P-value</i>	<i>Lower 95%</i>	<i>Upper 95%</i>	<i>Lower 95.0%</i>	<i>Upper 95.0%</i>
Intercept	1.079	0.348	3.100	0.008	0.332	1.825	0.332	1.825
X Variable 1	0.046	0.009	5.156	0.000	0.027	0.066	0.027	0.066

Mann-Whitney-Wilcoxon Test

n_1	16
n_2	16
Observed T	392.000
Expected T	264.000
Std. Dev. T	26.533
Test Statistic	4.824
p-Value (lower)	0.999999
p-Value (upper)	0.000
p-Value (two ta	0.000
Reject H_0 , if p-Value < 0.05	
Significant Diff? Yes	
H_0 : Influent and Effluent Concentration is Same	
H_a : Influent and Effluent Concentration is Differ	

30~60 μm Solids Influent vs. Effluent Probability in 95% Confidence Interval

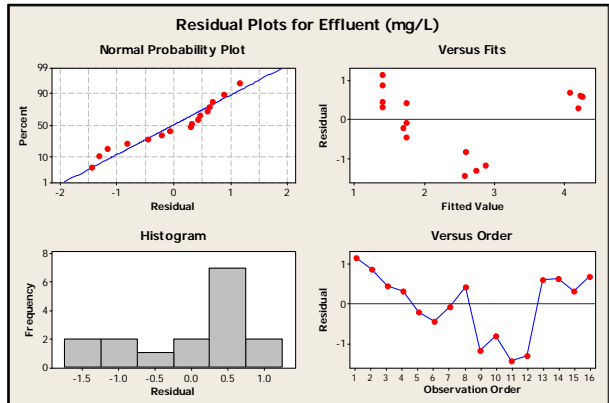
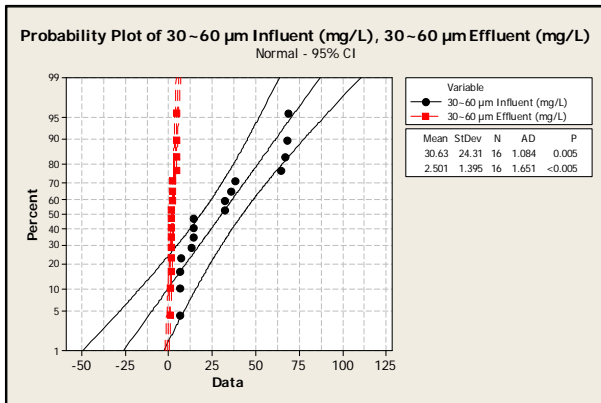
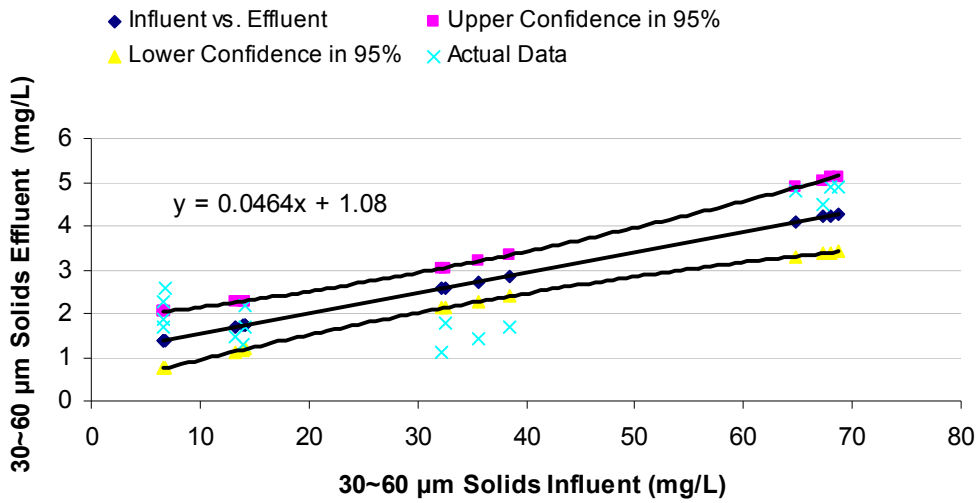

Appendix G.37: Mixed Media 25gpm 60-120 μ m Probability Analysis Detail

SUMMARY OUTPUT

<i>Regression Statistics</i>	
Multiple R	0.575
R Square	0.330
Adjusted R Square	0.283
Standard Error	0.211
Observations	16.000

ANOVA						
	<i>df</i>	<i>SS</i>	<i>MS</i>	<i>F</i>	<i>Significance F</i>	
Regression	1.000	0.309	0.309	6.910	0.020	
Residual	14.000	0.626	0.045			
Total	15.000	0.935				

	<i>Coefficients</i>	<i>Standard Error</i>	<i>t Stat</i>	<i>P-value</i>	<i>Lower 95%</i>	<i>Upper 95%</i>	<i>Lower 95.0%</i>	<i>Upper 95.0%</i>
Intercept	0.292	0.088	3.334	0.005	0.104	0.480	0.104	0.480
X Variable 1	0.049	0.019	2.629	0.020	0.009	0.089	0.009	0.089

Mann-Whitney-Wilcoxon Test

n_1	16
n_2	16
Observed T	392.000
Expected T	264.000
Std. Dev. T	26.533
Test Statistic	4.824
p-Value (lower tail)	0.999999
p-Value (upper tail)	0.000
p-Value (two-tailed)	0.000
Reject H_0 , if p-Value < 0.05	
Significant Diff? Yes	
H_0 : Influent and Effluent Concentration is Same	
H_a : Influent and Effluent Concentration is Differ	

60~120 µm Solids Influent vs. Effluent Probability in 95% Confidence Interval

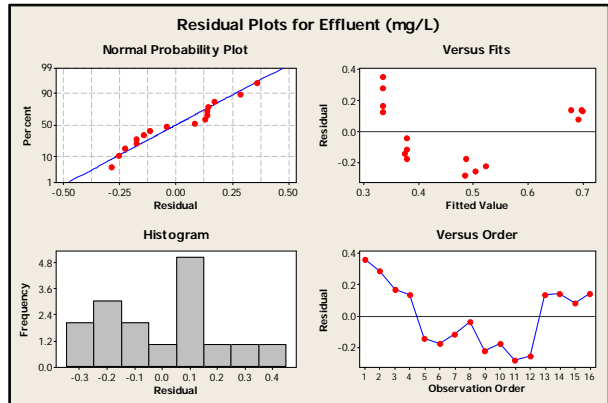
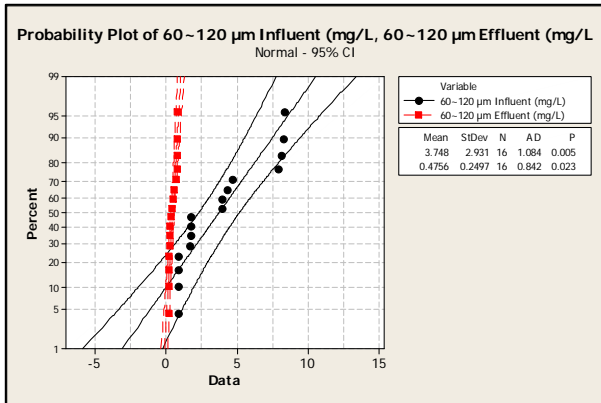
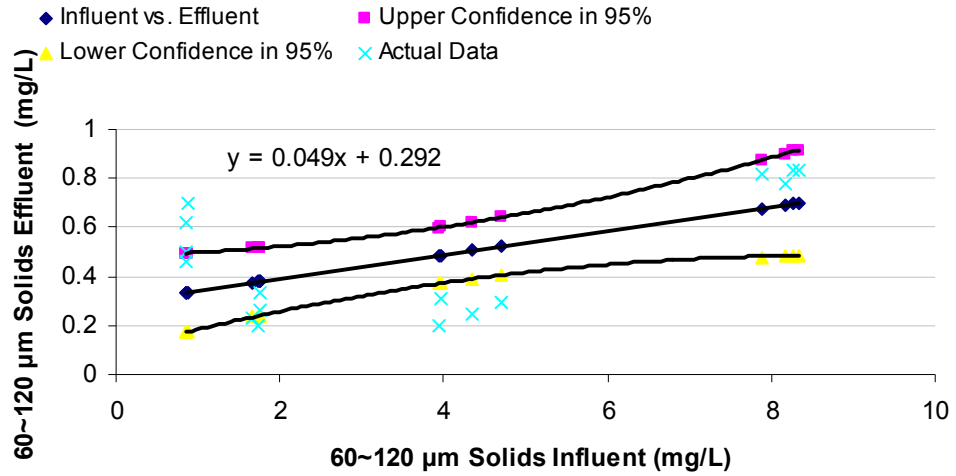

Appendix G.38: Mixed Media 25gpm 120-250 μ m Probability Analysis Detail

SUMMARY OUTPUT

<i>Regression Statistics</i>	
Multiple R	0.079
R Square	0.006
Adjusted R Square	-0.065
Standard Error	0.050
Observations	16.000

ANOVA						
	<i>df</i>	<i>SS</i>	<i>MS</i>	<i>F</i>	<i>Significance F</i>	
Regression	1.000	0.000	0.000	0.088	0.772	
Residual	14.000	0.035	0.002			
Total	15.000	0.035				

	<i>Coefficients</i>	<i>Standard Error</i>	<i>t Stat</i>	<i>P-value</i>	<i>Lower 95%</i>	<i>Upper 95%</i>	<i>Lower 95.0%</i>	<i>Upper 95.0%</i>
Intercept	0.082	0.020	4.006	0.001	0.038	0.125	0.038	0.125
X Variable 1	-0.003	0.008	-0.296	0.772	-0.021	0.016	-0.021	0.016

Mann-Whitney-Wilcoxon Test

n_1	16
n_2	16
Observed T	392.000
Expected T	264.000
Std. Dev. T	26.533
Test Statistic	4.824
p-Value (lower	0.999999
p-Value (upper	0.000
p-Value (two ta	0.000
Reject H_0 , if p-Value < 0.05	
Significant Diff? Yes	
H_0 : Influent and Effluent Concentration is Same	
H_a : Influent and Effluent Concentration is Differ	

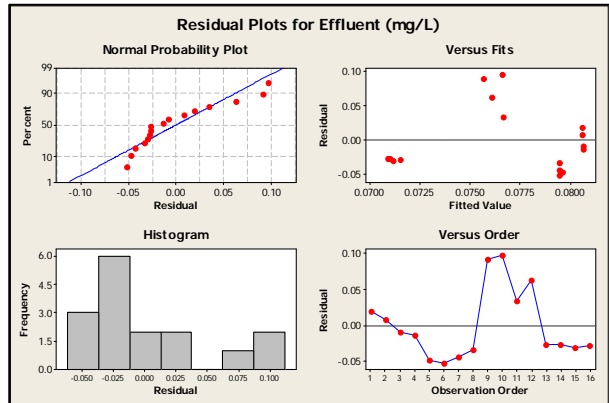
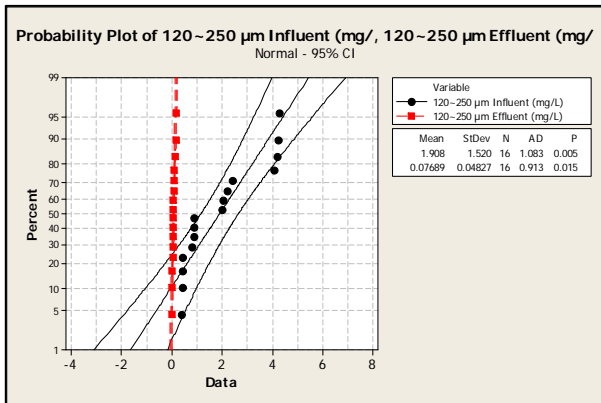
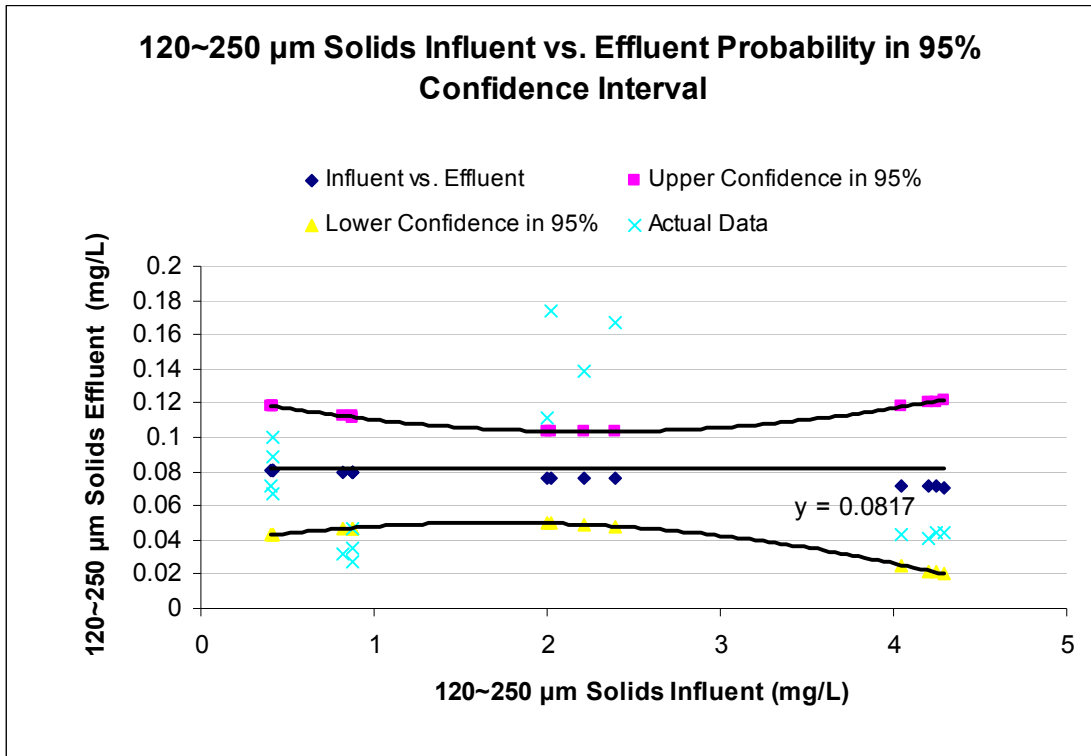

Appendix G.39: Mixed Media 25gpm 250-1180 μm Probability Analysis Detail

SUMMARY OUTPUT

<i>Regression Statistics</i>	
Multiple R	1
R Square	1
Adjusted R Square	1
Standard Error	0
Observations	16

ANOVA					
	<i>df</i>	<i>SS</i>	<i>MS</i>	<i>F</i>	<i>Significance F</i>
Regression	1	0	0	#NUM!	#NUM!
Residual	14	0	0		
Total	15	0			

	<i>Coefficients</i>	<i>Standard Error</i>	<i>t Stat</i>	<i>P-value</i>	<i>Lower 95%</i>	<i>Upper 95%</i>	<i>Lower 90.0%</i>	<i>Upper 90.0%</i>
Intercept	0	0	65535	#NUM!	0	0	0	0
X Variable 1	0	0	65535	#NUM!	0	0	0	0

Mann-Whitney-Wilcoxon Test

n_1	16
n_2	16
Observed T	392.000
Expected T	264.000
Std. Dev. T	26.533
Test Statistic	4.824
p-Value (lower tail)	0.999999
p-Value (upper tail)	0.000
p-Value (two-tailed)	0.000
Reject H_0 , if p-Value < 0.05	
Significant Diff? Yes	
H_0 : Influent and Effluent Concentration is Same	
H_a : Influent and Effluent Concentration is Differ	

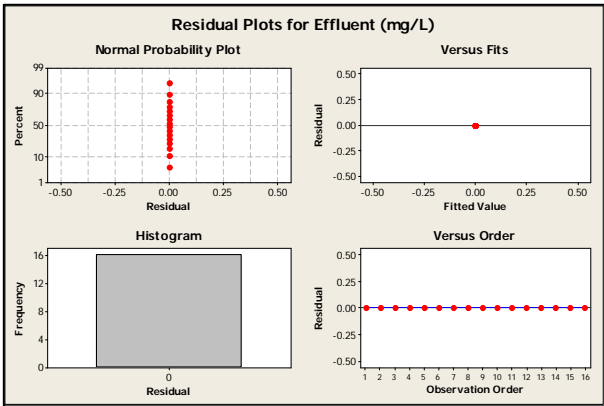
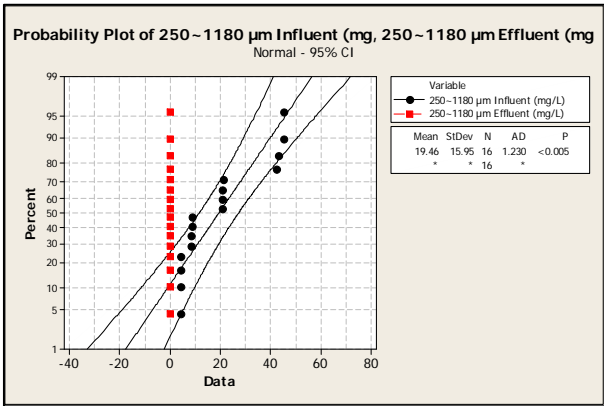
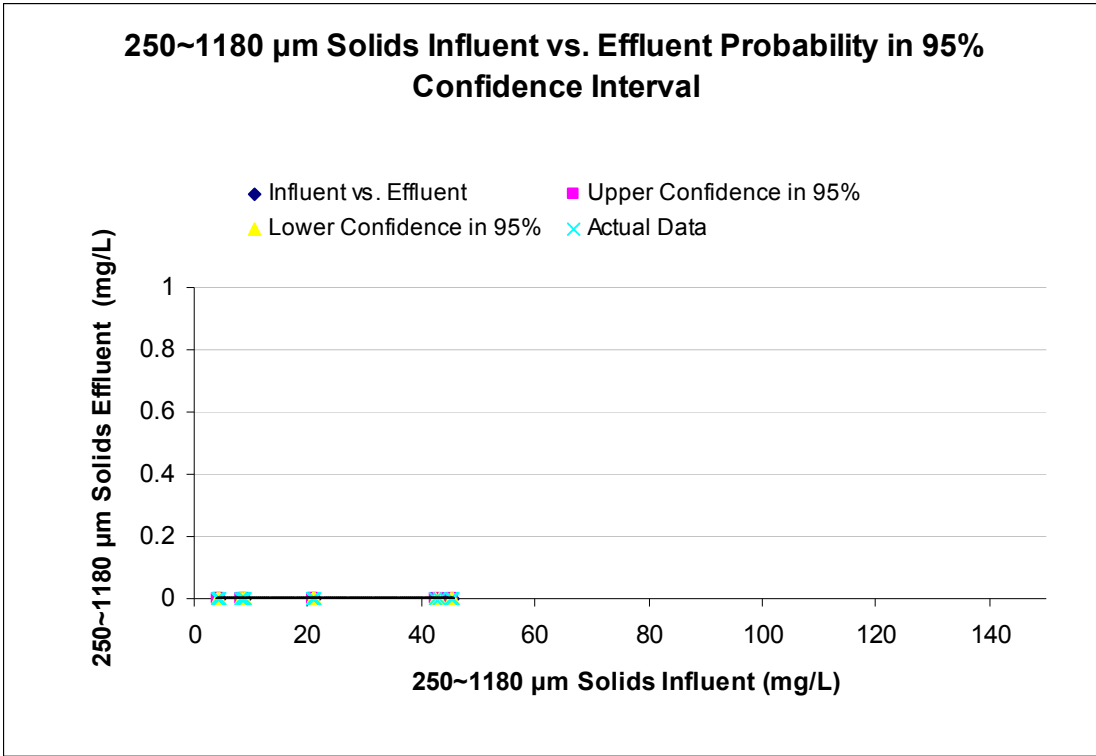

Appendix G.40: Mixed Media 25gpm >1180 μm Probability Analysis Detail

SUMMARY OUTPUT

<i>Regression Statistics</i>	
Multiple R	1
R Square	1
Adjusted R Square	1
Standard Error	0
Observations	16

ANOVA

	<i>df</i>	<i>SS</i>	<i>MS</i>	<i>F</i>	<i>Significance F</i>
Regression	1	0	0	#NUM!	#NUM!
Residual	14	0	0		
Total	15	0			

	<i>Coefficients</i>	<i>Standard Error</i>	<i>t Stat</i>	<i>P-value</i>	<i>Lower 95%</i>	<i>Upper 95%</i>	<i>Lower 90.0%</i>	<i>Upper 90.0%</i>
Intercept	0	0	65535	#NUM!	0	0	0	0
X Variable 1	0	0	65535	#NUM!	0	0	0	0

Mann-Whitney-Wilcoxon Test

n_1	16
n_2	16
Observed T	392.000
Expected T	264.000
Std. Dev. T	26.533
Test Statistic	4.824
p-Value (lower tail)	0.999999
p-Value (upper tail)	0.000
p-Value (two-tailed)	0.000
Reject H_0 , if p-Value < 0.05	
Significant Diff? Yes	
H_0 : Influent and Effluent Concentration is Same	
H_a : Influent and Effluent Concentration is Differ	

>1180 μm Solids Influent vs. Effluent Probability in 95% Confidence Interval

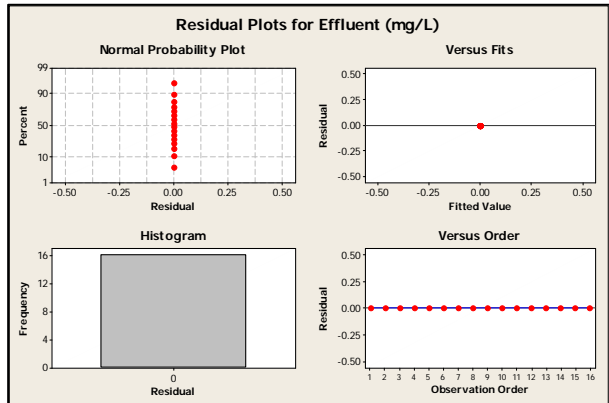
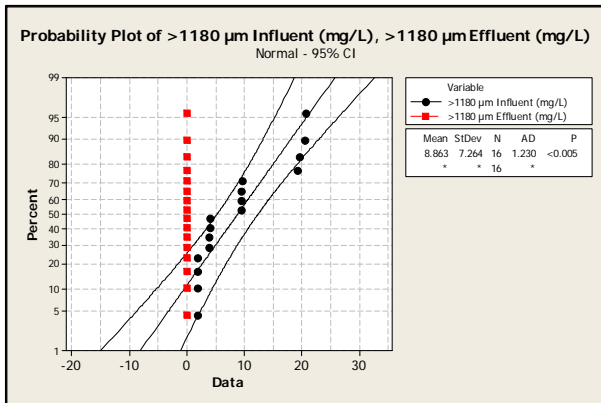
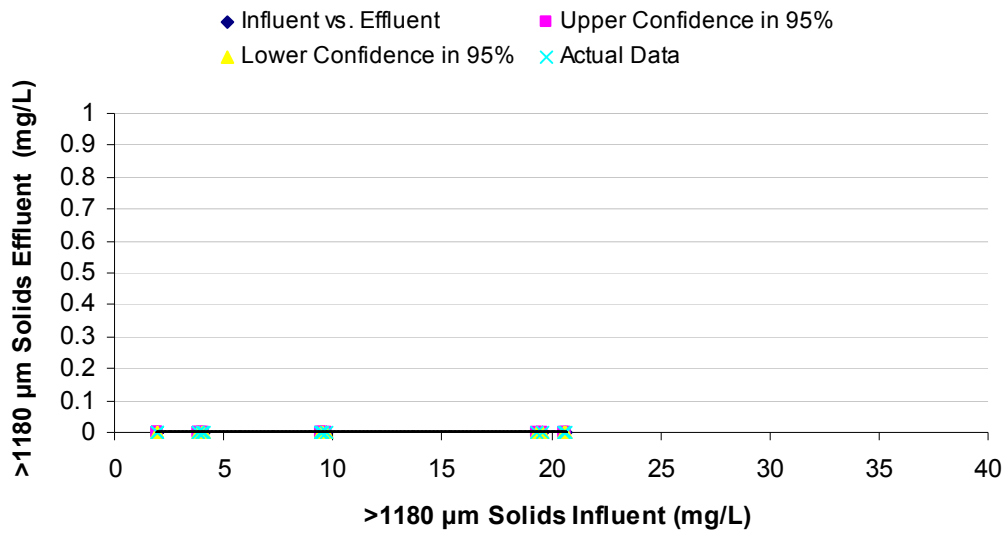

Appendix G.41: Mixed Media 75gpm TSS Probability Analysis Detail

SUMMARY OUTPUT

<i>Regression Statistics</i>	
Multiple R	0.990
R Square	0.979
Adjusted R Square	0.978
Standard Error	4.864
Observations	16.000

ANOVA					
	<i>df</i>	<i>SS</i>	<i>MS</i>	<i>F</i>	<i>Significance F</i>
Regression	1.000	15630.707	15630.707	660.550	0.000
Residual	14.000	331.284	23.663		
Total	15.000	15961.991			

	<i>Coefficients</i>	<i>Standard Error</i>	<i>t Stat</i>	<i>P-value</i>	<i>Lower 95%</i>	<i>Upper 95%</i>	<i>Lower 95.0%</i>	<i>Upper 95.0%</i>
Intercept	14.754	2.019	7.308	0.000	10.424	19.085	10.424	19.085
X Variable 1	0.212	0.008	25.701	0.000	0.194	0.230	0.194	0.230

Mann-Whitney-Wilcoxon Test

n_1	16
n_2	16
Observed T	344.000
Expected T	264.000
Std. Dev. T	26.533
Test Statistic	3.015
p-Value (lower tail)	0.998716
p-Value (upper tail)	0.001
p-Value (two tail)	0.003 Reject H_0 , if p-Value < 0.05
Significant Diff?	Yes
H_0 : Influent and Effluent Concentration is Same	
H_a : Influent and Effluent Concentration is Differ	

TSS Influent vs. Effluent Probability in 95% Confidence Interval

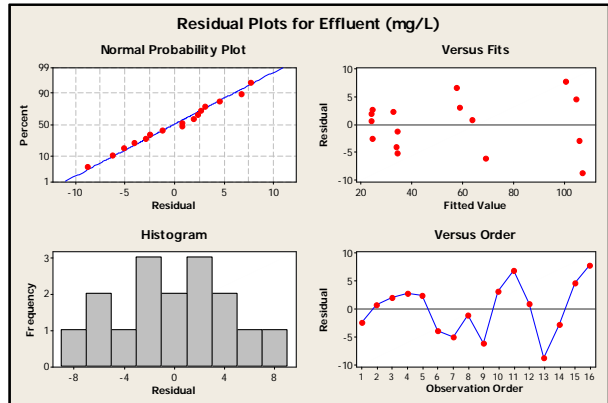
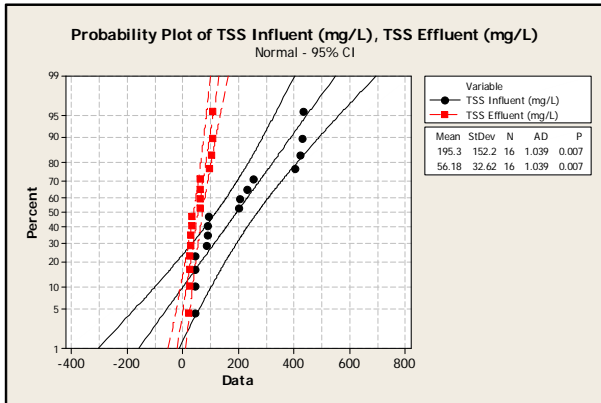
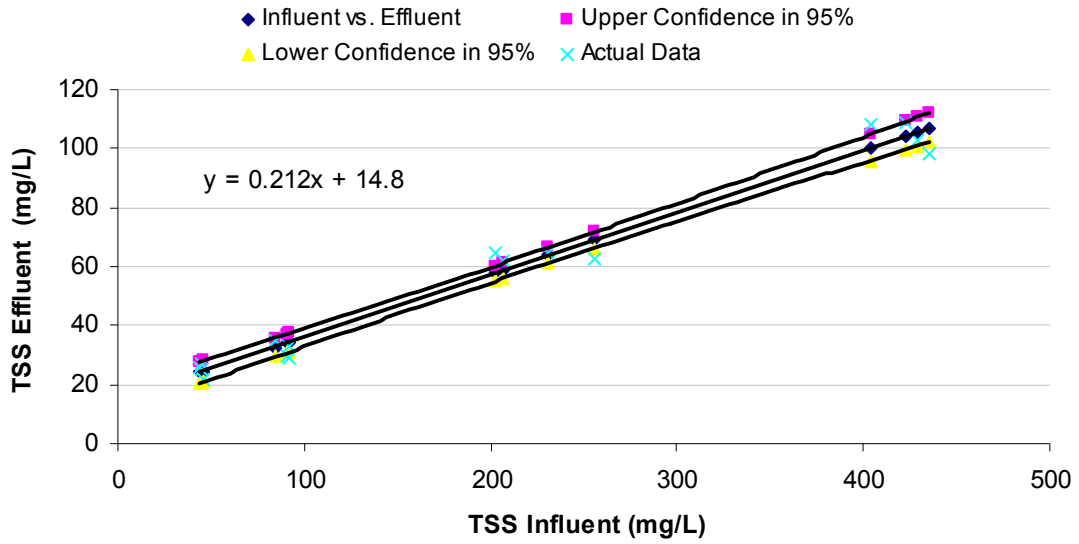

Appendix G.42: Mixed Media 75gpm TDS Probability Analysis Detail

SUMMARY OUTPUT

<i>Regression Statistics</i>	
Multiple R	0.134
R Square	0.018
Adjusted R Square	-0.052
Standard Error	8.647
Observations	16.000

ANOVA

	<i>df</i>	<i>SS</i>	<i>MS</i>	<i>F</i>	<i>Significance F</i>
Regression	1.000	19.079	19.079	0.255	0.621
Residual	14.000	1046.671	74.762		
Total	15.000	1065.750			

	<i>Coefficients</i>	<i>Standard Error</i>	<i>t Stat</i>	<i>P-value</i>	<i>Lower 95%</i>	<i>Upper 95%</i>	<i>Lower 95.0%</i>	<i>Upper 95.0%</i>
Intercept	122.412	31.326	3.908	0.002	55.224	189.600	55.224	189.600
X Variable 1	-0.113	0.223	-0.505	0.621	-0.590	0.365	-0.590	0.365

Mann-Whitney-Wilcoxon Test

n ₁	16
n ₂	16
Observed T	392.000
Expected T	264.000
Std. Dev. T	26.533
Test Statistic	4.824
p-Value (lower t	0.999999
p-Value (upper	0.000
p-Value (two ta	0.000

Reject H₀, if p-Value < 0.05

Significant Diff? Yes

H₀: Influent and Effluent Concentration is Same
H_a: Influent and Effluent Concentration is Differ

TDS Influent vs. Effluent Probability in 95% Confidence Interval

- ◆ Influent vs. Effluent
- ▲ Lower Confidence in 95%
- Upper Confidence in 95%
- × Actual Data

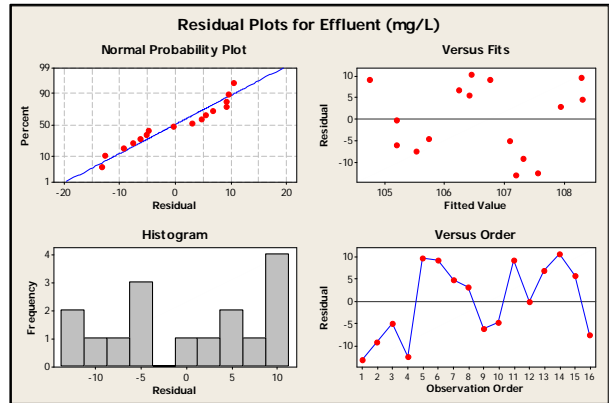
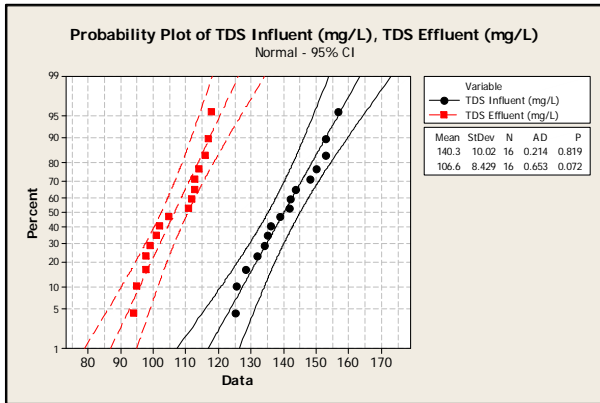
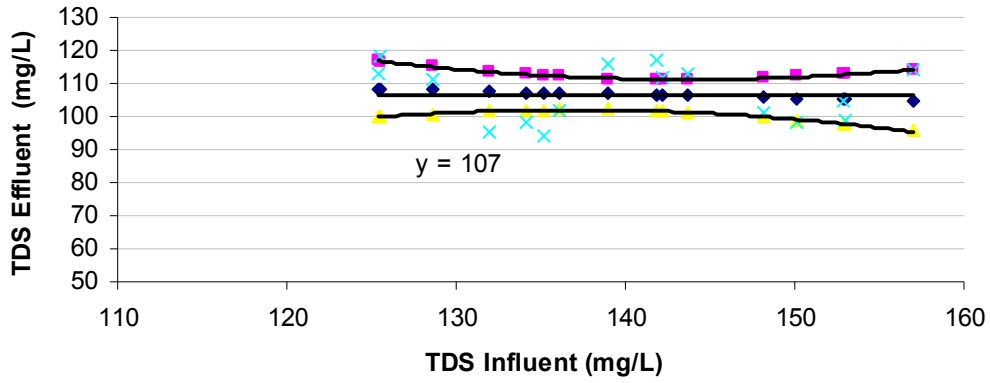

Appendix G.43: Mixed Media 75gpm 0.45-3 μm Probability Analysis Detail

SUMMARY OUTPUT

<i>Regression Statistics</i>	
Multiple R	0.984
R Square	0.969
Adjusted R Square	0.967
Standard Error	0.333
Observations	16.000

ANOVA					
	<i>df</i>	<i>SS</i>	<i>MS</i>	<i>F</i>	<i>Significance F</i>
Regression	1.000	48.562	48.562	437.125	0.000
Residual	14.000	1.555	0.111		
Total	15.000	50.117			

	<i>Coefficients</i>	<i>Standard Error</i>	<i>t Stat</i>	<i>P-value</i>	<i>Lower 95%</i>	<i>Upper 95%</i>	<i>Lower 95.0%</i>	<i>Upper 95.0%</i>
Intercept	2.133	0.140	15.184	0.000	1.832	2.434	1.832	2.434
X Variable 1	0.175	0.008	20.908	0.000	0.157	0.193	0.157	0.193

Mann-Whitney-Wilcoxon Test

n_1	16
n_2	16
Observed T	344.000
Expected T	264.000
Std. Dev. T	26.533
Test Statistic	3.015
p-Value (lower)	0.998716
p-Value (upper)	0.001
p-Value (two ta	0.003
Reject H_0 , if p-Value < 0.05	
Significant Diff? Yes	
H_0 : Influent and Effluent Concentration is Same	
H_a : Influent and Effluent Concentration is Differ	

0.45~3 μm Solids Influent vs. Effluent Probability in 95% Confidence Interval

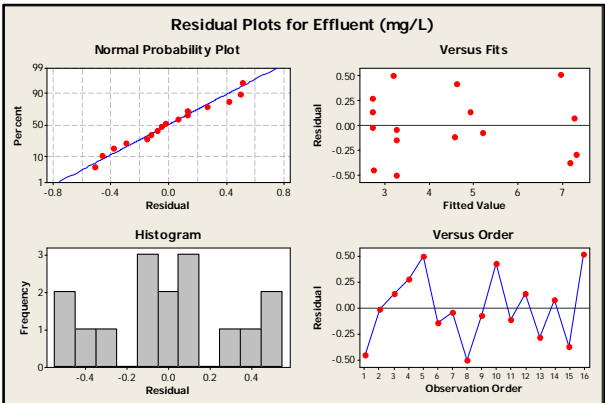
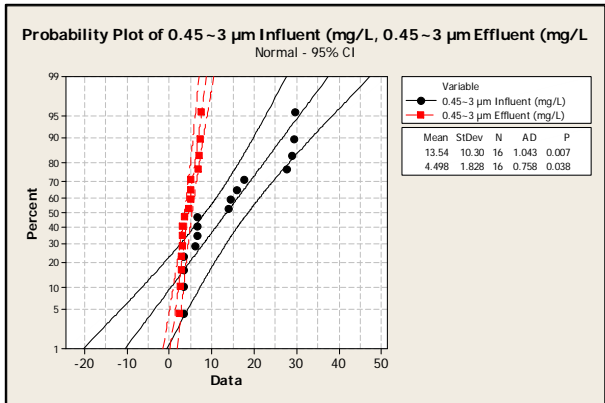
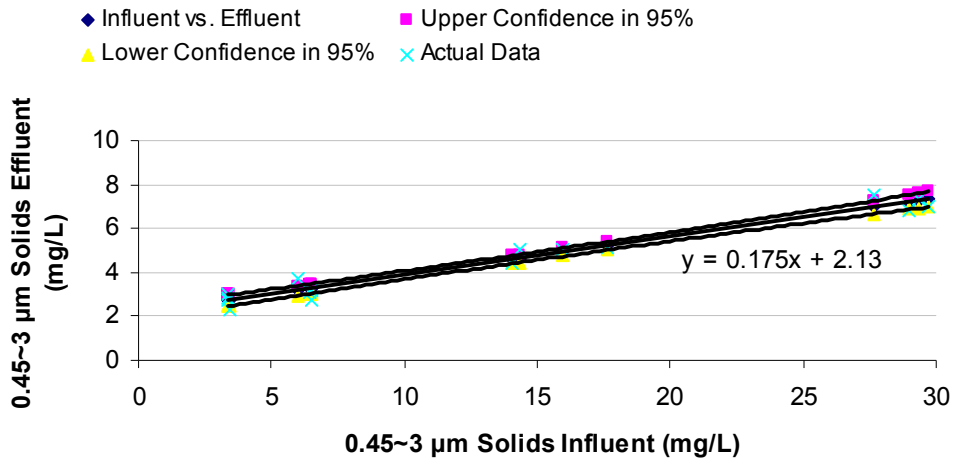

Appendix G.44: Mixed Media 75gpm 3-12 μm Probability Analysis Detail

SUMMARY OUTPUT

<i>Regression Statistics</i>	
Multiple R	0.991
R Square	0.983
Adjusted R Square	0.982
Standard Error	1.553
Observations	16.000

ANOVA					
	<i>df</i>	<i>SS</i>	<i>MS</i>	<i>F</i>	<i>Significance F</i>
Regression	1.000	1929.310	1929.310	800.097	0.000
Residual	14.000	33.759	2.411		
Total	15.000	1963.069			

	<i>Coefficients</i>	<i>Standard Error</i>	<i>t Stat</i>	<i>P-value</i>	<i>Lower 95%</i>	<i>Upper 95%</i>	<i>Lower 95.0%</i>	<i>Upper 95.0%</i>
Intercept	5.450	0.652	8.364	0.000	4.052	6.847	4.052	6.847
X Variable 1	0.287	0.010	28.286	0.000	0.266	0.309	0.266	0.309

Mann-Whitney-Wilcoxon Test

n_1	16
n_2	16
Observed T	334.000
Expected T	264.000
Std. Dev. T	26.533
Test Statistic	2.638
p-Value (lower t	0.995833
p-Value (upper	0.004
p-Value (two ta	0.008
Reject H_0 , if p-Value < 0.05	
Significant Diff? Yes	
H_0 : Influent and Effluent Concentration is Same	
H_a : Influent and Effluent Concentration is Differ	

3~12 μm Solids Influent vs. Effluent Probability in 95% Confidence Interval

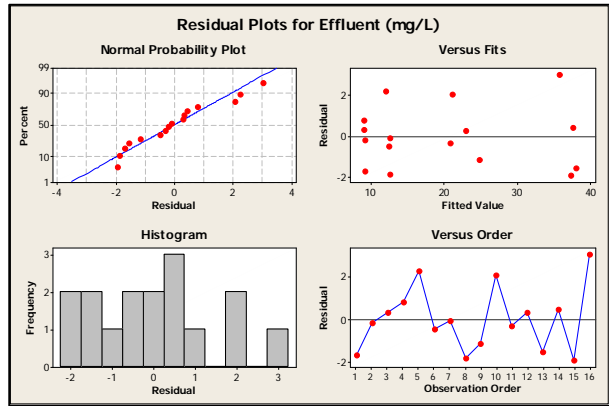
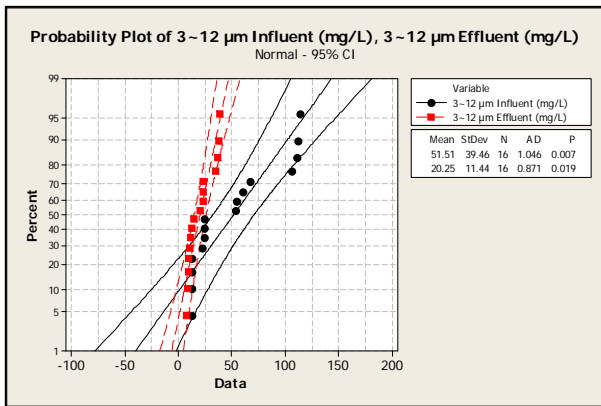
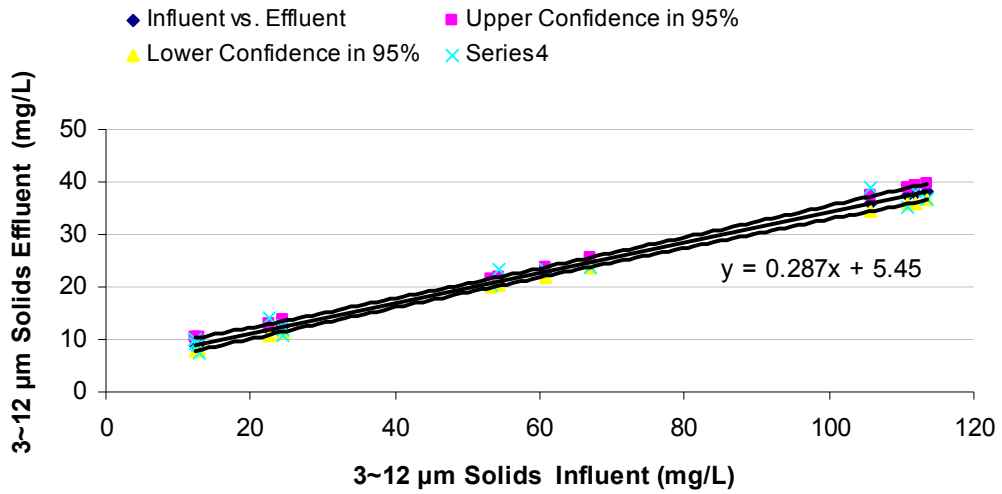

Appendix G.45: Mixed Media 75gpm 12-30 μm Probability Analysis Detail

SUMMARY OUTPUT

<i>Regression Statistics</i>	
Multiple R	0.997
R Square	0.994
Adjusted R Square	0.928
Standard Error	1.641
Observations	16.000

ANOVA					
	<i>df</i>	<i>SS</i>	<i>MS</i>	<i>F</i>	<i>Significance F</i>
Regression	1.000	6965.888	6965.888	2586.469	0.000
Residual	15.000	40.398	2.693		
Total	16.000	7006.286			

	<i>Coefficients</i>	<i>Standard Error</i>	<i>t Stat</i>	<i>P-value</i>	<i>Lower 95%</i>	<i>Upper 95%</i>	<i>Lower 95.0%</i>	<i>Upper 95.0%</i>
Intercept	0.000	#N/A	#N/A	#N/A	#N/A	#N/A	#N/A	#N/A
X Variable 1	0.264	0.005	50.857	0.000	0.253	0.275	0.253	0.275

Mann-Whitney-Wilcoxon Test

n_1	16
n_2	16
Observed T	344.000
Expected T	264.000
Std. Dev. T	26.533
Test Statistic	3.015
p-Value (lower tail)	0.998716
p-Value (upper tail)	0.001
p-Value (two tail)	0.003
Reject H_0 , if p-Value < 0.05	
Significant Diff? Yes	
H_0 : Influent and Effluent Concentration is Same	
H_a : Influent and Effluent Concentration is Differ	

12~30 μm Solids Influent vs. Effluent Probability in 95% Confidence Interval

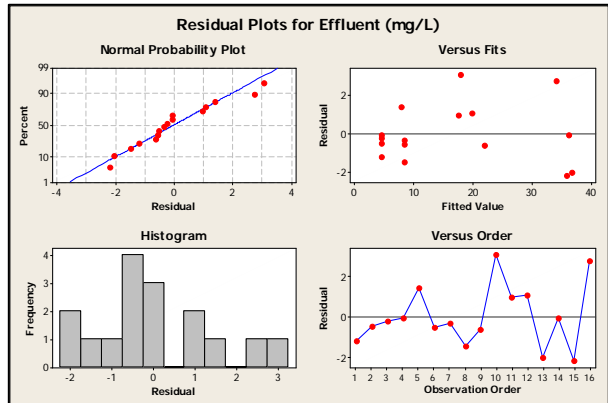
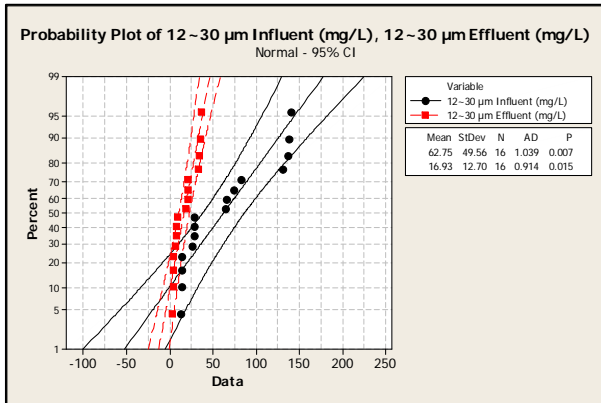
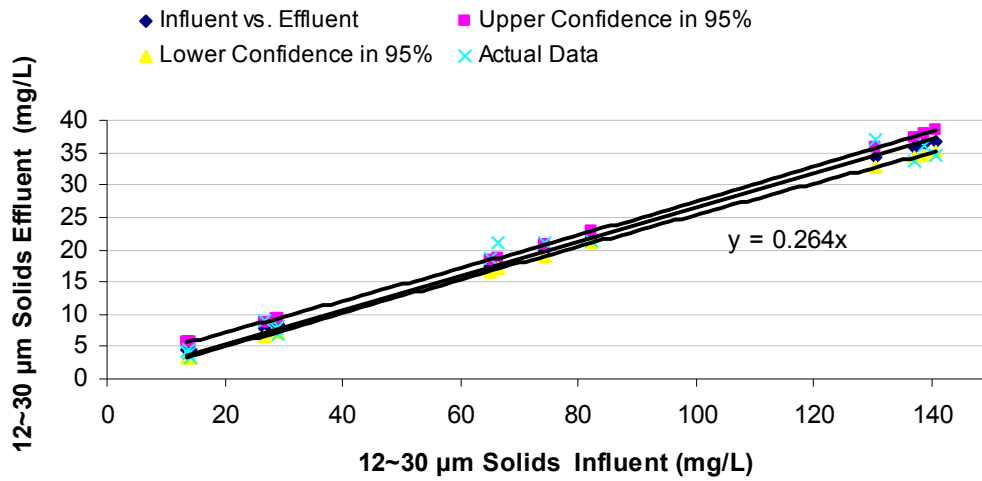

Appendix G.46: Mixed Media 75gpm 30-60 μm Probability Analysis Detail

SUMMARY OUTPUT

<i>Regression Statistics</i>	
Multiple R	0.991
R Square	0.981
Adjusted R Square	0.980
Standard Error	0.717
Observations	16.000

ANOVA

	<i>df</i>	<i>SS</i>	<i>MS</i>	<i>F</i>	<i>Significance F</i>
Regression	1.000	373.974	373.974	728.080	0.000
Residual	14.000	7.191	0.514		
Total	15.000	381.165			

	<i>Coefficients</i>	<i>Standard Error</i>	<i>t Stat</i>	<i>P-value</i>	<i>Lower 95%</i>	<i>Upper 95%</i>	<i>Lower 95.0%</i>	<i>Upper 95.0%</i>
Intercept	1.048	0.295	3.550	0.003	0.415	1.681	0.415	1.681
X Variable 1	0.192	0.007	26.983	0.000	0.177	0.207	0.177	0.207

Mann-Whitney-Wilcoxon Test

n_1	16
n_2	16
Observed T	355.000
Expected T	264.000
Std. Dev. T	26.533
Test Statistic	3.430
p-Value (lower t	0.999698
p-Value (upper	0.000
p-Value (two ta	0.001

Reject H_0 , if p-Value < 0.05

Significant Diff? Yes

H_0 : Influent and Effluent Concentration is Same
 H_a : Influent and Effluent Concentration is Differ

30~60 μm Solids Influent vs. Effluent Probability in 95% Confidence Interval

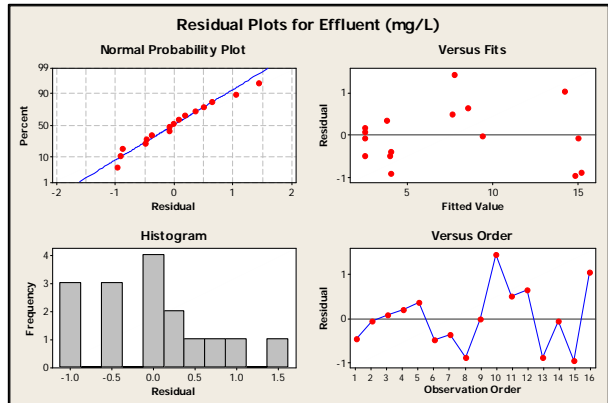
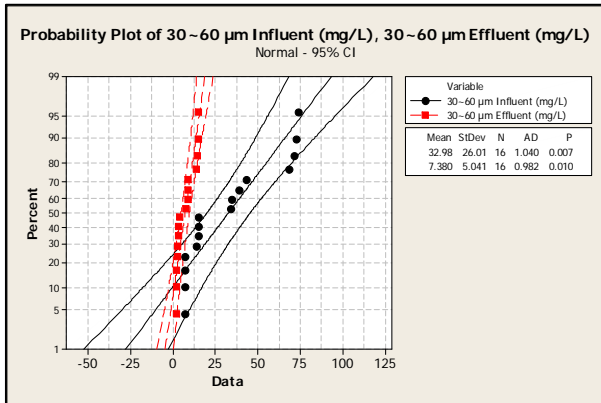
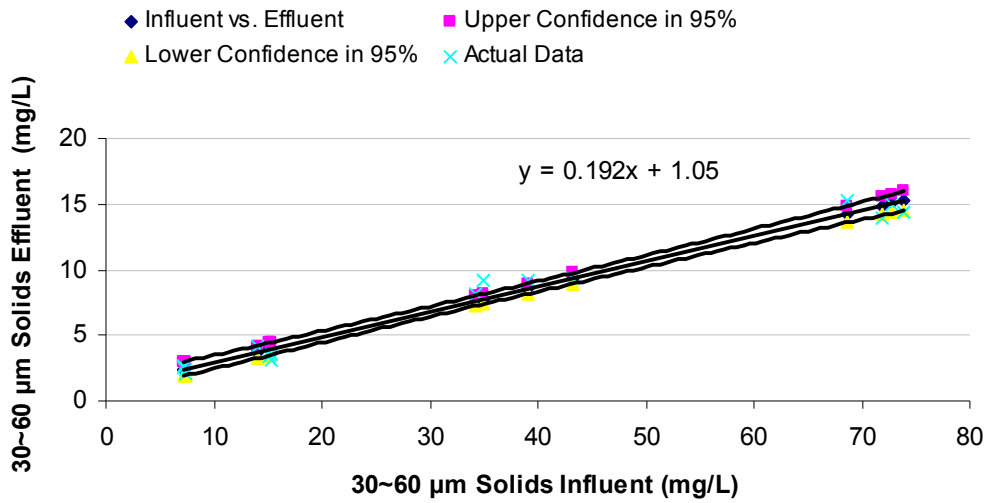

Appendix G.47: Mixed Media 75gpm 60-120 μm Probability Analysis Detail

SUMMARY OUTPUT

<i>Regression Statistics</i>	
Multiple R	0.819
R Square	0.670
Adjusted R Square	0.647
Standard Error	0.231
Observations	16.000

ANOVA

	<i>df</i>	<i>SS</i>	<i>MS</i>	<i>F</i>	<i>Significance F</i>
Regression	1.000	1.520	1.520	28.447	0.000
Residual	14.000	0.748	0.053		
Total	15.000	2.268			

	<i>Coefficients</i>	<i>Standard Error</i>	<i>t Stat</i>	<i>P-value</i>	<i>Lower 95%</i>	<i>Upper 95%</i>	<i>Lower 95.0%</i>	<i>Upper 95.0%</i>
Intercept	0.609	0.096	6.323	0.000	0.402	0.815	0.402	0.815
X Variable 1	0.102	0.019	5.334	0.000	0.061	0.142	0.061	0.142

Mann-Whitney-Wilcoxon Test

n_1	16
n_2	16
Observed T	360.000
Expected T	264.000
Std. Dev. T	26.533
Test Statistic	3.618
p-Value (lower tail)	0.999852
p-Value (upper tail)	0.000
p-Value (two-tailed)	0.000
Reject H_0 , if p-Value < 0.05	
Significant Diff? Yes	
H_0 : Influent and Effluent Concentration is Same	
H_a : Influent and Effluent Concentration is Differ	

60~120 µm Solids Influent vs. Effluent Probability in 95% Confidence Interval

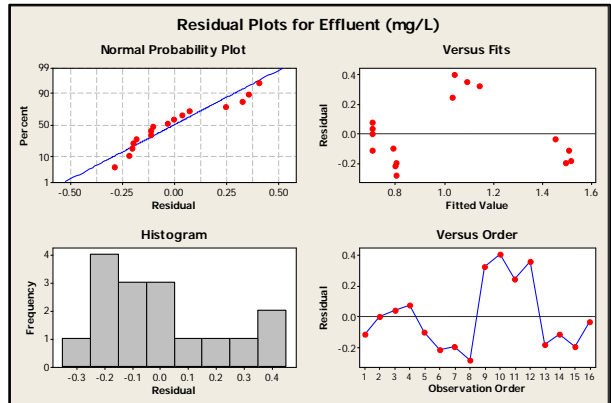
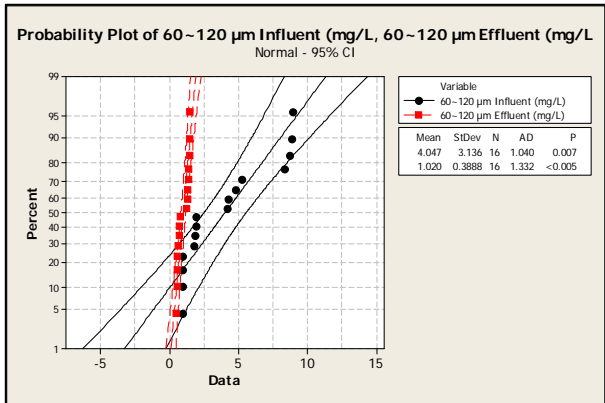
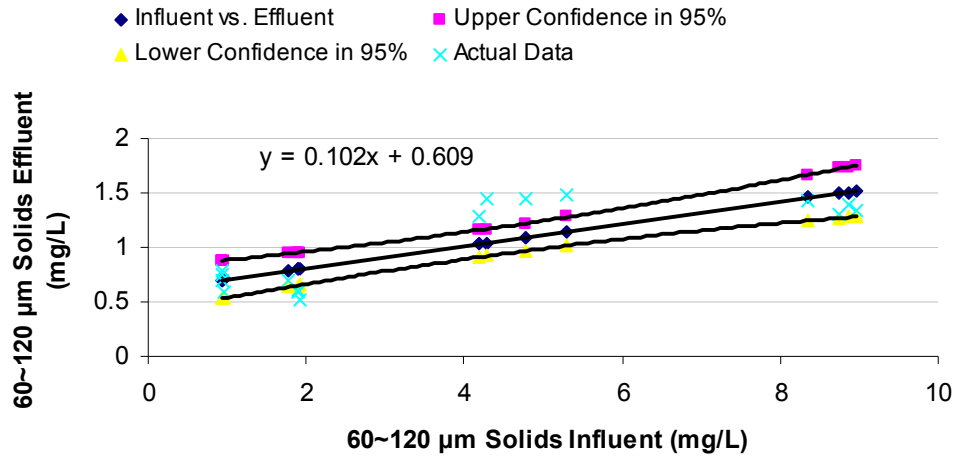

Appendix G.48: Mixed Media 75gpm 120-250 μ m Probability Analysis Detail

SUMMARY OUTPUT

<i>Regression Statistics</i>	
Multiple R	0.825
R Square	0.681
Adjusted R Square	0.658
Standard Error	0.069
Observations	16.000

ANOVA

	<i>df</i>	<i>SS</i>	<i>MS</i>	<i>F</i>	<i>Significance F</i>
Regression	1.000	0.144	0.144	29.879	0.000
Residual	14.000	0.068	0.005		
Total	15.000	0.212			

	<i>Coefficients</i>	<i>Standard Error</i>	<i>t Stat</i>	<i>P-value</i>	<i>Lower 95%</i>	<i>Upper 95%</i>	<i>Lower 95.0%</i>	<i>Upper 95.0%</i>
Intercept	0.290	0.029	10.149	0.000	0.228	0.351	0.228	0.351
X Variable 1	-0.060	0.011	-5.466	0.000	-0.084	-0.037	-0.084	-0.037

Mann-Whitney-Wilcoxon Test

n_1	16
n_2	16
Observed T	392.000
Expected T	264.000
Std. Dev. T	26.533
Test Statistic	4.824
p-Value (lower)	0.999999
p-Value (upper)	0.000
p-Value (two ta	0.000
Reject H_0 , if p-Value < 0.05	
Significant Diff? Yes	
H_0 : Influent and Effluent Concentration is Same	
H_a : Influent and Effluent Concentration is Differ	

120~250 μ m Solids Influent vs. Effluent Probability in 95% Confidence Interval

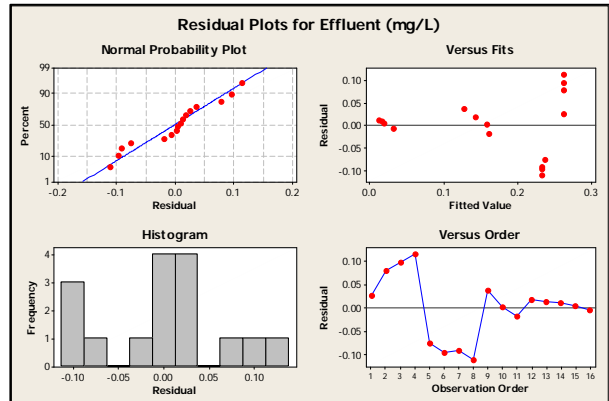
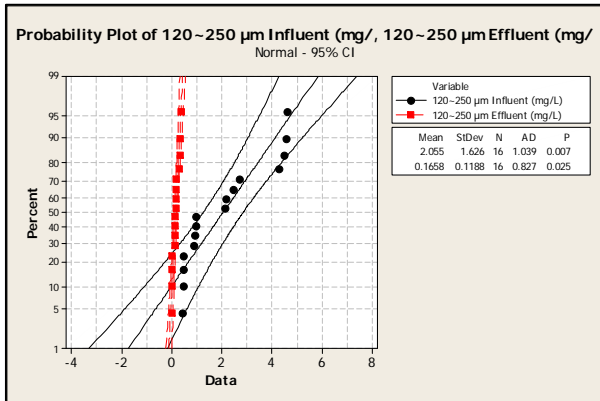
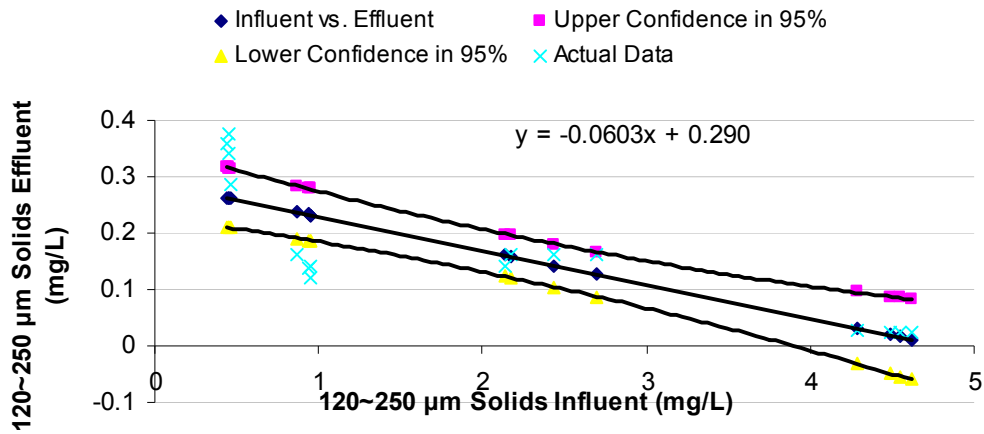

Appendix G.49: Mixed Media 75gpm 250-1180 μm Probability Analysis Detail

SUMMARY OUTPUT

<i>Regression Statistics</i>	
Multiple R	1
R Square	1
Adjusted R Square	1
Standard Error	0
Observations	16

ANOVA

	<i>df</i>	<i>SS</i>	<i>MS</i>	<i>F</i>	<i>Significance F</i>
Regression	1	0	0	#NUM!	#NUM!
Residual	14	0	0		
Total	15	0			

	<i>Coefficients</i>	<i>Standard Error</i>	<i>t Stat</i>	<i>P-value</i>	<i>Lower 95%</i>	<i>Upper 95%</i>	<i>Lower 90.0%</i>	<i>Upper 90.0%</i>
Intercept	0	0	65535	#NUM!	0	0	0	0
X Variable 1	0	0	65535	#NUM!	0	0	0	0

Mann-Whitney-Wilcoxon Test

n_1	16
n_2	16
Observed T	392.000
Expected T	264.000
Std. Dev. T	26.533
Test Statistic	4.824
p-Value (lower tail)	0.999999
p-Value (upper tail)	0.000
p-Value (two-tailed)	0.000
Reject H_0 , if p-Value < 0.05	
Significant Diff? Yes	
H_0 : Influent and Effluent Concentration is Same	
H_a : Influent and Effluent Concentration is Differ	

250~1180 μm Solids Influent vs. Effluent Probability in 95% Confidence Interval

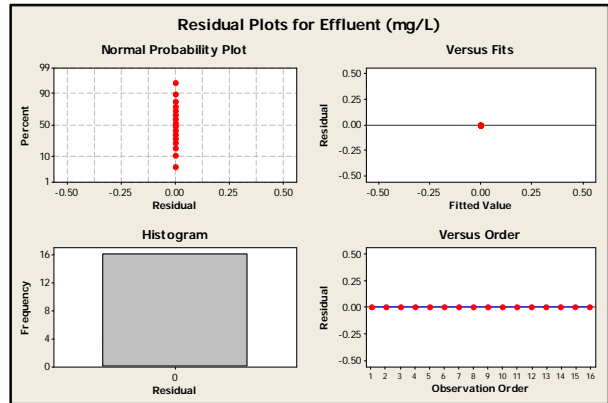
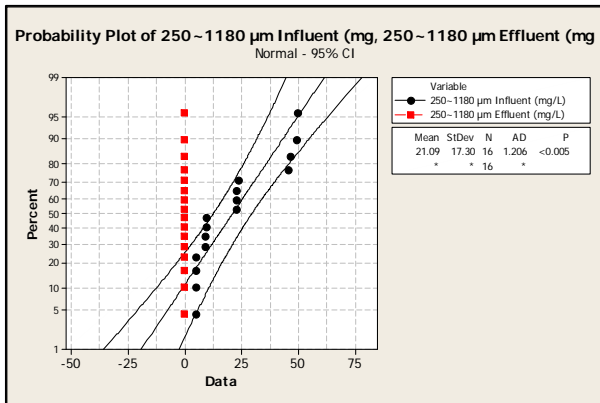
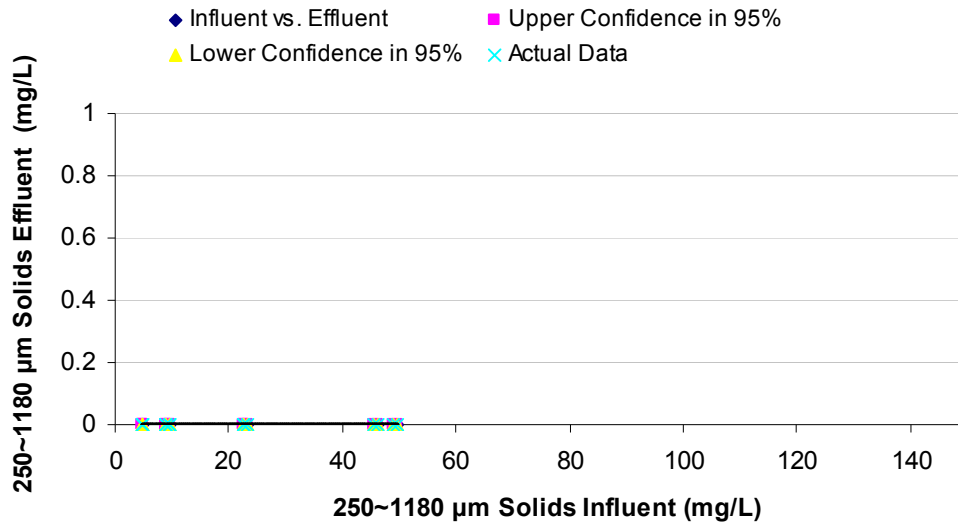

Appendix G.50: Mixed Media 75gpm >1180 μ m Probability Analysis Detail

SUMMARY OUTPUT

<i>Regression Statistics</i>	
Multiple R	1
R Square	1
Adjusted R Square	1
Standard Error	0
Observations	16

ANOVA

	<i>df</i>	<i>SS</i>	<i>MS</i>	<i>F</i>	<i>Significance F</i>
Regression	1	0	0	#NUM!	#NUM!
Residual	14	0	0		
Total	15	0			

	<i>Coefficients</i>	<i>Standard Error</i>	<i>t Stat</i>	<i>P-value</i>	<i>Lower 95%</i>	<i>Upper 95%</i>	<i>Lower 90.0%</i>	<i>Upper 90.0%</i>
Intercept	0	0	65535	#NUM!	0	0	0	0
X Variable 1	0	0	65535	#NUM!	0	0	0	0

Mann-Whitney-Wilcoxon Test

n_1	16
n_2	16
Observed T	392.000
Expected T	264.000
Std. Dev. T	26.533
Test Statistic	4.824
p-Value (lower)	0.999999
p-Value (upper)	0.000
p-Value (two ta	0.000
Reject H_0 , if p-Value < 0.05	
Significant Diff? Yes	
H_0 : Influent and Effluent Concentration is Same	
H_a : Influent and Effluent Concentration is Differ	

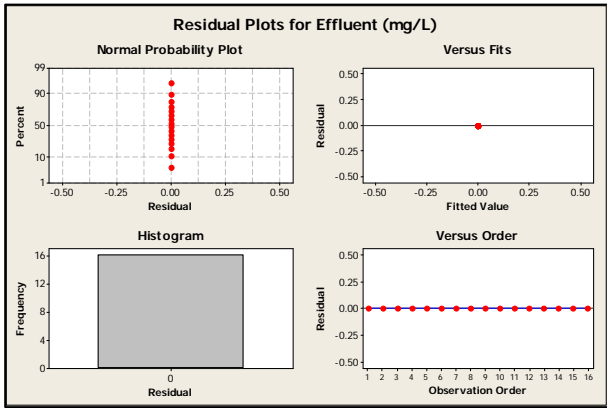
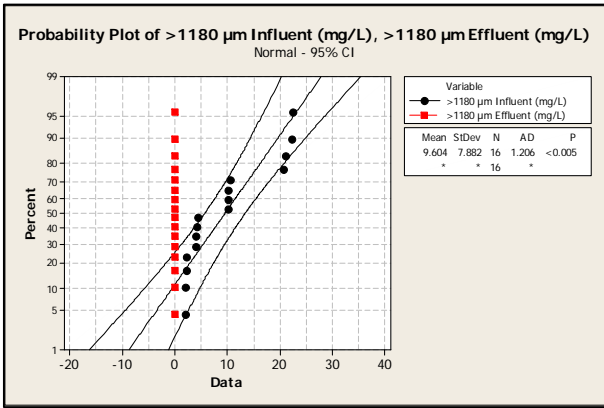
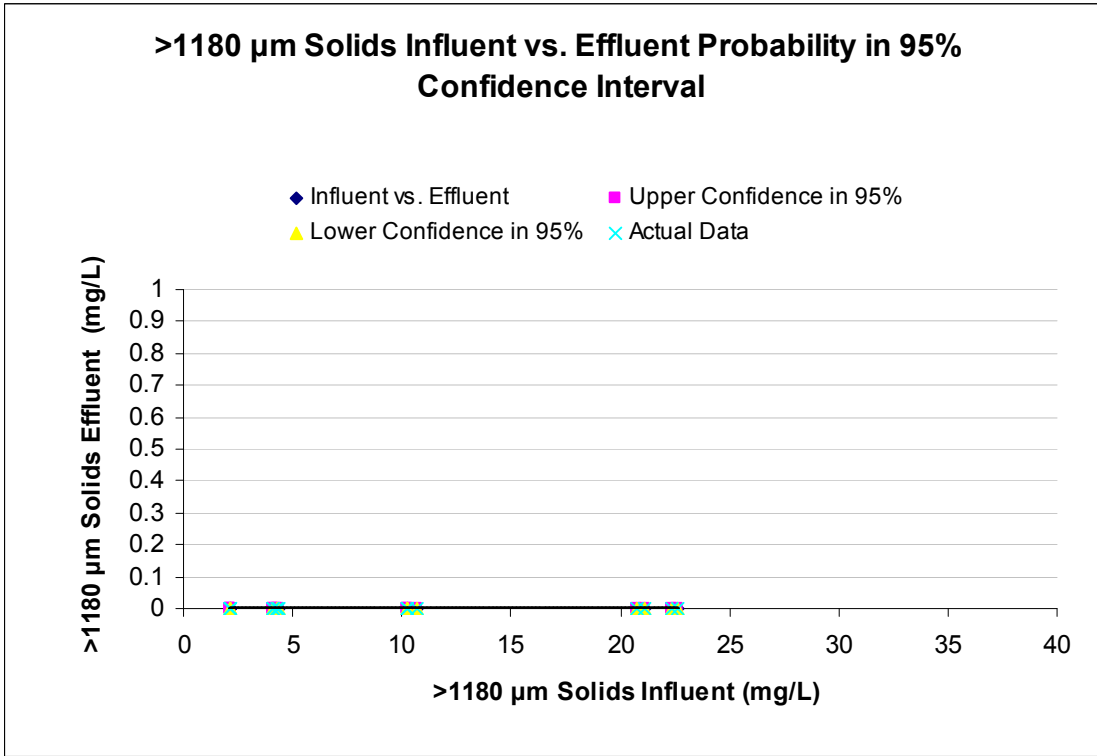

Appendix G.51: Mixed Media 150gpm TSS Probability Analysis Detail

SUMMARY OUTPUT

<i>Regression Statistics</i>	
Multiple R	0.998
R Square	0.996
Adjusted R Square	0.930
Standard Error	7.533
Observations	16.000

ANOVA					
	<i>df</i>	<i>SS</i>	<i>MS</i>	<i>F</i>	<i>Significance F</i>
Regression	1.000	227975.272	227975.272	4016.958	0.000
Residual	15.000	851.298	56.753		
Total	16.000	228826.570			

	<i>Coefficients</i>	<i>Standard Error</i>	<i>t Stat</i>	<i>P-value</i>	<i>Lower 95%</i>	<i>Upper 95%</i>	<i>Lower 95.0%</i>	<i>Upper 95.0%</i>
Intercept	0.000	#N/A	#N/A	#N/A	#N/A	#N/A	#N/A	#N/A
X Variable 1	0.353	0.006	63.379	0.000	0.341	0.365	0.341	0.365

Mann-Whitney-Wilcoxon Test

n ₁	16
n ₂	16
Observed T	340.000
Expected T	264.000
Std. Dev. T	26.533
Test Statistic	2.864
p-Value (lower tail)	0.997911
p-Value (upper tail)	0.002
p-Value (two tail)	0.004
Reject H ₀ , if p-Value < 0.05	
Significant Diff?	Yes

H₀: Influent and Effluent Concentration is Same

H_a: Influent and Effluent Concentration is Differ

TSS Influent vs. Effluent Probability in 95% Confidence Interval

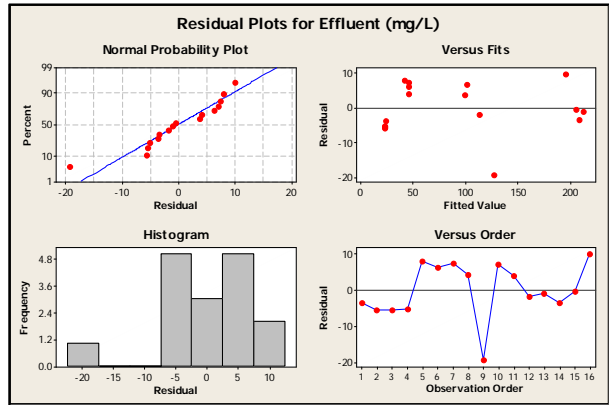
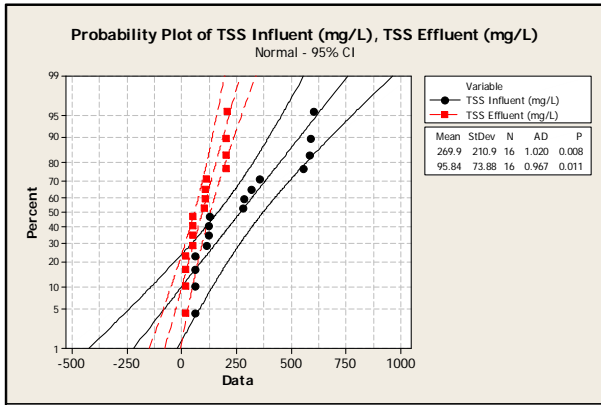
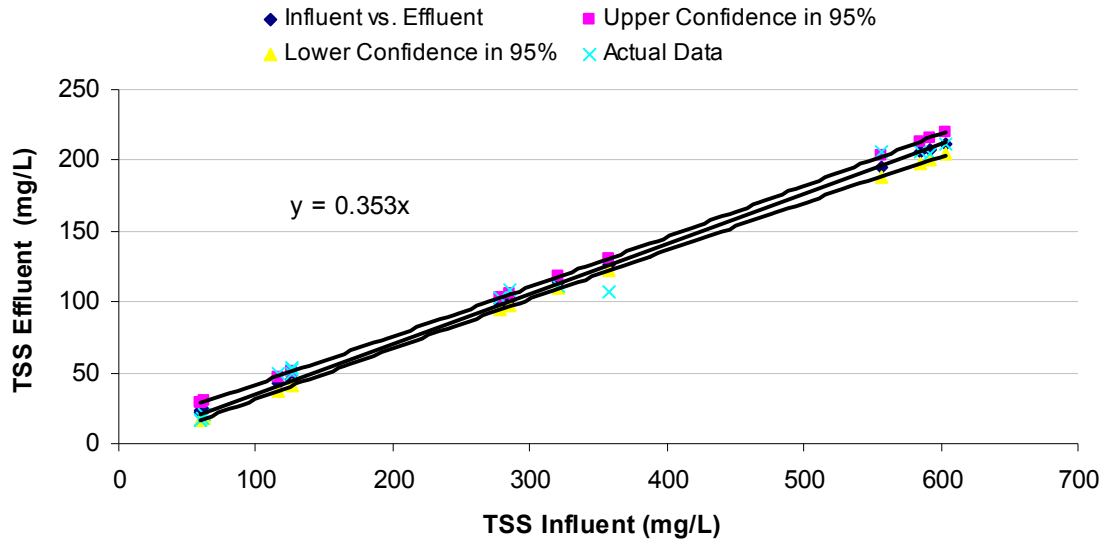

Appendix G.52: Mixed Media 150gpm TDS Probability Analysis Detail

SUMMARY OUTPUT

<i>Regression Statistics</i>	
Multiple R	0.390
R Square	0.152
Adjusted R Square	0.091
Standard Error	5.772
Observations	16.000

ANOVA					
	<i>df</i>	<i>SS</i>	<i>MS</i>	<i>F</i>	<i>Significance F</i>
Regression	1.000	83.522	83.522	2.507	0.136
Residual	14.000	466.415	33.315		
Total	15.000	549.937			

	<i>Coefficients</i>	<i>Standard Error</i>	<i>t Stat</i>	<i>P-value</i>	<i>Lower 95%</i>	<i>Upper 95%</i>	<i>Lower 95.0%</i>	<i>Upper 95.0%</i>
Intercept	80.246	15.347	5.229	0.000	47.330	113.161	47.330	113.161
X Variable 1	0.197	0.125	1.583	0.136	-0.070	0.464	-0.070	0.464

Mann-Whitney-Wilcoxon Test

n ₁	16
n ₂	16
Observed T	384.000
Expected T	264.000
Std. Dev. T	26.533
Test Statistic	4.523
p-Value (lower t	0.999997
p-Value (upper	0.000
p-Value (two ta	0.000
Reject H ₀ , if p-Value < 0.05	
Significant Diff? Yes	
H ₀ : Influent and Effluent Concentration is Same	
H _a : Influent and Effluent Concentration is Differ	

TDS Influent vs. Effluent Probability in 95% Confidence Interval

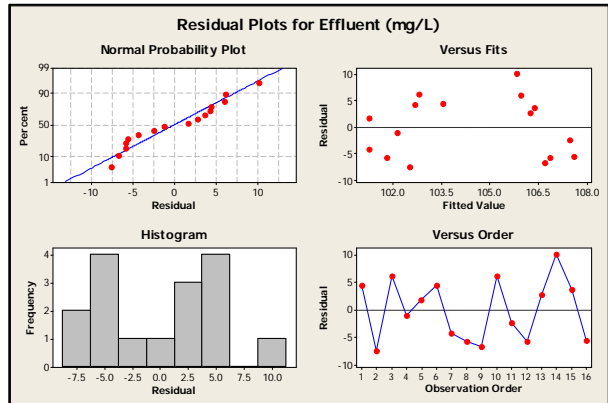
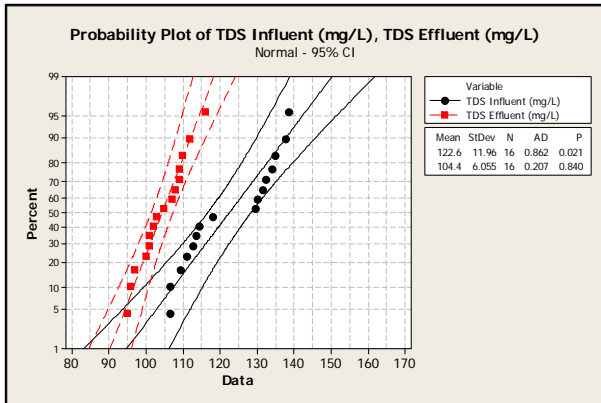
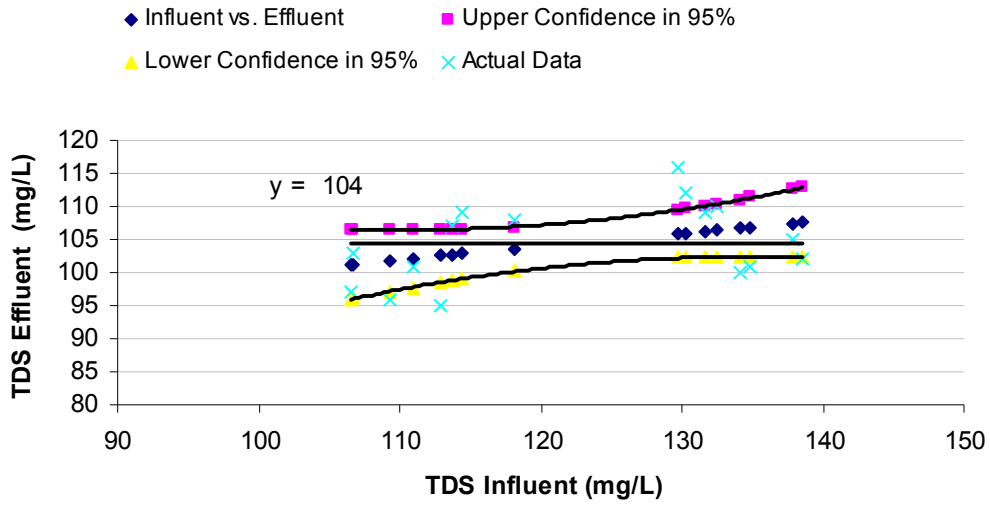

Appendix G.53: Mixed Media 150gpm 0.45-3 μm Probability Analysis Detail

SUMMARY OUTPUT

<i>Regression Statistics</i>	
Multiple R	0.942
R Square	0.887
Adjusted R Square	0.879
Standard Error	1.868
Observations	16.000

ANOVA					
	<i>df</i>	<i>SS</i>	<i>MS</i>	<i>F</i>	<i>Significance F</i>
Regression	1.000	384.486	384.486	110.167	0.000
Residual	14.000	48.860	3.490		
Total	15.000	433.346			

	<i>Coefficients</i>	<i>Standard Error</i>	<i>t Stat</i>	<i>P-value</i>	<i>Lower 95%</i>	<i>Upper 95%</i>	<i>Lower 95.0%</i>	<i>Upper 95.0%</i>
Intercept	1.576	0.785	2.008	0.064	-0.108	3.259	-0.108	3.259
X Variable 1	0.355	0.034	10.496	0.000	0.282	0.427	0.282	0.427

Mann-Whitney-Wilcoxon Test

n_1	16
n_2	16
Observed T	323.000
Expected T	264.000
Std. Dev. T	26.533
Test Statistic	2.224
p-Value (lower tail)	0.986914
p-Value (upper tail)	0.013
p-Value (two-tailed)	0.026
Reject H_0 , if p-Value < 0.05	
Significant Diff? Yes	
H_0 : Influent and Effluent Concentration is Same	
H_a : Influent and Effluent Concentration is Differ	

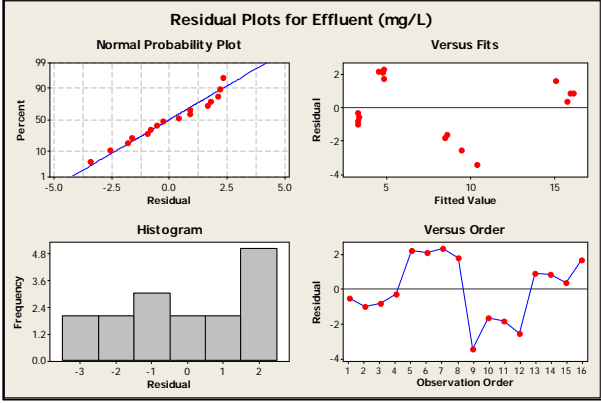
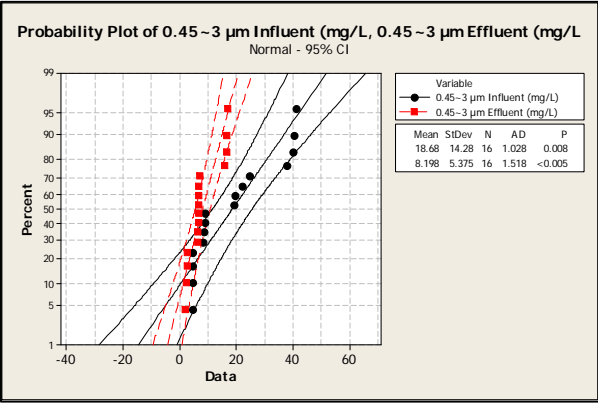
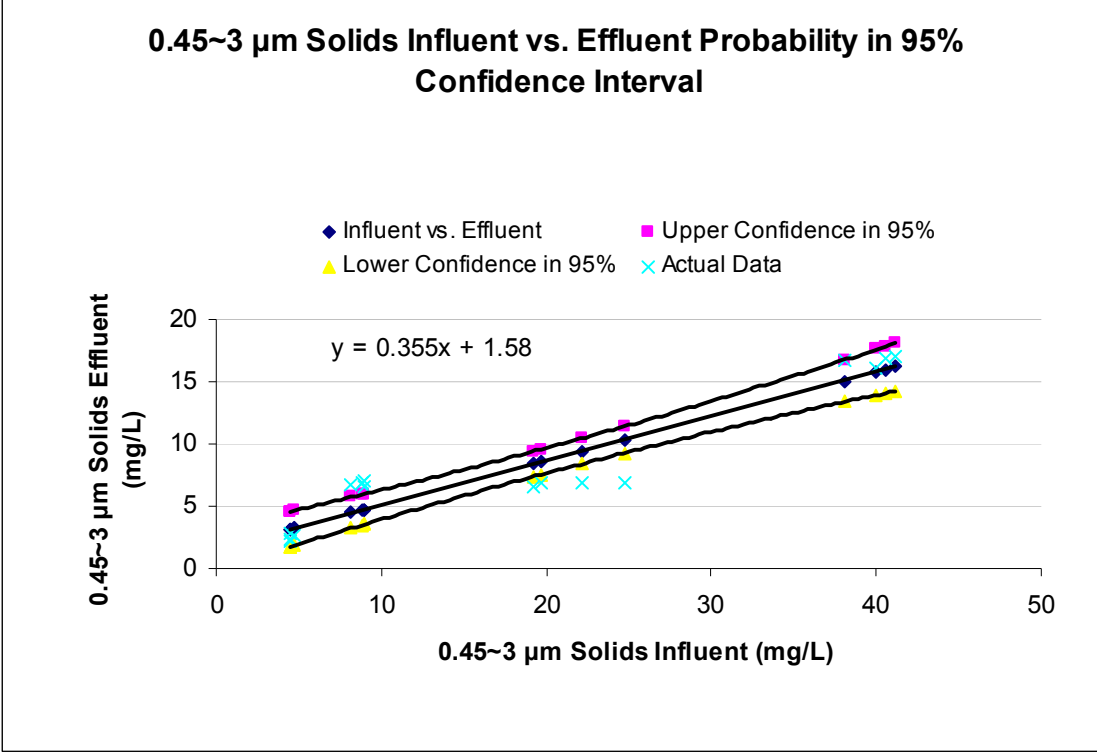

Appendix G.54: Mixed Media 150gpm 3-12 μm Probability Analysis Detail

SUMMARY OUTPUT

<i>Regression Statistics</i>	
Multiple R	0.994
R Square	0.988
Adjusted R Square	0.921
Standard Error	5.011
Observations	16.000

ANOVA					
	<i>df</i>	<i>SS</i>	<i>MS</i>	<i>F</i>	<i>Significance F</i>
Regression	1.000	30281.862	30281.862	1206.107	0.000
Residual	15.000	376.607	25.107		
Total	16.000	30658.468			

	<i>Coefficients</i>	<i>Standard Error</i>	<i>t Stat</i>	<i>P-value</i>	<i>Lower 95%</i>	<i>Upper 95%</i>	<i>Lower 95.0%</i>	<i>Upper 95.0%</i>
Intercept	0.000	#N/A	#N/A	#N/A	#N/A	#N/A	#N/A	#N/A
X Variable 1	0.493	0.014	34.729	0.000	0.463	0.523	0.463	0.523

Mann-Whitney-Wilcoxon Test

n_1	16
n_2	16
Observed T	320.000
Expected T	264.000
Std. Dev. T	26.533
Test Statistic	2.111
p-Value (lower tail)	0.982596
p-Value (upper tail)	0.017
p-Value (two tail)	0.035
Reject H_0 , if p-Value < 0.05	
Significant Diff? Yes	
H_0 : Influent and Effluent Concentration is Same	
H_a : Influent and Effluent Concentration is Differ	

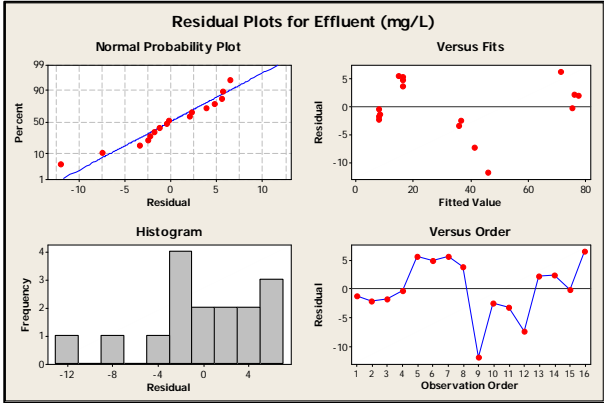
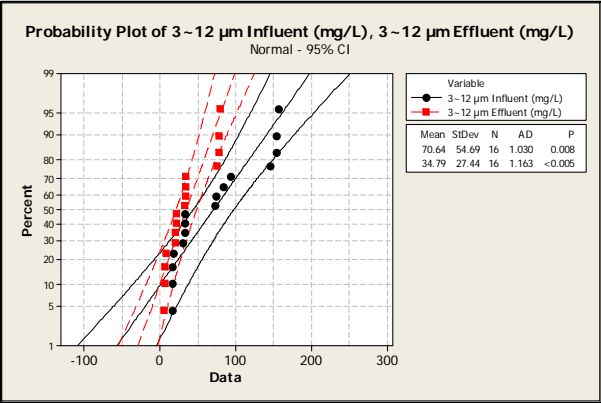
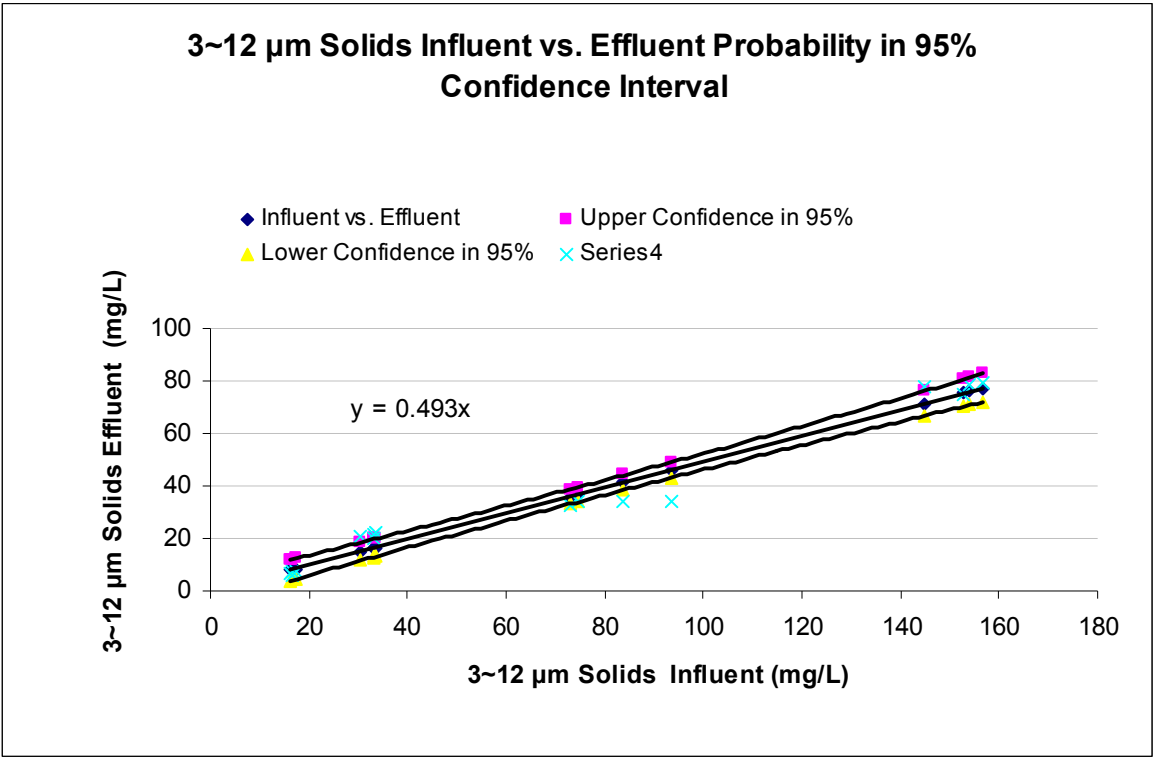

Appendix G.55: Mixed Media 150gpm 12-30 μm Probability Analysis Detail

SUMMARY OUTPUT

<i>Regression Statistics</i>	
Multiple R	0.994
R Square	0.988
Adjusted R Square	0.988
Standard Error	3.322
Observations	16.000

ANOVA					
	<i>df</i>	<i>SS</i>	<i>MS</i>	<i>F</i>	<i>Significance F</i>
Regression	1.000	13246.773	13246.773	1200.578	0.000
Residual	14.000	154.471	11.034		
Total	15.000	13401.245			

	<i>Coefficients</i>	<i>Standard Error</i>	<i>t Stat</i>	<i>P-value</i>	<i>Lower 95%</i>	<i>Upper 95%</i>	<i>Lower 95.0%</i>	<i>Upper 95.0%</i>
Intercept	-4.310	1.368	-3.151	0.007	-7.243	-1.377	-7.243	-1.377
X Variable 1	0.433	0.012	34.649	0.000	0.406	0.460	0.406	0.460

Mann-Whitney-Wilcoxon Test

n_1	16
n_2	16
Observed T	336.000
Expected T	264.000
Std. Dev. T	26.533
Test Statistic	2.714
p-Value (lower tail)	0.996672
p-Value (upper tail)	0.003
p-Value (two tail)	0.007
Reject H_0 , if p-Value < 0.05	
Significant Diff? Yes	
H_0 : Influent and Effluent Concentration is Same	
H_a : Influent and Effluent Concentration is Differ	

12~30 μm Solids Influent vs. Effluent Probability in 95% Confidence Interval

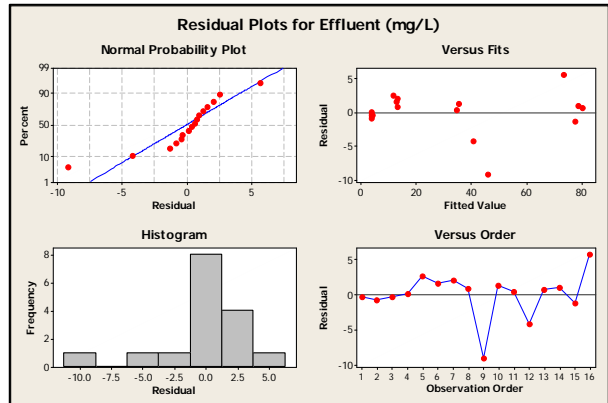
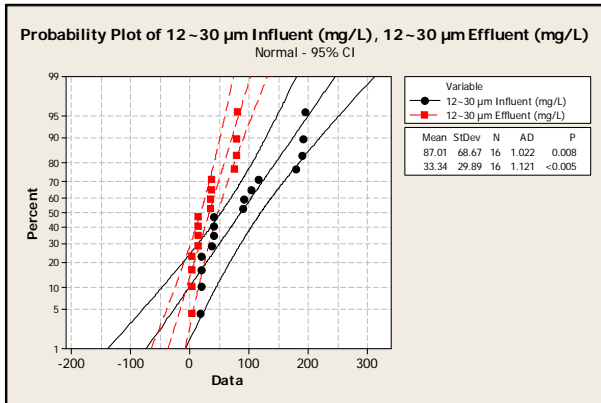
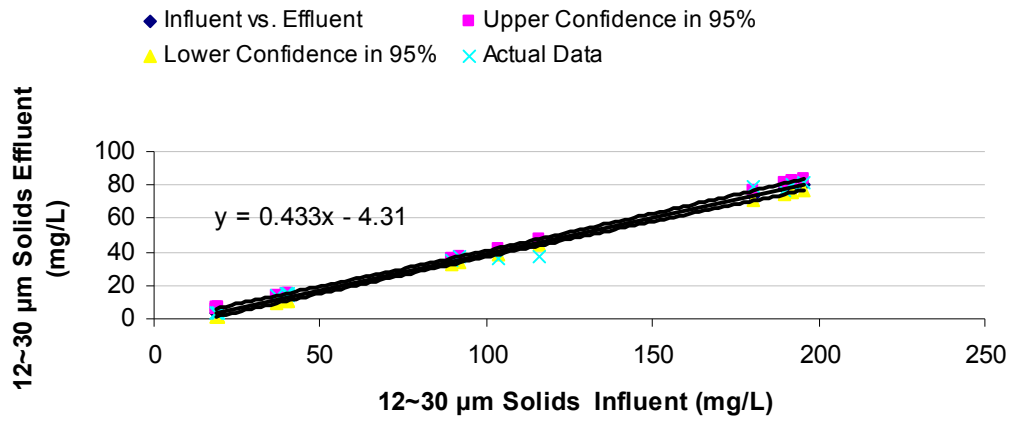

Appendix G.56: Mixed Media 150gpm 30-60 μm Probability Analysis Detail

SUMMARY OUTPUT

<i>Regression Statistics</i>	
Multiple R	0.960
R Square	0.921
Adjusted R Square	0.854
Standard Error	4.977
Observations	16.000

ANOVA					
	<i>df</i>	<i>SS</i>	<i>MS</i>	<i>F</i>	<i>Significance F</i>
Regression	1.000	4318.910	4318.910	174.390	0.000
Residual	15.000	371.487	24.766		
Total	16.000	4690.397			

	<i>Coefficients</i>	<i>Standard Error</i>	<i>t Stat</i>	<i>P-value</i>	<i>Lower 95%</i>	<i>Upper 95%</i>	<i>Lower 95.0%</i>	<i>Upper 95.0%</i>
Intercept	0.000	#N/A	#N/A	#N/A	#N/A	#N/A	#N/A	#N/A
X Variable 1	0.286	0.022	13.206	0.000	0.240	0.332	0.240	0.332

Mann-Whitney-Wilcoxon Test

n_1	16
n_2	16
Observed T	344.000
Expected T	264.000
Std. Dev. T	26.533
Test Statistic	3.015
p-Value (lower t	0.998716
p-Value (upper	0.001
p-Value (two ta	0.003
Reject H_0 , if p-Value < 0.05	
Significant Diff? Yes	
H_0 : Influent and Effluent Concentration is Same	
H_a : Influent and Effluent Concentration is Differ	

30~60 μm Solids Influent vs. Effluent Probability in 95% Confidence Interval

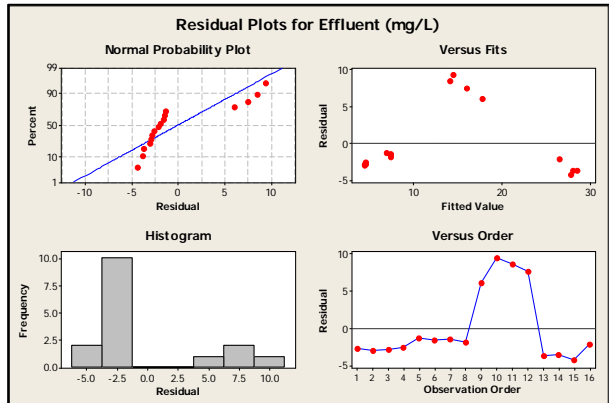
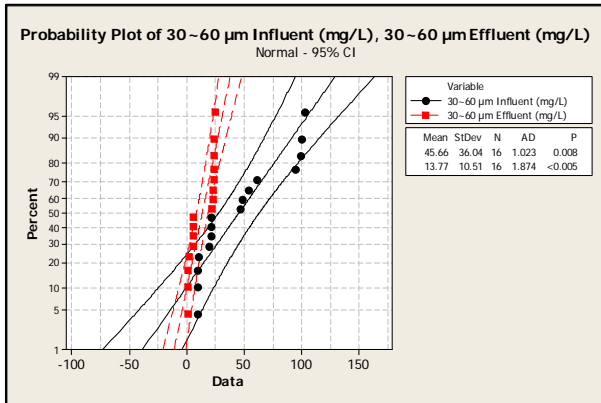
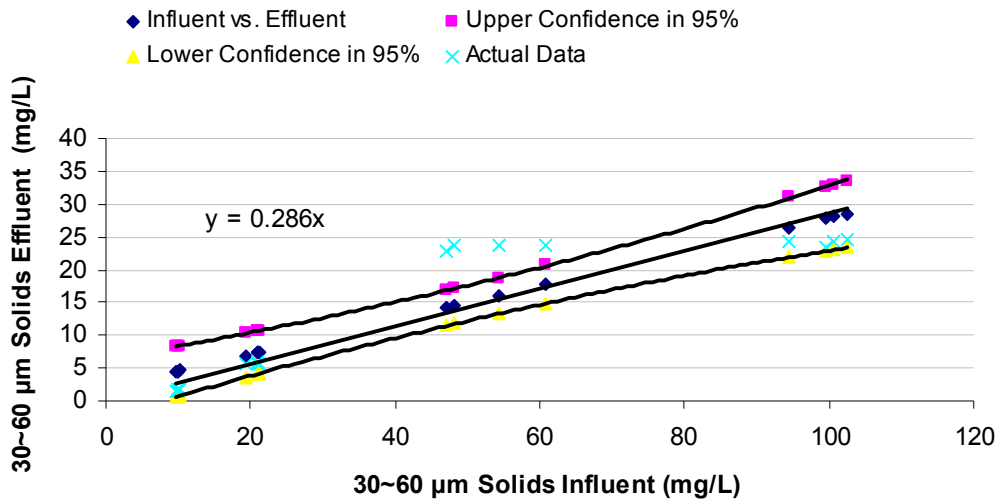

Appendix G.57: Mixed Media 150gpm 60-120 μ m Probability Analysis Detail

SUMMARY OUTPUT

<i>Regression Statistics</i>	
Multiple R	0.866
R Square	0.751
Adjusted R Square	0.684
Standard Error	1.310
Observations	16.000

ANOVA					
	<i>df</i>	<i>SS</i>	<i>MS</i>	<i>F</i>	<i>Significance F</i>
Regression	1.000	77.443	77.443	45.155	0.000
Residual	15.000	25.725	1.715		
Total	16.000	103.168			

	<i>Coefficients</i>	<i>Standard Error</i>	<i>t Stat</i>	<i>P-value</i>	<i>Lower 95%</i>	<i>Upper 95%</i>	<i>Lower 95.0%</i>	<i>Upper 95.0%</i>
Intercept	0.000	#N/A	#N/A	#N/A	#N/A	#N/A	#N/A	#N/A
X Variable 1	0.314	0.047	6.720	0.000	0.214	0.414	0.214	0.414

Mann-Whitney-Wilcoxon Test

n_1	16
n_2	16
Observed T	337.000
Expected T	264.000
Std. Dev. T	26.533
Test Statistic	2.751
p-Value (lower	0.997032
p-Value (upper	0.003
p-Value (two ta	0.006
Reject H_0 , if p-Value < 0.05	
Significant Diff? Yes	
H_0 : Influent and Effluent Concentration is Same	
H_a : Influent and Effluent Concentration is Differ	

60~120 µm Solids Influent vs. Effluent Probability in 95% Confidence Interval

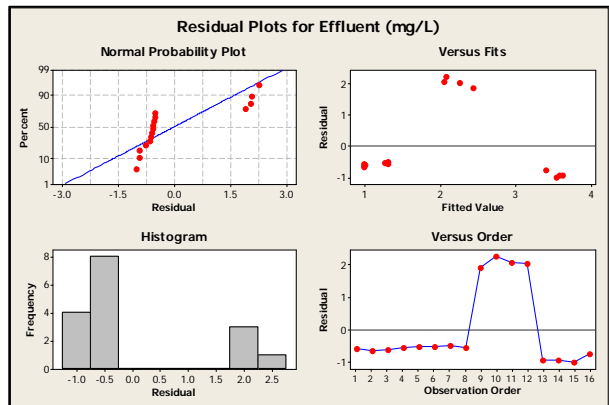
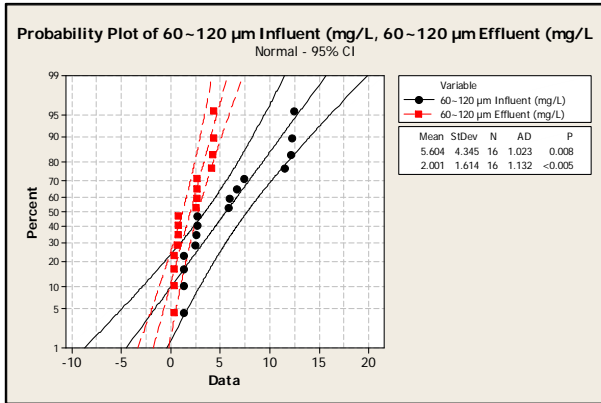
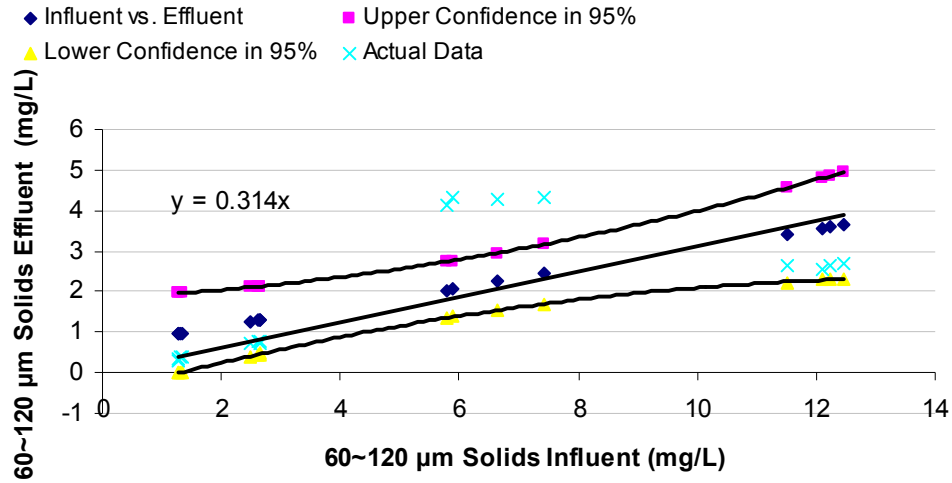

Appendix G.58: Mixed Media 150gpm 120-250 μm Probability Analysis Detail

SUMMARY OUTPUT

<i>Regression Statistics</i>	
Multiple R	0.724
R Square	0.525
Adjusted R Square	0.491
Standard Error	0.035
Observations	16.000

ANOVA						
	<i>df</i>	<i>SS</i>	<i>MS</i>	<i>F</i>	<i>Significance F</i>	
Regression	1.000	0.019	0.019	15.457	0.002	
Residual	14.000	0.017	0.001			
Total	15.000	0.036				

	<i>Coefficients</i>	<i>Standard Error</i>	<i>t Stat</i>	<i>P-value</i>	<i>Lower 95%</i>	<i>Upper 95%</i>	<i>Lower 95.0%</i>	<i>Upper 95.0%</i>
Intercept	0.040	0.014	2.791	0.014	0.009	0.071	0.009	0.071
X Variable 1	0.016	0.004	3.932	0.002	0.007	0.024	0.007	0.024

Mann-Whitney-Wilcoxon Test

n_1	16
n_2	16
Observed T	392.000
Expected T	264.000
Std. Dev. T	26.533
Test Statistic	4.824
p-Value (lower)	0.999999
p-Value (upper)	0.000
p-Value (two ta	0.000
Reject H_0 , if p-Value < 0.05	
Significant Diff? Yes	
H_0 : Influent and Effluent Concentration is Same	
H_a : Influent and Effluent Concentration is Differ	

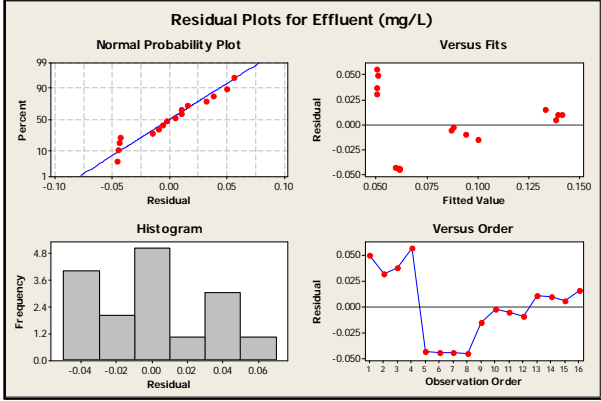
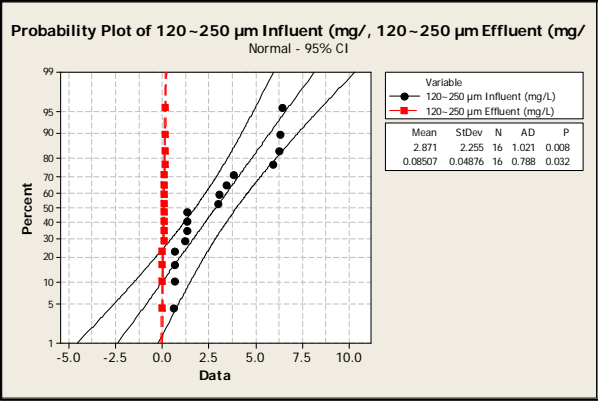
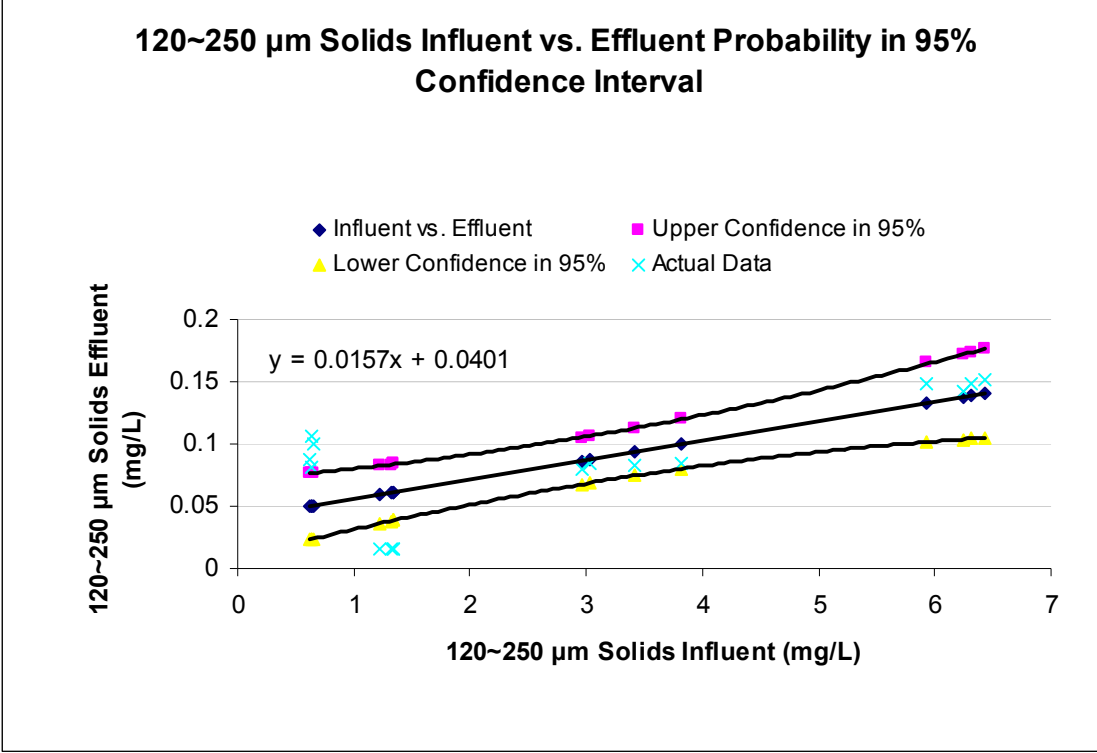

Appendix G.59: Mixed Media 150gpm 250-1180 μm Probability Analysis Detail

SUMMARY OUTPUT

<i>Regression Statistics</i>	
Multiple R	1
R Square	1
Adjusted R Square	1
Standard Error	0
Observations	16

ANOVA

	<i>df</i>	<i>SS</i>	<i>MS</i>	<i>F</i>	<i>Significance F</i>
Regression	1	0	0	#NUM!	#NUM!
Residual	14	0	0		
Total	15	0			

	<i>Coefficients</i>	<i>Standard Error</i>	<i>t Stat</i>	<i>P-value</i>	<i>Lower 95%</i>	<i>Upper 95%</i>	<i>Lower 90.0%</i>	<i>Upper 90.0%</i>
Intercept	0	0	65535	#NUM!	0	0	0	0
X Variable 1	0	0	65535	#NUM!	0	0	0	0

Mann-Whitney-Wilcoxon Test

n_1	16
n_2	16
Observed T	392.000
Expected T	264.000
Std. Dev. T	26.533
Test Statistic	4.824
p-Value (lower	0.999999
p-Value (upper	0.000
p-Value (two ta	0.000
Reject H_0 , if p-Value < 0.05	
Significant Diff? Yes	
H_0 : Influent and Effluent Concentration is Same	
H_a : Influent and Effluent Concentration is Differ	

250~1180 μm Solids Influent vs. Effluent Probability in 95% Confidence Interval

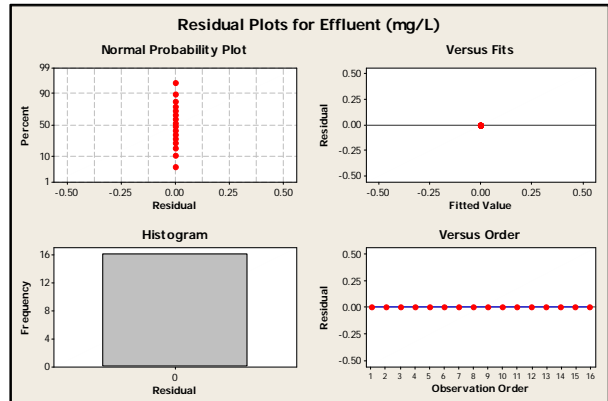
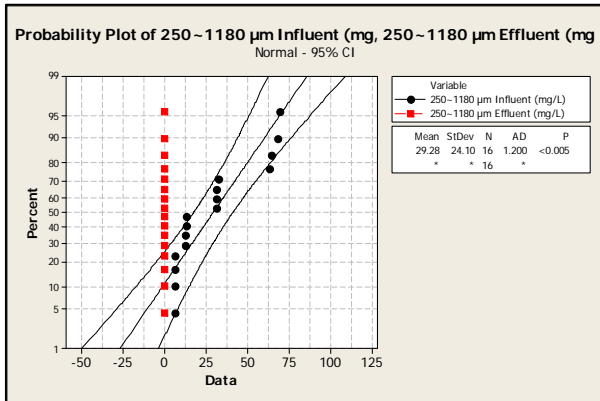
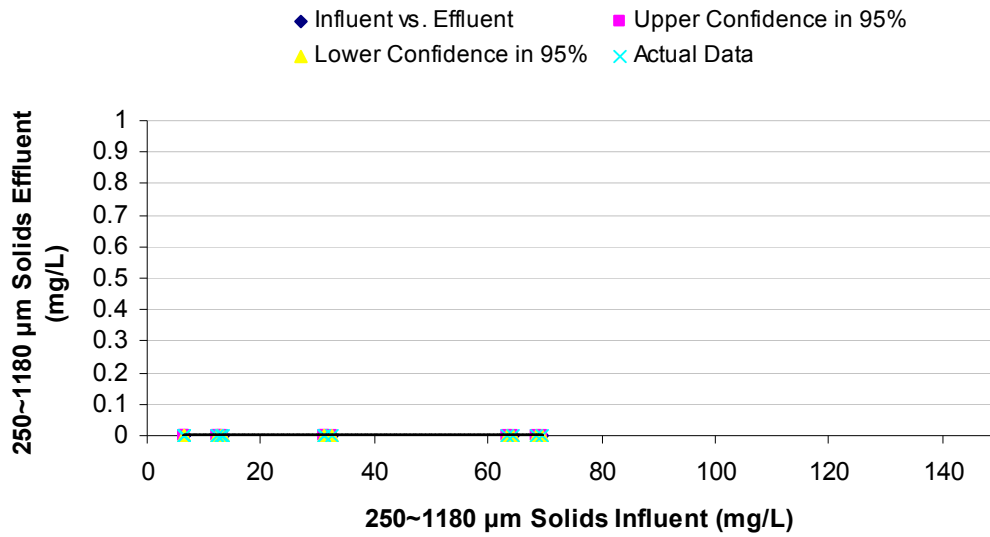

Appendix G.60: Mixed Media 150gpm >1180 μ m Probability Analysis Detail

SUMMARY OUTPUT

<i>Regression Statistics</i>	
Multiple R	1
R Square	1
Adjusted R Square	1
Standard Error	0
Observations	16

ANOVA

	<i>df</i>	<i>SS</i>	<i>MS</i>	<i>F</i>	<i>Significance F</i>
Regression	1	0	0	#NUM!	#NUM!
Residual	14	0	0		
Total	15	0			

	<i>Coefficients</i>	<i>Standard Error</i>	<i>t Stat</i>	<i>P-value</i>	<i>Lower 95%</i>	<i>Upper 95%</i>	<i>Lower 90.0%</i>	<i>Upper 90.0%</i>
Intercept	0	0	65535	#NUM!	0	0	0	0
X Variable 1	0	0	65535	#NUM!	0	0	0	0

Mann-Whitney-Wilcoxon Test

n_1	16
n_2	16
Observed T	392.000
Expected T	264.000
Std. Dev. T	26.533
Test Statistic	4.824
p-Value (lower tail)	0.999999
p-Value (upper tail)	0.000
p-Value (two-tailed)	0.000
Reject H_0 , if p-Value < 0.05	
Significant Diff? Yes	
H_0 : Influent and Effluent Concentration is Same	
H_a : Influent and Effluent Concentration is Differ	

>1180 μm Solids Influent vs. Effluent Probability in 95% Confidence Interval

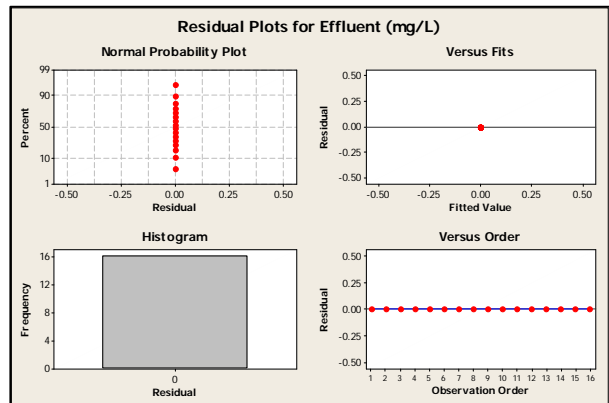
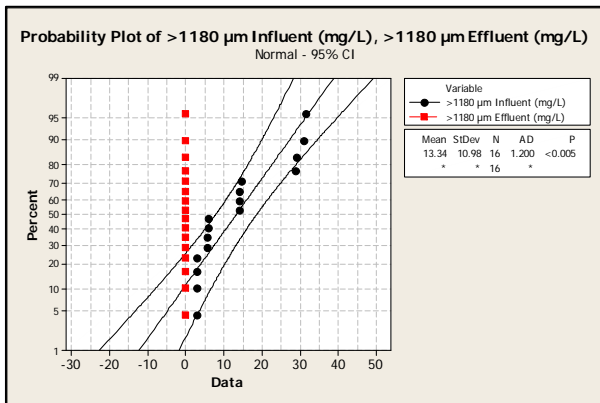
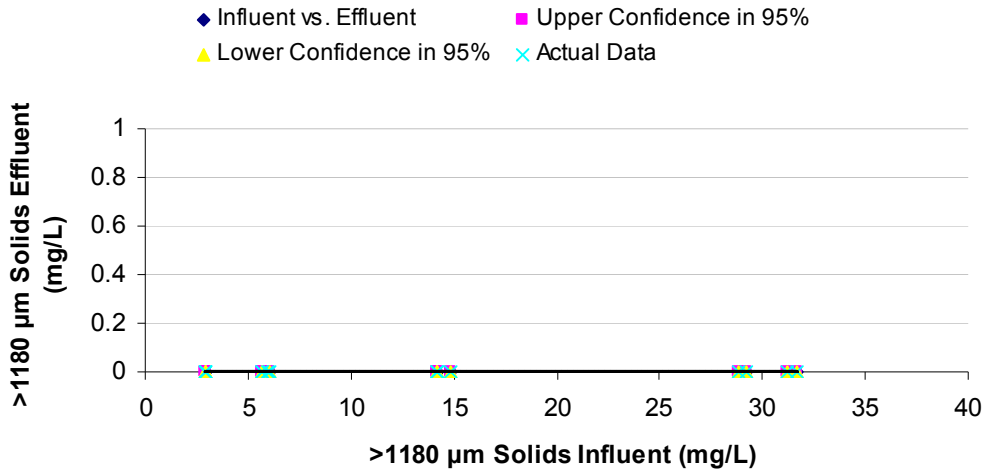

Appendix H.1: July 16, 2010 Rain Event Analysis

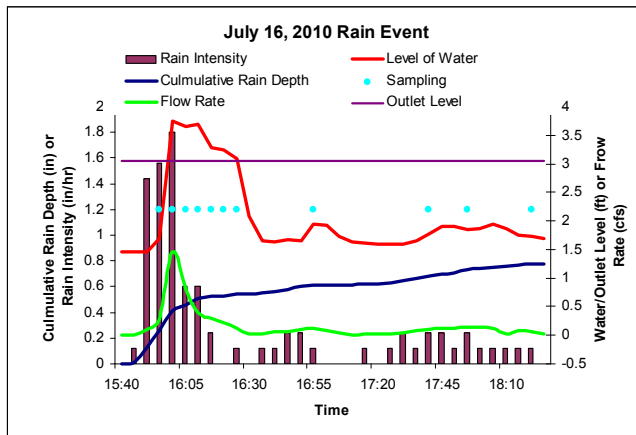

Site Information			
Site Name:	Bama Belle Parking Deck		
Site Location:	N(33°12'50") W(87°34'17")		
Drainage Area (ac):	0.9		
Percent Impervious (%):	67.8		
Runoff Curve Number	84.1		
Rational Number	0.6		
Storm Information – July 16, 2010 Storm			
	Goal	Value	QA note
Precipitation Total (in):	≥0.1	0.78	
Precipitation Duration (hr):	≥1	2.8	
Average Intensity (in/hr):	NA	0.28	
Peak Rain Intensity (in/hr):	NA	1.8	
Storm Volume (gal):	NA	11984	(0.498 in)
Maximum Discharge (cfs):	NA	1.5	
Ave Discharge Rate (cfs):	NA	0.16	
Peak to Ave Discharge Ratio:	NA	9.1	
Dry Period (hr):	≥6	≥6	
Estimated Rational Coefficient	NA	0.9	
Volumetric Runoff Coefficient	NA	0.6	

Sampling Information						
	Goal	IN	QA	Out	QA	note
Aliquots:	≥5	11		11		
% Storm:	≥75	100		100		
	Value					
Total Bypass Volume (gal):	223					
% Bypassed to Total (%):	1.9					

Analysis Information						
EMC Concentration (mg/L, CFU/100mL, #)						
	IN	note	OUT	note	MDL	note
						% Conc. Reduction
TSS	148.6		14.7		NA	90.1
SSC	-		-		NA	-
TDS	332.9		37.9		NA	88.6
Conductivity	448.0		205.0		0 to 199,900 μS	54.2
PH	6.57		6.87		-2.00 to 19.99	-4.6
Turbidity	55.8		7.5		0 to 4000 NTU	86.5
Total COD	120		77		0 to 150 mg/L	35.8
Dissolved COD	65		34		0 to 150 mg/L	47.7
Total P	2.19		2.17		0.00 to 3.50 mg/L	0.9
Dissolved P	1.65		0.95		0.00 to 5.00 mg/L	42.4
Ammonia	0.08		0.08		0 to 2.5 mg/L	0
Nitrate	1.4		0.7		0 to 5.0 mg/L	50.0
Total N	2		1		0 to 2.5 mg/L	50.0
Dissolved N	1		0		0 to 2.5 mg/L	100
Total Zn	0.09		BDL		0.02 mg/L	>77.8
Dissolved Zn	BDL		BDL		0.02 mg/L	-
Total Cd	BDL		BDL		0.005 mg/L	-
Dissolved Cd	BDL		BDL		0.005 mg/L	-
Total Cr	BDL		BDL		0.02 mg/L	-
Dissolved Cr	BDL		BDL		0.02 mg/L	-
Total Cu	0.02		BDL		0.02 mg/L	>0
Dissolved Cu	BDL		BDL		0.02 mg/L	-
Total Pb	0.013		BDL		0.005 mg/L	>61.5
Dissolved Pb	BDL		BDL		0.005 mg/L	-
E-Coli	-		-		10-24196	-
Enterococci	-		-		10-24196	-

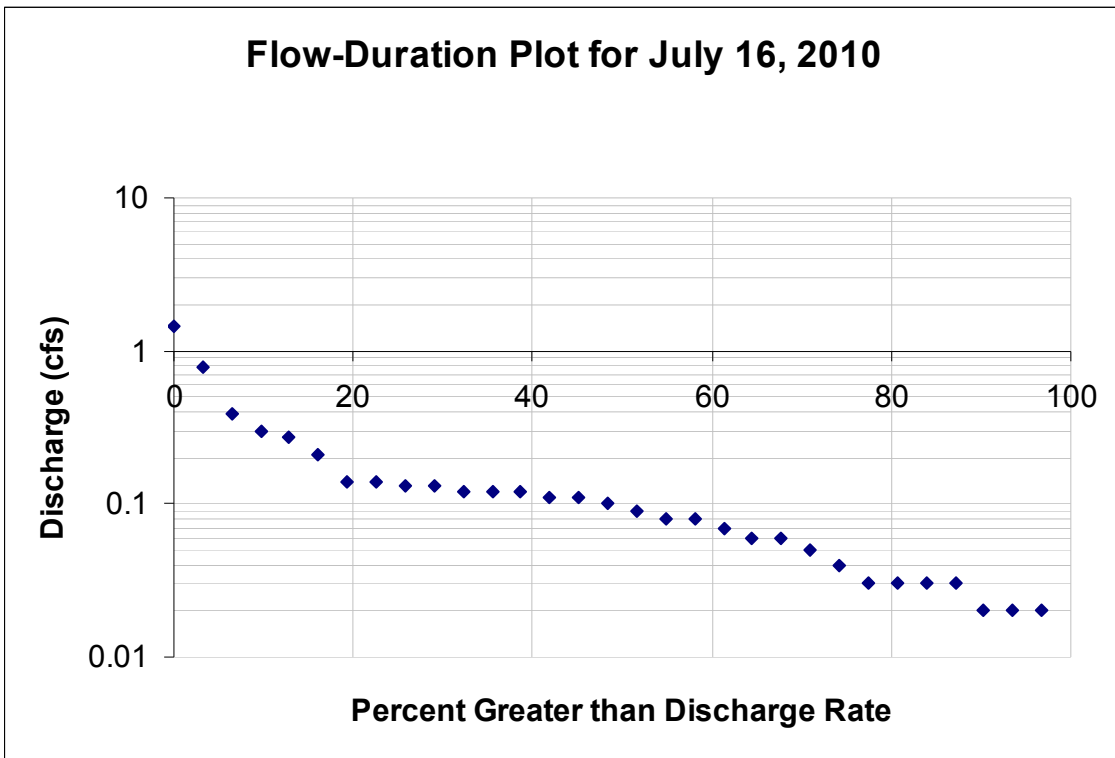
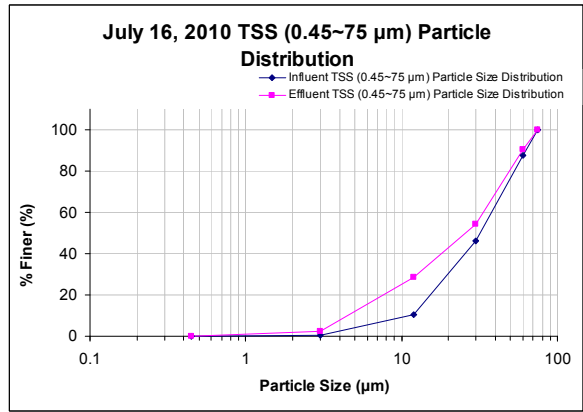
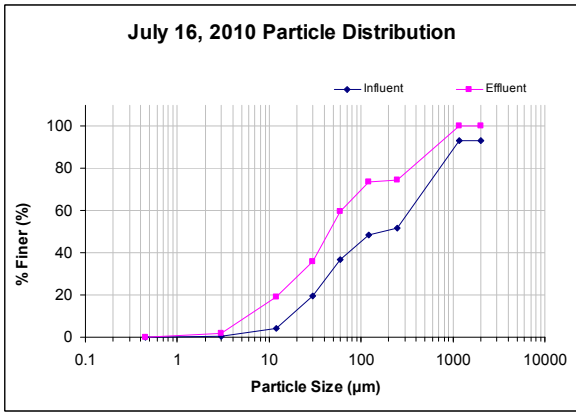

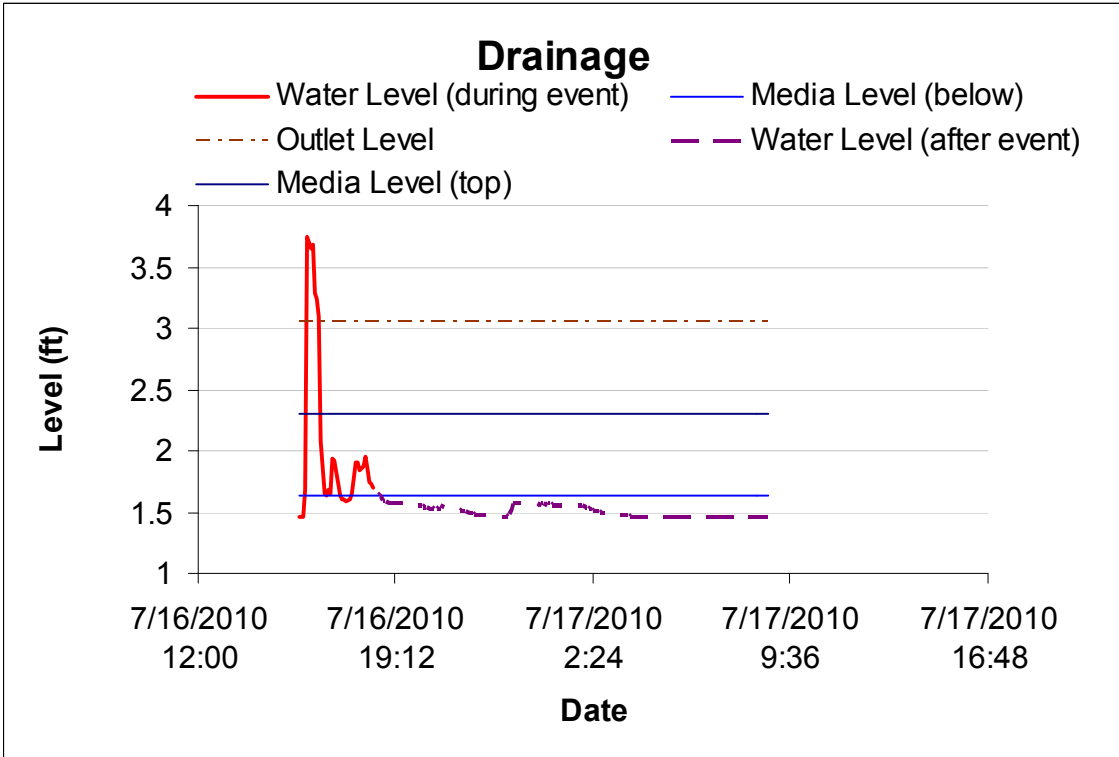
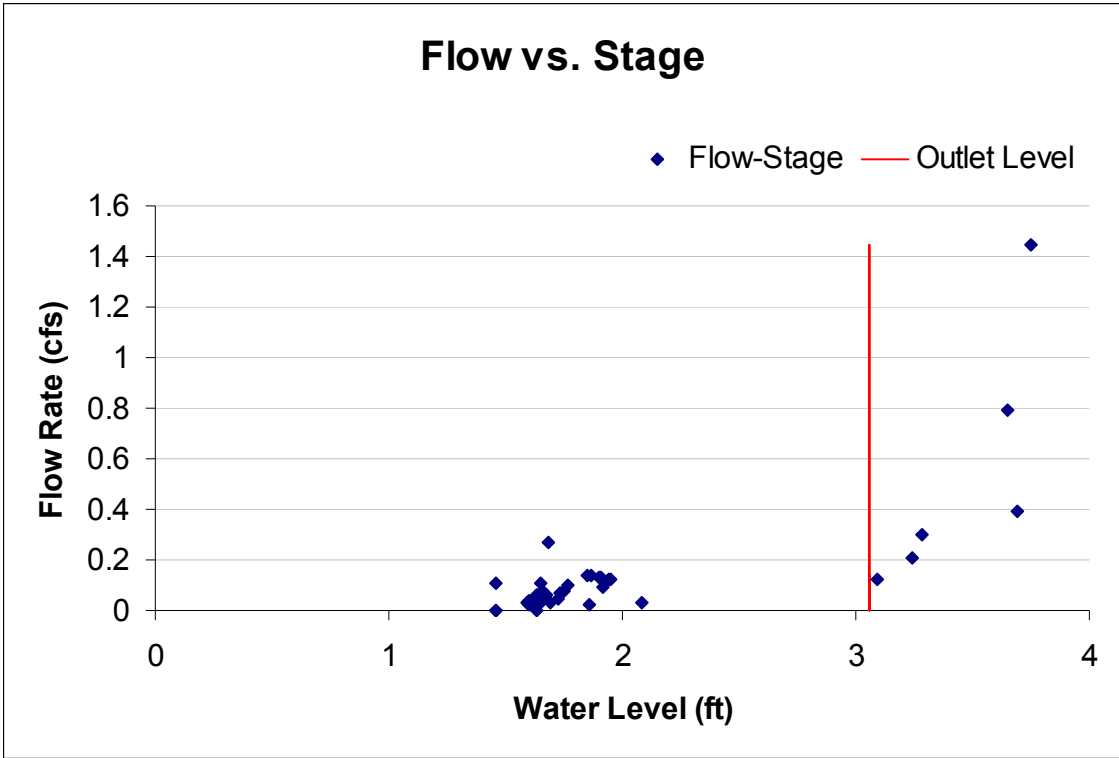

Appendix H.2: August 14, 2010 Rain Event Analysis

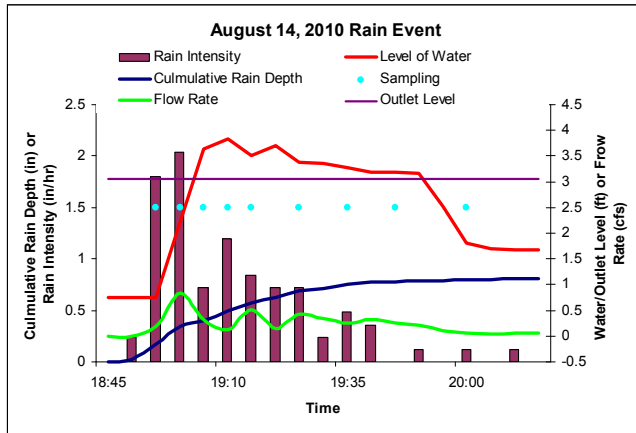

Site Information			
Site Name:	Bama Belle Parking Deck		
Site Location:	N(33°12'50") W(87°34'17")		
Drainage Area (ac):	0.9		
Percent Impervious (%):	67.8		
Runoff Curve Number	84.1		
Rational Number	0.6		
Storm Information – August 14, 2010 Storm			
	Goal	Value	QA note
Precipitation Total (in):	≥0.1	0.81	
Precipitation Duration (hr):	≥1	1.6	
Average Intensity (in/hr):	NA	0.51	
Peak Rain Intensity (in/hr):	NA	2.0	
Storm Volume (gal):	NA	9470	(0.393 in)
Maximum Discharge (cfs):	NA	0.8	
Ave Discharge Rate (cfs):	NA	0.22	
Peak to Ave Discharge Ratio:	NA	3.8	
Dry Period (hr):	≥6	≥6	
Estimated Rational Coefficient	NA	0.5	
Volumetric Runoff Coefficient	NA	0.5	

Sampling Information						
	Goal	IN	QA	Out	QA	note
Aliquots:	≥5	9		9		
% Storm:	≥75	100		100		
Value						
Total Bypass Volume (gal):	345					
% Bypassed to Total (%):	3.6					

Analysis Information							
EMC Concentration (mg/L, CFU/100mL, #)							
	IN	note	OUT	note	MDL	note	
	% Conc. Reduction						
TSS	140.6		7.6		NA		94.6
SSC	-		-		NA		-
TDS	167.1		25.7		NA		84.6
Conductivity	160.0		95.0		0 to 199,900 μS		40.6
PH	6.60		6.89		-2.00 to 19.99		-4.4
Turbidity	30.2		8.7		0 to 4000 NTU		71.2
Total COD	78		50		0 to 150 mg/L		35.9
Dissolved COD	63		57		0 to 150 mg/L		9.5
Total P	1.24		1.14		0.00 to 3.50 mg/L		8.1
Dissolved P	0.69		0.54		0.00 to 5.00 mg/L		21.7
Ammonia	0.14		0.12		0 to 2.5 mg/L		14.3
Nitrate	1.8		0.7		0 to 5.0 mg/L		61.1
Total N	5		1		0 to 2.5 mg/L		80.0
Dissolved N	2		1		0 to 2.5 mg/L		50.0
Total Zn	0.1		BDL		0.02 mg/L		-
Dissolved Zn	0.07		0.03		0.02 mg/L		57.1
Total Cd	BDL		BDL		0.005 mg/L		-
Dissolved Cd	BDL		BDL		0.005 mg/L		-
Total Cr	BDL		BDL		0.02 mg/L		-
Dissolved Cr	BDL		BDL		0.02 mg/L		-
Total Cu	0.02		BDL		0.02 mg/L		-
Dissolved Cu	0.02		BDL		0.02 mg/L		-
Total Pb	0.011		BDL		0.005 mg/L		-
Dissolved Pb	BDL		BDL		0.005 mg/L		-
E-Coli	24190		10110		10-24196		58.2
Enterococci	10110		1660		10-24196		83.6

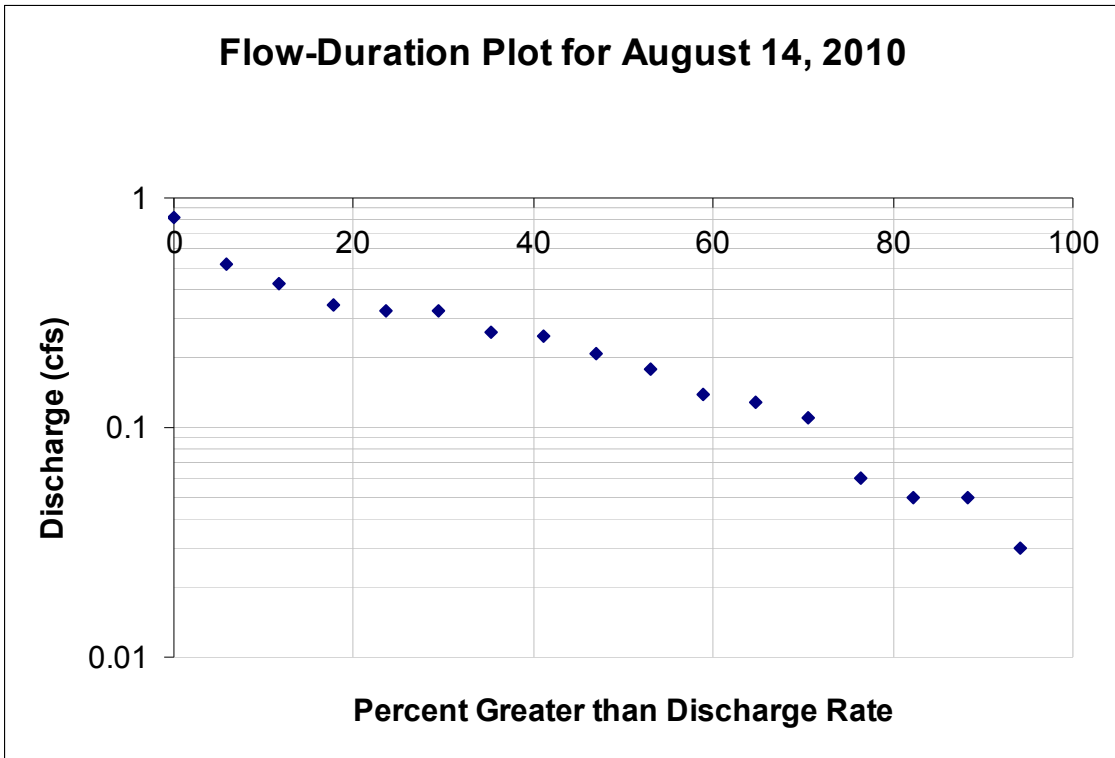
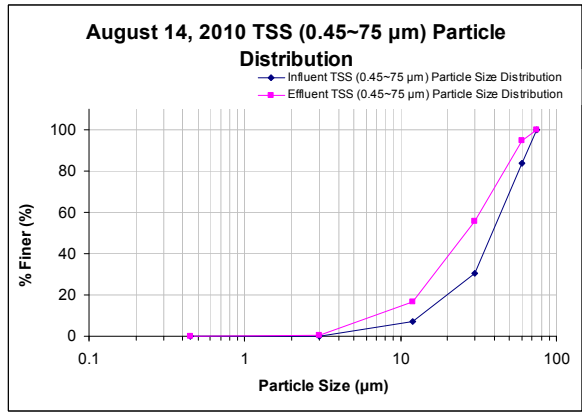
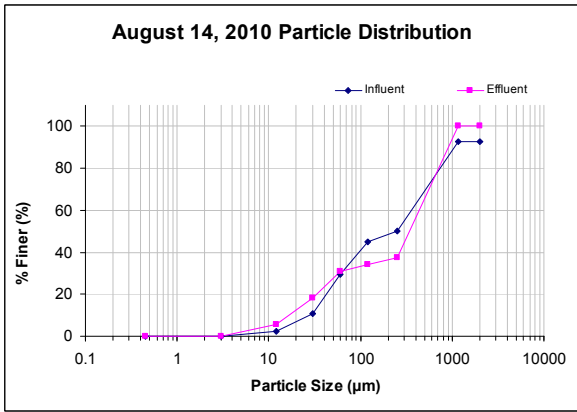

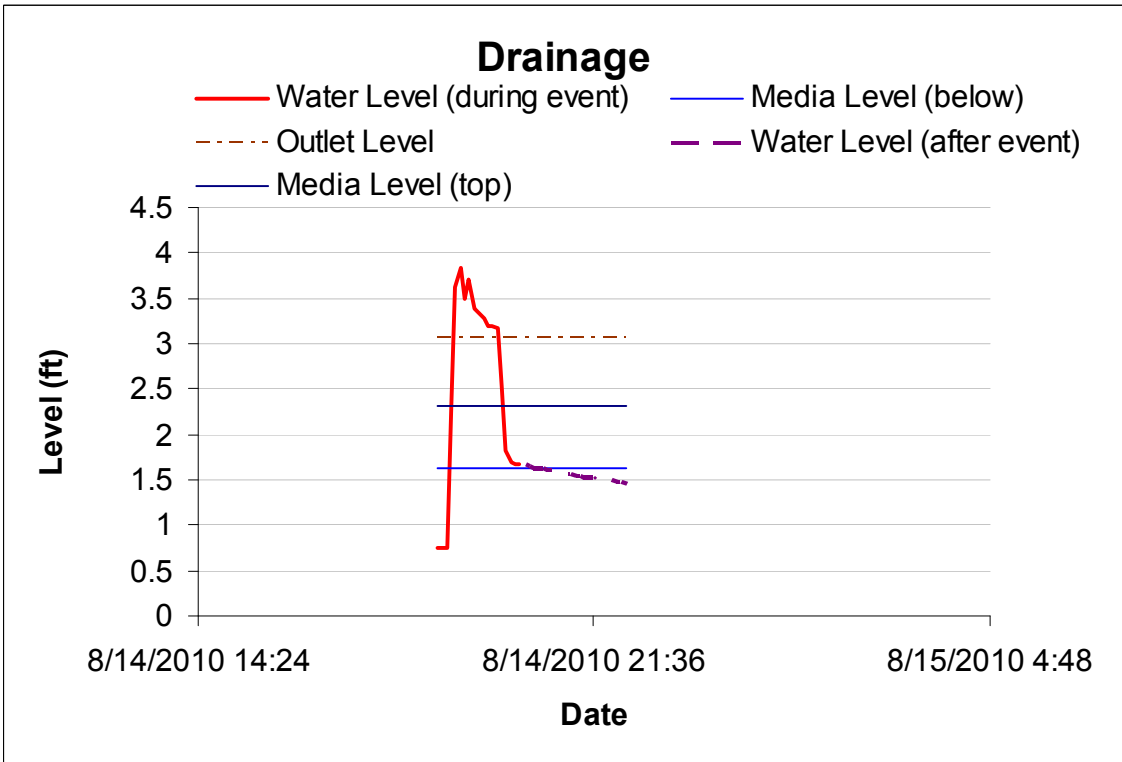
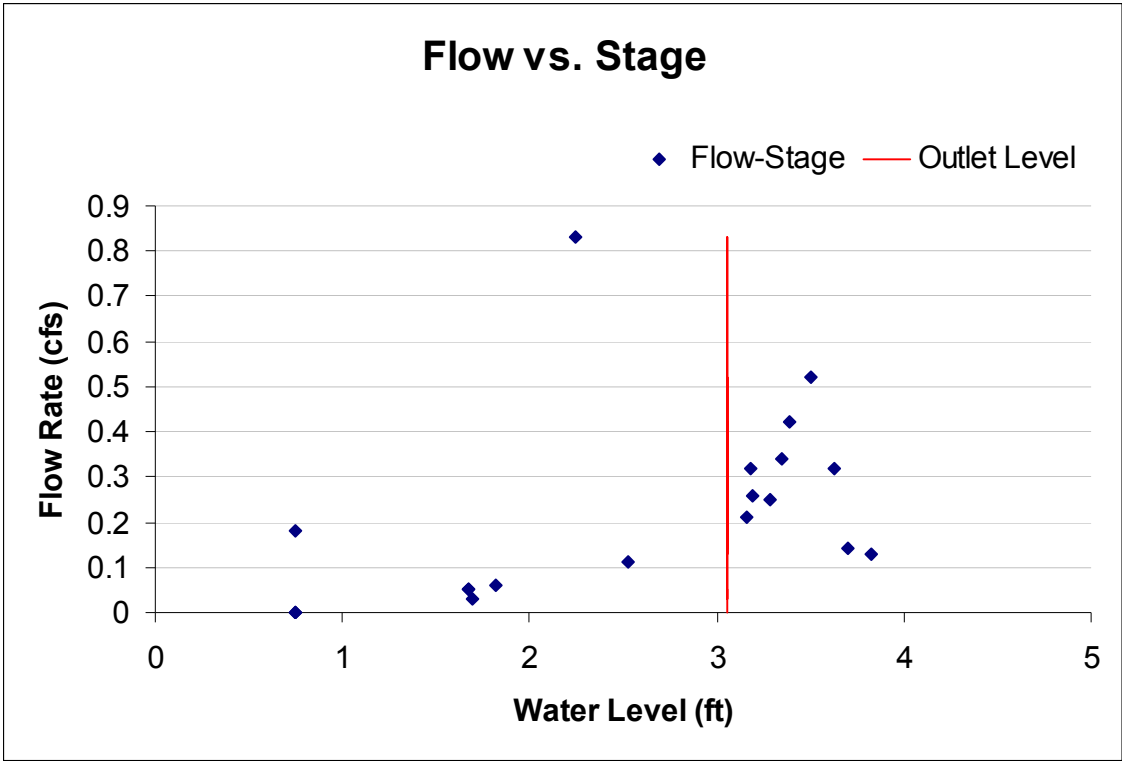

Appendix H.3: August 28, 2010 Rain Event Analysis

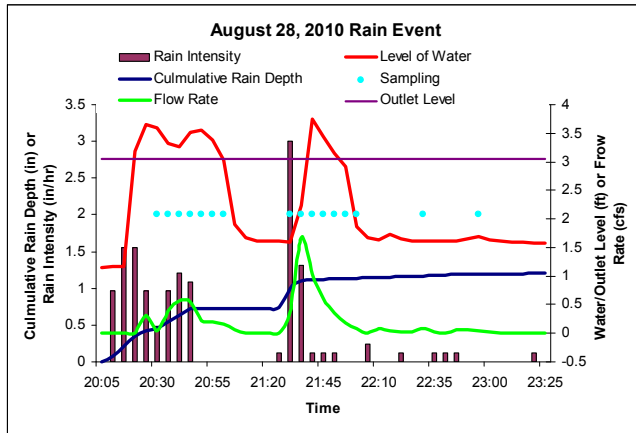

Site Information			
Site Name:	Bama Belle Parking Deck		
Site Location:	N(33°12'50") W(87°34'17")		
Drainage Area (ac):	0.9		
Percent Impervious (%):	67.8		
Runoff Curve Number	84.1		
Rational Number	0.6		
Storm Information – August 28, 2010 Storm			
	Goal	Value	QA note
Precipitation Total (in):	≥0.1	1.2	
Precipitation Duration (hr):	≥1	3.4	
Average Intensity (in/hr):	NA	0.35	
Peak Rain Intensity (in/hr):	NA	3.0	
Storm Volume (gal):	NA	16427	(0.683 in)
Maximum Discharge (cfs):	NA	1.7	
Ave Discharge Rate (cfs):	NA	0.18	
Peak to Ave Discharge Ratio:	NA	9.4	
Dry Period (hr):	≥6	≥6	
Estimated Rational Coefficient	NA	0.6	
Volumetric Runoff Coefficient	NA	0.6	

Sampling Information					
	Goal	IN	QA	Out	QA note
Aliquots:	≥5	16		16	
% Storm:	≥75	100		100	
Value					
Total Bypass Volume (gal):	395				
% Bypassed to Total (%):	2.4				

Analysis Information							
EMC Concentration (mg/L, CFU/100mL, #)							
	IN	note	OUT	note	MDL	note	% Conc. Reduction
TSS	85.3		4.8		NA		94.4
SSC	-		-		NA		-
TDS	120.0		85.7		NA		28.6
Conductivity	83.0		74.4		0 to 199,900 μS		54.2
PH	6.60		6.81		-2.00 to 19.99		-3.2
Turbidity	4.9		4.1		0 to 4000 NTU		16.3
Total COD	10		7		0 to 150 mg/L		30.0
Dissolved COD	7		3		0 to 150 mg/L		57.1
Total P	1.20		0.98		0.00 to 3.50 mg/L		18.3
Dissolved P	0.68		0.54		0.00 to 5.00 mg/L		20.6
Ammonia	0.08		0.04		0 to 2.5 mg/L		50.0
Nitrate	0.9		0.7		0 to 5.0 mg/L		22.2
Total N	3		1		0 to 2.5 mg/L		66.7
Dissolved N	2		1		0 to 2.5 mg/L		50.0
Total Zn	BDL		BDL		0.02 mg/L		-
Dissolved Zn	BDL		BDL		0.02 mg/L		-
Total Cd	BDL		BDL		0.005 mg/L		-
Dissolved Cd	BDL		BDL		0.005 mg/L		-
Total Cr	BDL		BDL		0.02 mg/L		-
Dissolved Cr	BDL		BDL		0.02 mg/L		-
Total Cu	BDL		BDL		0.02 mg/L		-
Dissolved Cu	BDL		BDL		0.02 mg/L		-
Total Pb	BDL		BDL		0.005 mg/L		-
Dissolved Pb	BDL		BDL		0.005 mg/L		-
E-Coli	4170		840		10-24196		79.9
Enterococci	6830		1660		10-24196		75.7

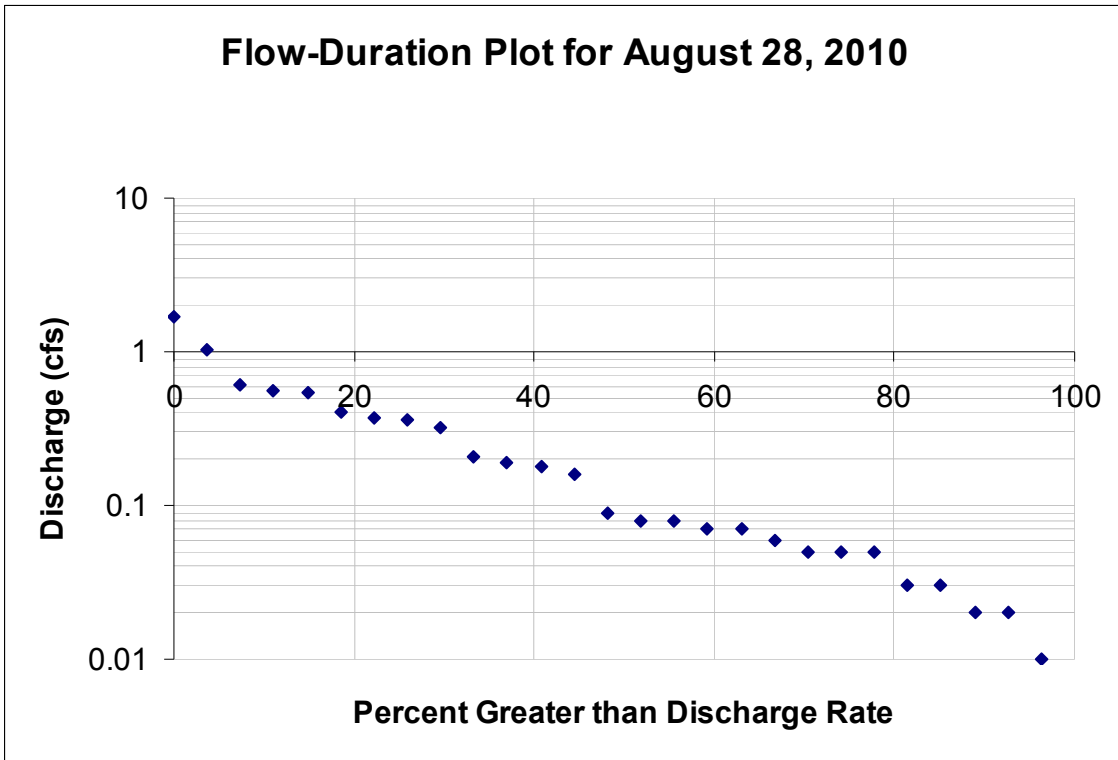
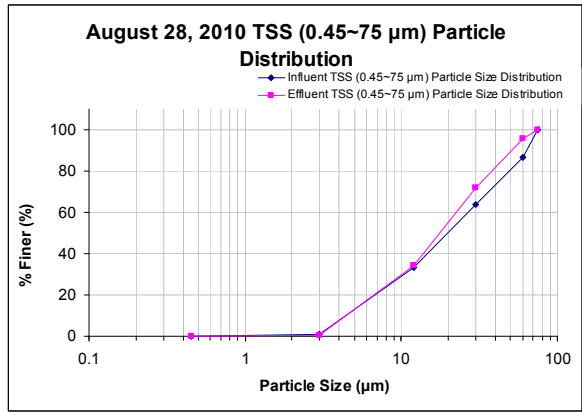
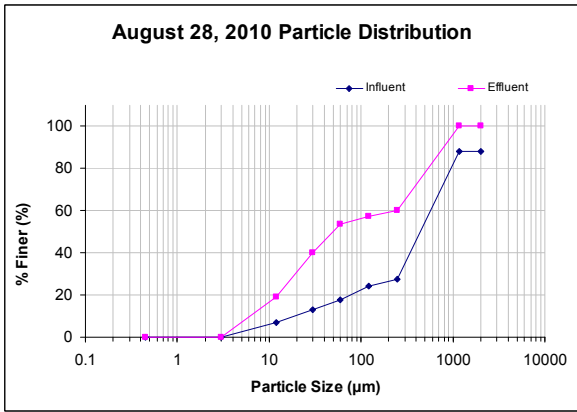

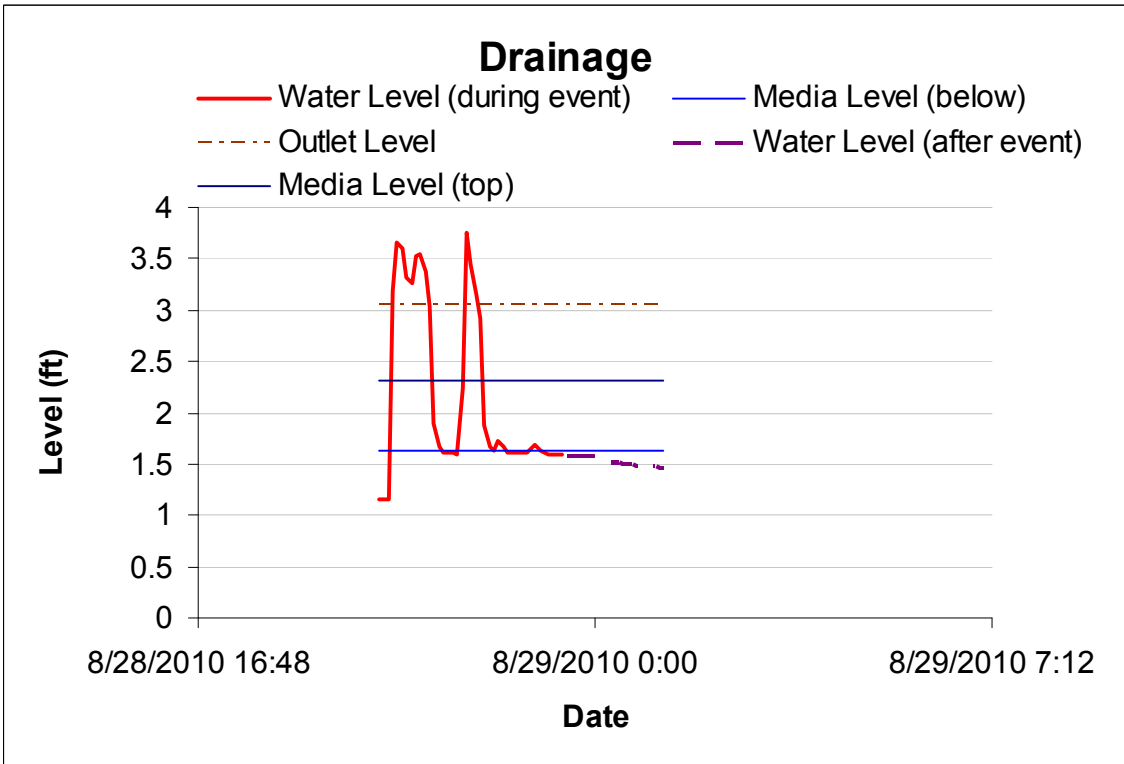
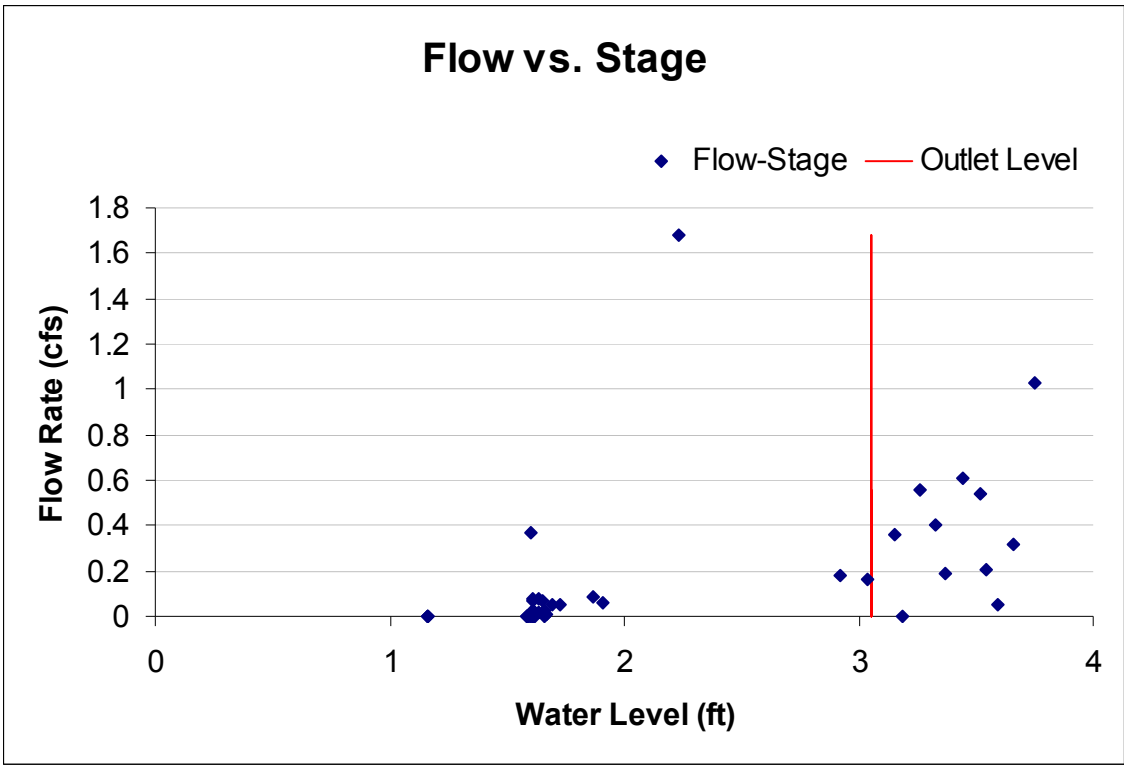

Appendix H.4: September 26, 2010 Rain Event Analysis

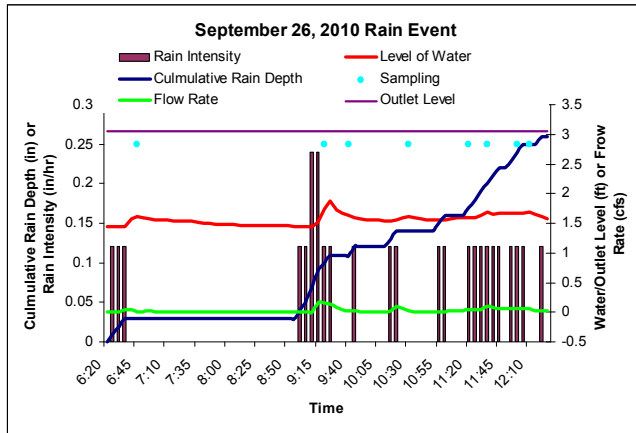

Site Information			
Site Name:	Bama Belle Parking Deck		
Site Location:	N(33°12'50") W(87°34'17")		
Drainage Area (ac):	0.9		
Percent Impervious (%):	67.8		
Runoff Curve Number	84.1		
Rational Number	0.6		
Storm Information – September 26, 2010 Storm			
	Goal	Value	QA note
Precipitation Total (in):	≥0.1	0.26	
Precipitation Duration (hr):	≥1	6.2	
Average Intensity (in/hr):	NA	0.04	
Peak Rain Intensity (in/hr):	NA	0.24	
Storm Volume (gal):	NA	4152	(0.173 in)
Maximum Discharge (cfs):	NA	0.15	
Ave Discharge Rate (cfs):	NA	0.03	
Peak to Ave Discharge Ratio:	NA	5.0	
Dry Period (hr):	≥6	≥6	
Estimated Rational Coefficient	NA	0.7	
Volumetric Runoff Coefficient	NA	0.7	

Sampling Information						
	Goal	IN	QA	Out	QA	note
Aliquots:	≥5	8		8		
% Storm:	≥75	100		100		
	Value					
Total Bypass Volume (gal):	0					
% Bypassed to Total (%):	0					

Analysis Information							
EMC Concentration (mg/L, CFU/100mL, #)							
	IN	note	OUT	note	MDL	note	% Conc. Reduction
TSS	53.6		10.0		NA		81.3
SSC	55.0		8.0		NA		85.5
TDS	91.8		79.2		NA		13.7
Conductivity	106.3		96.0		0 to 199,900 μS		9.7
PH	6.58		6.83		-2.00 to 19.99		-3.8
Turbidity	21.2		9.5		0 to 4000 NTU		55.4
Total COD	72		49		0 to 150 mg/L		31.9
Dissolved COD	28		26		0 to 150 mg/L		7.1
Total P	1.15		0.86		0.00 to 3.50 mg/L		25.2
Dissolved P	0.57		0.53		0.00 to 5.00 mg/L		7.0
Ammonia	0.08		0.01		0 to 2.5 mg/L		87.5
Nitrate	0.8		0.7		0 to 5.0 mg/L		12.5
Total N	3		2		0 to 2.5 mg/L		33.3
Dissolved N	2		1		0 to 2.5 mg/L		50
Total Zn	0.09		BDL		0.02 mg/L		>77.8
Dissolved Zn	0.08		BDL		0.02 mg/L		>75.0
Total Cd	BDL		BDL		0.005 mg/L		-
Dissolved Cd	BDL		BDL		0.005 mg/L		-
Total Cr	BDL		BDL		0.02 mg/L		-
Dissolved Cr	BDL		BDL		0.02 mg/L		-
Total Cu	0.21		0.06		0.02 mg/L		71.4
Dissolved Cu	0.08		0.05		0.02 mg/L		37.5
Total Pb	BDL		BDL		0.005 mg/L		-
Dissolved Pb	BDL		BDL		0.005 mg/L		-
E-Coli	4170		840		10-24196		79.9
Enterococci	2230		1180		10-24196		47.1

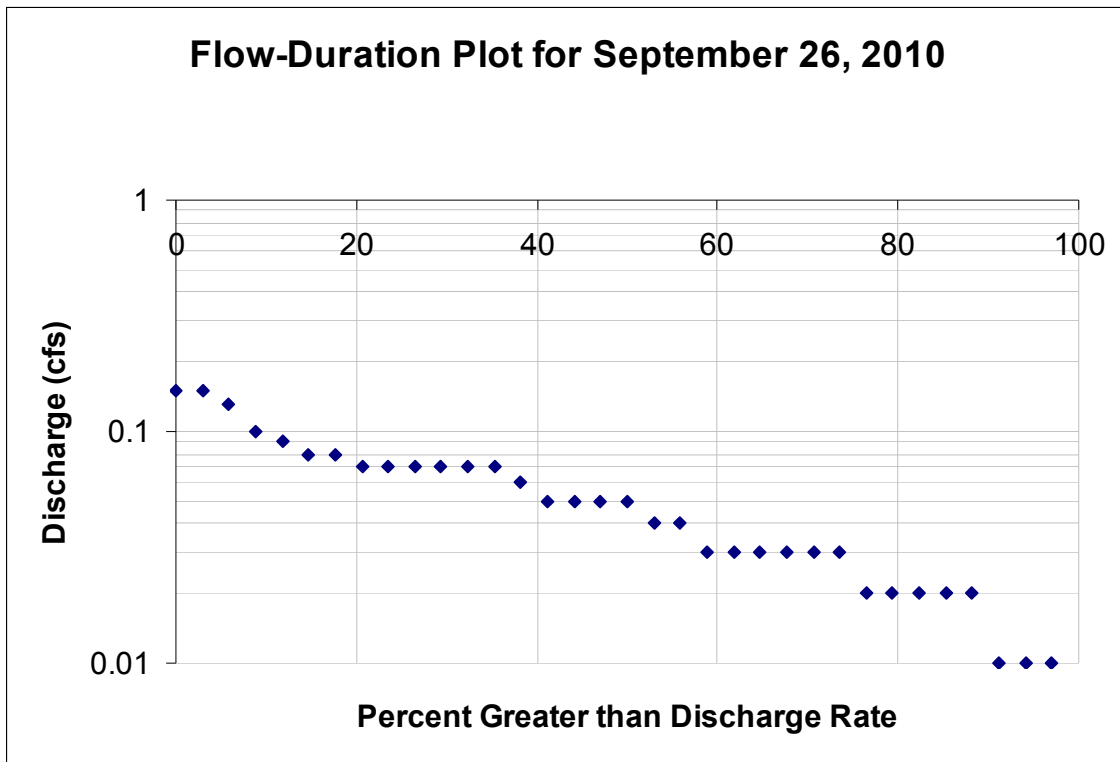
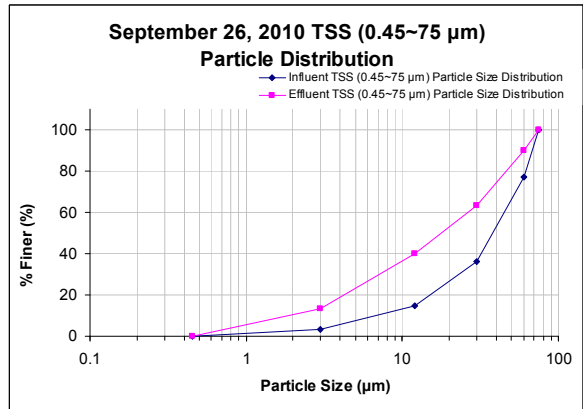
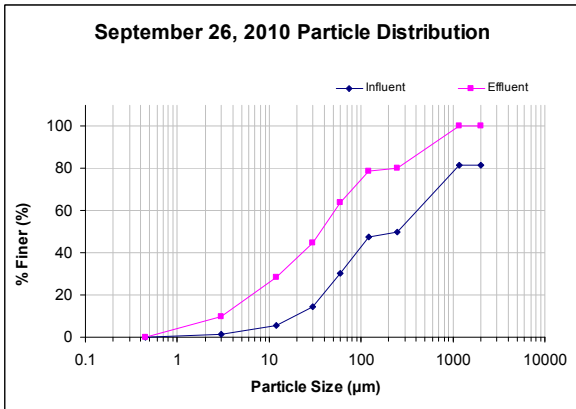

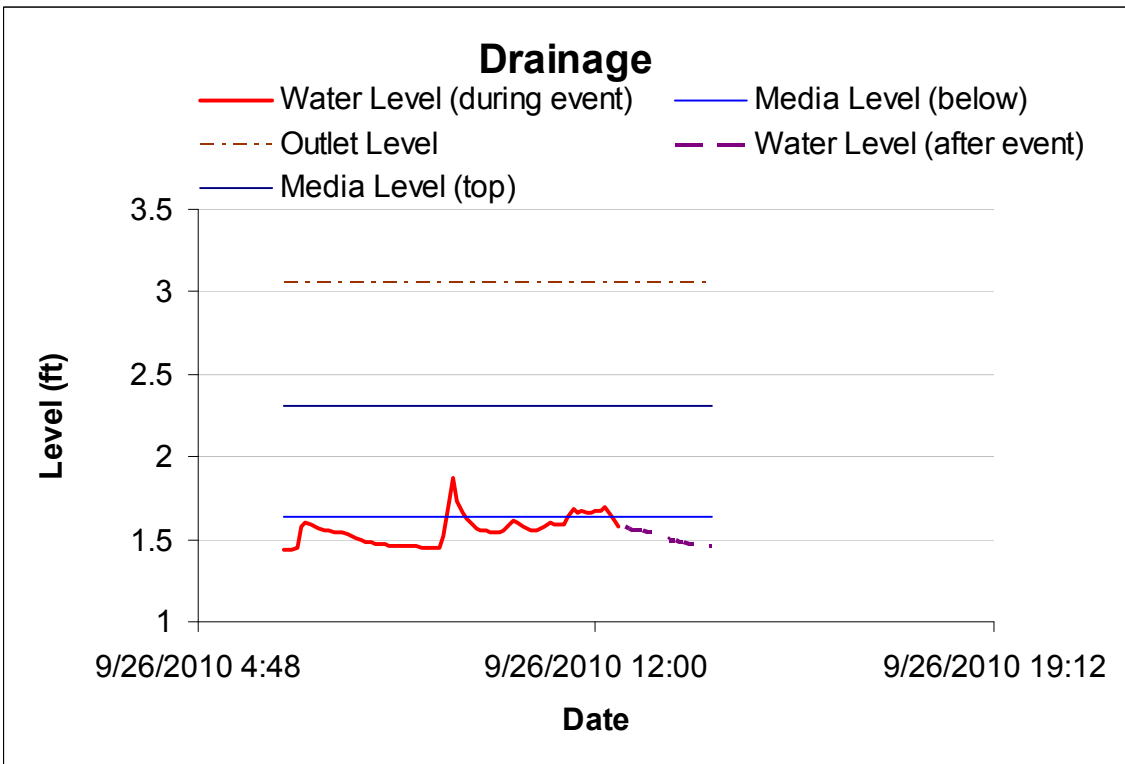
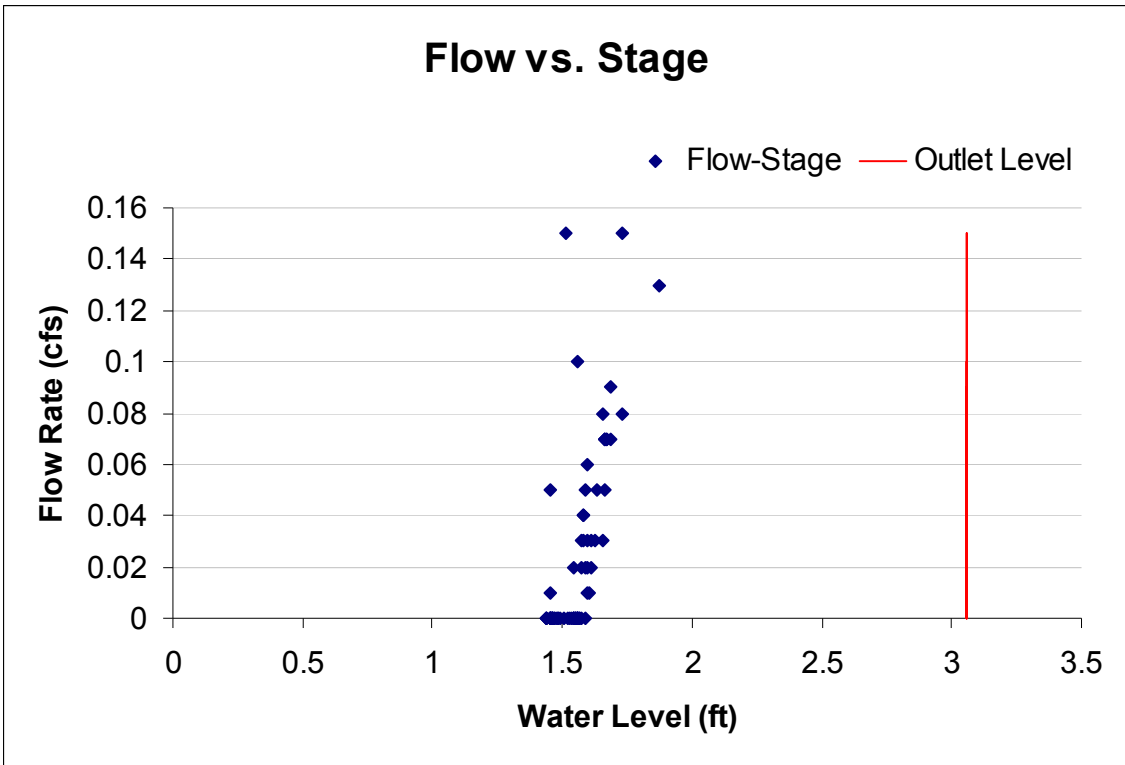

Appendix H.5: October 12, 2010 Rain Event Analysis

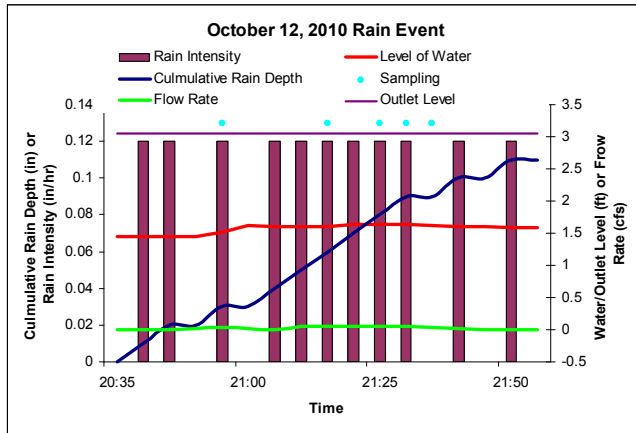

Site Information			
Site Name:	Bama Belle Parking Deck		
Site Location:	N(33°12'50") W(87°34'17")		
Drainage Area (ac):	0.9		
Percent Impervious (%):	67.8		
Runoff Curve Number	84.1		
Rational Number	0.6		
Storm Information – October 12, 2010 Storm			
	Goal	Value	QA note
Precipitation Total (in):	≥0.1	0.11	
Precipitation Duration (hr):	≥1	1.4	
Average Intensity (in/hr):	NA	0.08	
Peak Rain Intensity (in/hr):	NA	0.12	
Storm Volume (gal):	NA	830	(0.034 in)
Maximum Discharge (cfs):	NA	0.06	
Ave Discharge Rate (cfs):	NA	0.02	
Peak to Ave Discharge Ratio:	NA	3.0	
Dry Period (hr):	≥6	≥6	
Estimated Rational Coefficient	NA	0.6	
Volumetric Runoff Coefficient	NA	0.3	

Sampling Information						
	Goal	IN	QA	Out	QA	note
Aliquots:	≥5	5		5		
% Storm:	≥75	100		100		
	Value					
Total Bypass Volume (gal):	0					
% Bypassed to Total (%):	0					

Analysis Information							
EMC Concentration (mg/L, CFU/100mL, #)							
	IN	note	OUT	note	MDL	note	% Conc. Reduction
TSS	59.0		18.0		NA		69.5
SSC	50.0		14.0		NA		72.0
TDS	93.0		70.8		NA		23.9
Conductivity	127.8		111.1		0 to 199,900 μS		13.1
PH	6.62		6.71		-2.00 to 19.99		-1.4
Turbidity	27.8		7.9		0 to 4000 NTU		71.5
Total COD	76		66		0 to 150 mg/L		13.2
Dissolved COD	57		55		0 to 150 mg/L		3.5
Total P	1.34		0.85		0.00 to 3.50 mg/L		36.6
Dissolved P	0.63		0.58		0.00 to 5.00 mg/L		7.9
Ammonia	0.06		0.05		0 to 2.5 mg/L		16.7
Nitrate	0.9		0.8		0 to 5.0 mg/L		11.1
Total N	3		2		0 to 2.5 mg/L		33.3
Dissolved N	2		1		0 to 2.5 mg/L		50.0
Total Zn	BDL		BDL		0.02 mg/L		-
Dissolved Zn	BDL		BDL		0.02 mg/L		-
Total Cd	BDL		BDL		0.005 mg/L		-
Dissolved Cd	BDL		BDL		0.005 mg/L		-
Total Cr	BDL		BDL		0.02 mg/L		-
Dissolved Cr	BDL		BDL		0.02 mg/L		-
Total Cu	BDL		BDL		0.02 mg/L		-
Dissolved Cu	BDL		BDL		0.02 mg/L		-
Total Pb	BDL		BDL		0.005 mg/L		-
Dissolved Pb	BDL		BDL		0.005 mg/L		-
E-Coli	3150		1350		10-24196		57.1
Enterococci	720		500		10-24196		30.6

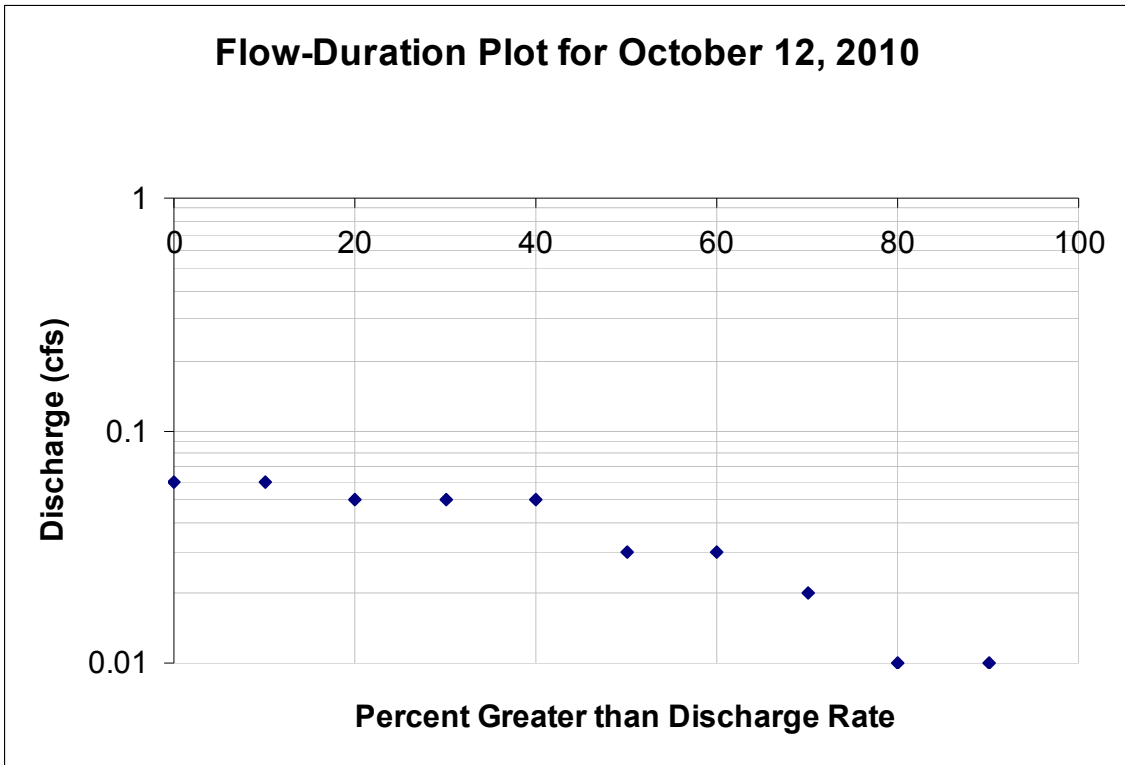
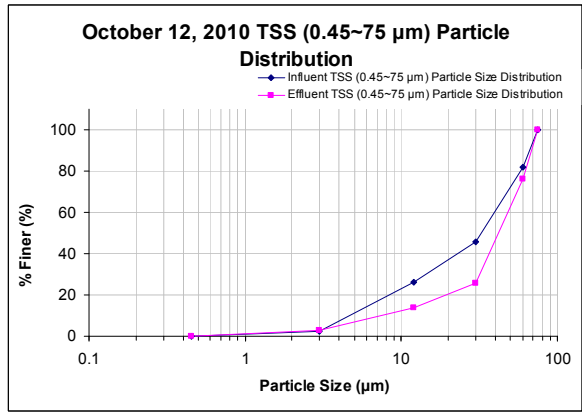
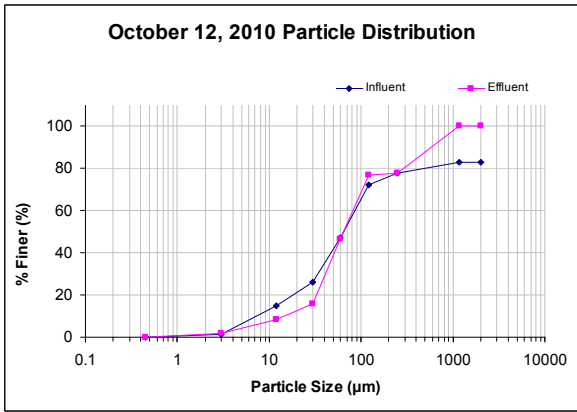

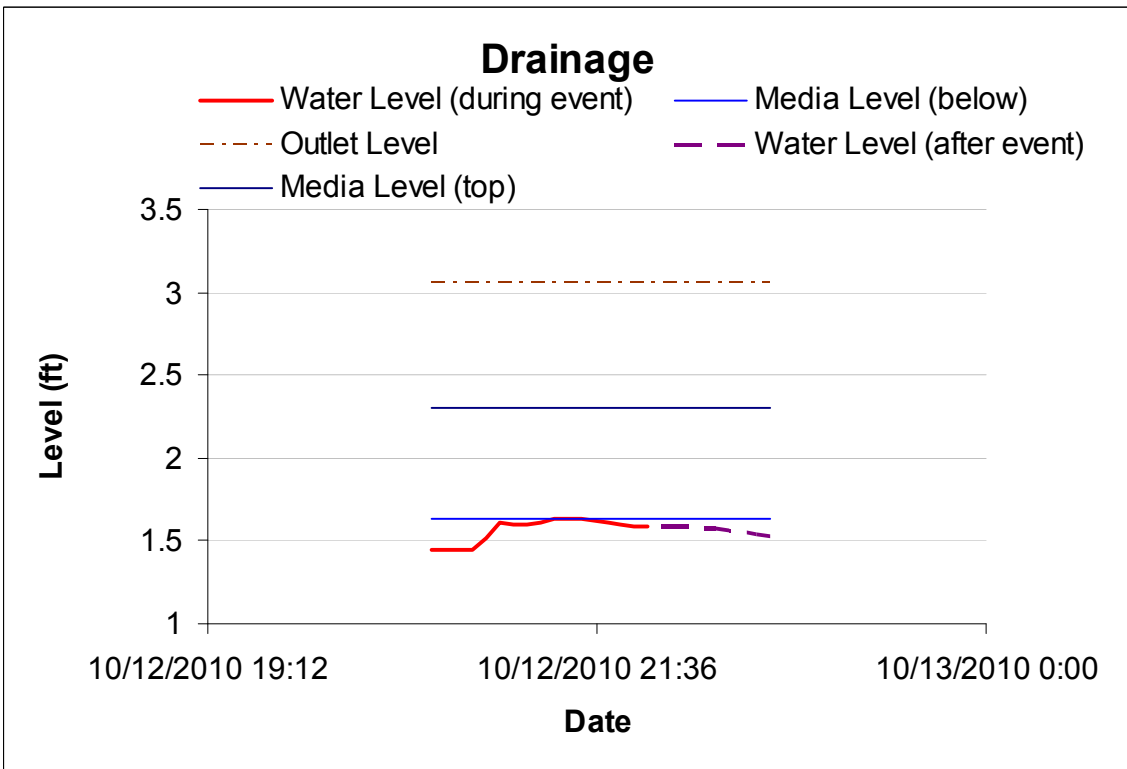
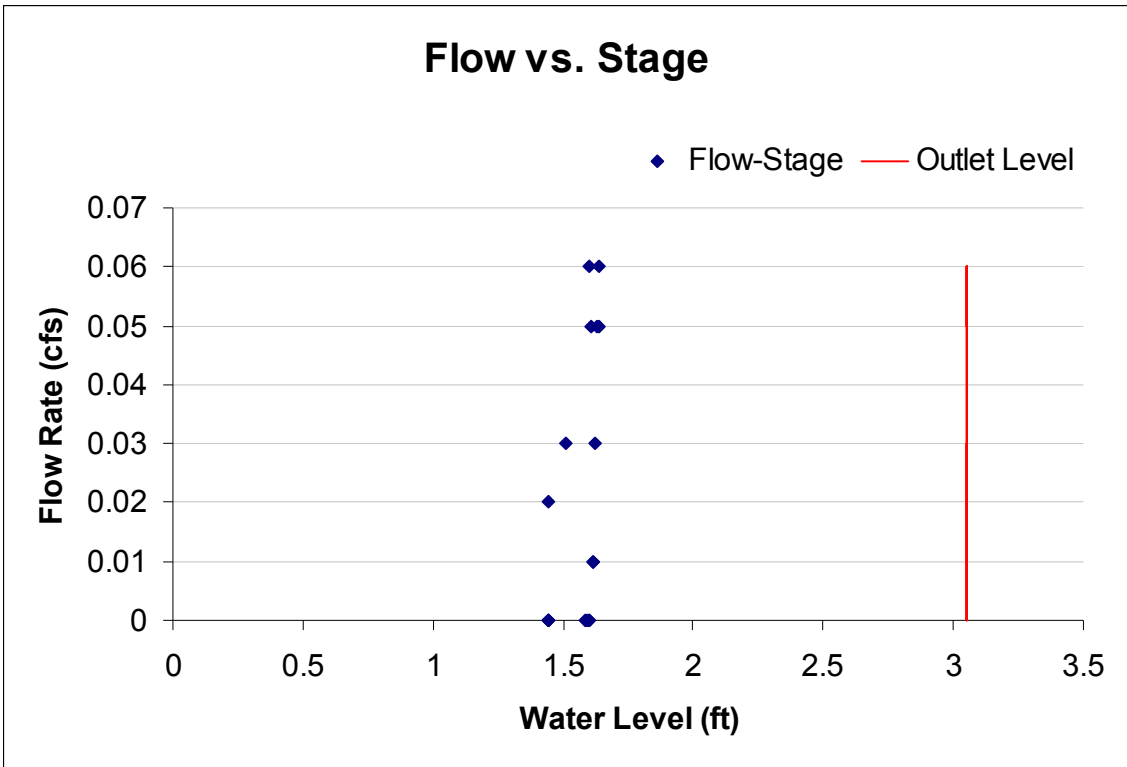

Appendix H.6: October 25, 2010 Rain Event Analysis

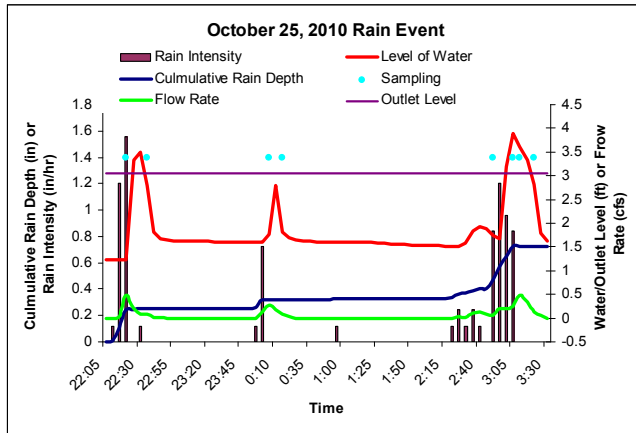

Site Information			
Site Name:	Bama Belle Parking Deck		
Site Location:	N(33°12'50") W(87°34'17")		
Drainage Area (ac):	0.9		
Percent Impervious (%):	67.8		
Runoff Curve Number	84.1		
Rational Number	0.6		
Storm Information – October 25, 2010 Storm			
	Goal	Value	QA note
Precipitation Total (in):	≥0.1	0.72	
Precipitation Duration (hr):	≥1	5.5	
Average Intensity (in/hr):	NA	0.13	
Peak Rain Intensity (in/hr):	NA	1.6	
Storm Volume (gal):	NA	8102	(0.337 in)
Maximum Discharge (cfs):	NA	0.47	
Ave Discharge Rate (cfs):	NA	0.05	
Peak to Ave Discharge Ratio:	NA	9.4	
Dry Period (hr):	≥6	≥6	
Estimated Rational Coefficient	NA	0.3	
Volumetric Runoff Coefficient	NA	0.5	

Sampling Information					
	Goal	IN	QA	Out	QA note
Aliquots:	≥5	8		8	
% Storm:	≥75	100		100	
	Value				
Total Bypass Volume (gal):	238				
% Bypassed to Total (%):	2.9				

Analysis Information						
EMC Concentration (mg/L, CFU/100mL, #)						
	IN	note	OUT	note	MDL	note
						% Conc. Reduction
TSS	94.5		21.7		NA	90.1
SSC	90.0		20.0		NA	77.8
TDS	137.3		77.5		NA	43.6
Conductivity	101.4		94.3		0 to 199,900 μS	7.0
PH	6.60		6.68		-2.00 to 19.99	-1.2
Turbidity	12.4		7.1		0 to 4000 NTU	42.7
Total COD	24		10		0 to 150 mg/L	58.3
Dissolved COD	22		7		0 to 150 mg/L	68.2
Total P	2.24		0.84		0.00 to 3.50 mg/L	62.5
Dissolved P	1.1		0.55		0.00 to 5.00 mg/L	50.0
Ammonia	0.05		0.04		0 to 2.5 mg/L	20.0
Nitrate	0.8		0.6		0 to 5.0 mg/L	25.0
Total N	3		2		0 to 2.5 mg/L	33.3
Dissolved N	2		1		0 to 2.5 mg/L	50.0
Total Zn	BDL		BDL		0.02 mg/L	-
Dissolved Zn	BDL		BDL		0.02 mg/L	-
Total Cd	BDL		BDL		0.005 mg/L	-
Dissolved Cd	BDL		BDL		0.005 mg/L	-
Total Cr	BDL		BDL		0.02 mg/L	-
Dissolved Cr	BDL		BDL		0.02 mg/L	-
Total Cu	BDL		BDL		0.02 mg/L	-
Dissolved Cu	BDL		BDL		0.02 mg/L	-
Total Pb	BDL		BDL		0.005 mg/L	-
Dissolved Pb	BDL		BDL		0.005 mg/L	-
E-Coli	6240		1460		10-24196	76.6
Enterococci	3830		810		10-24196	78.9

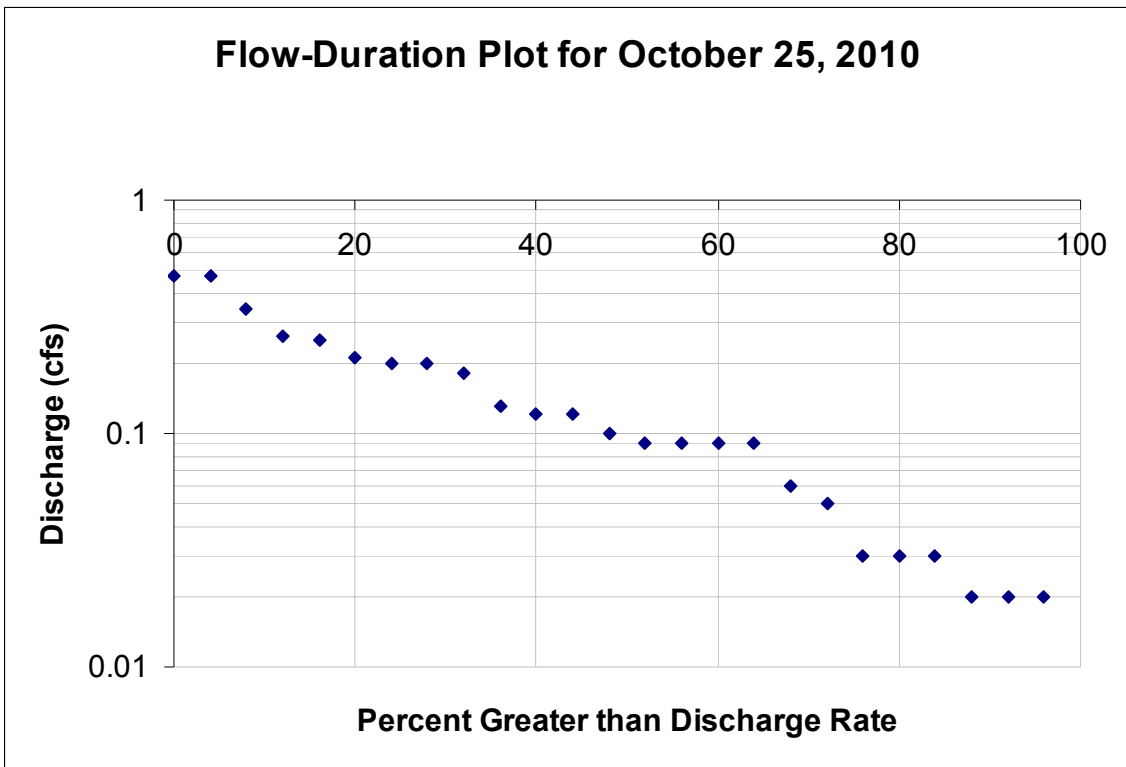
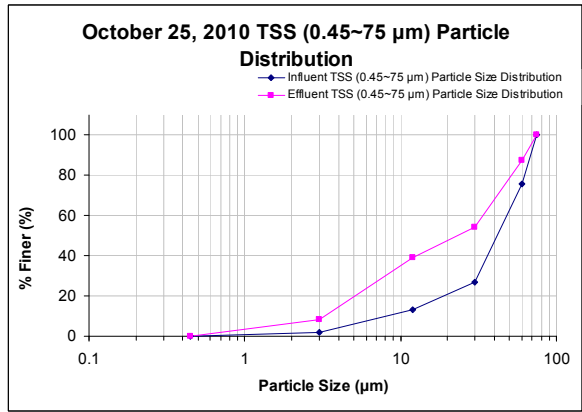
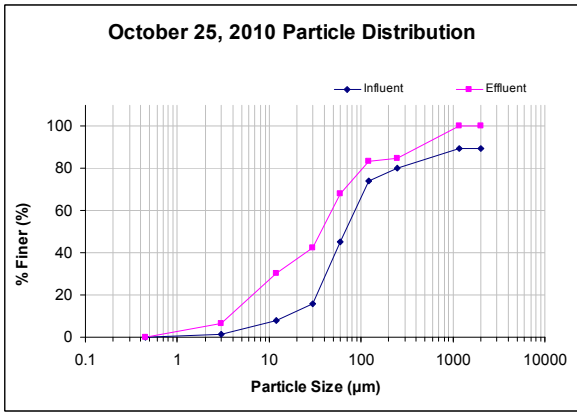

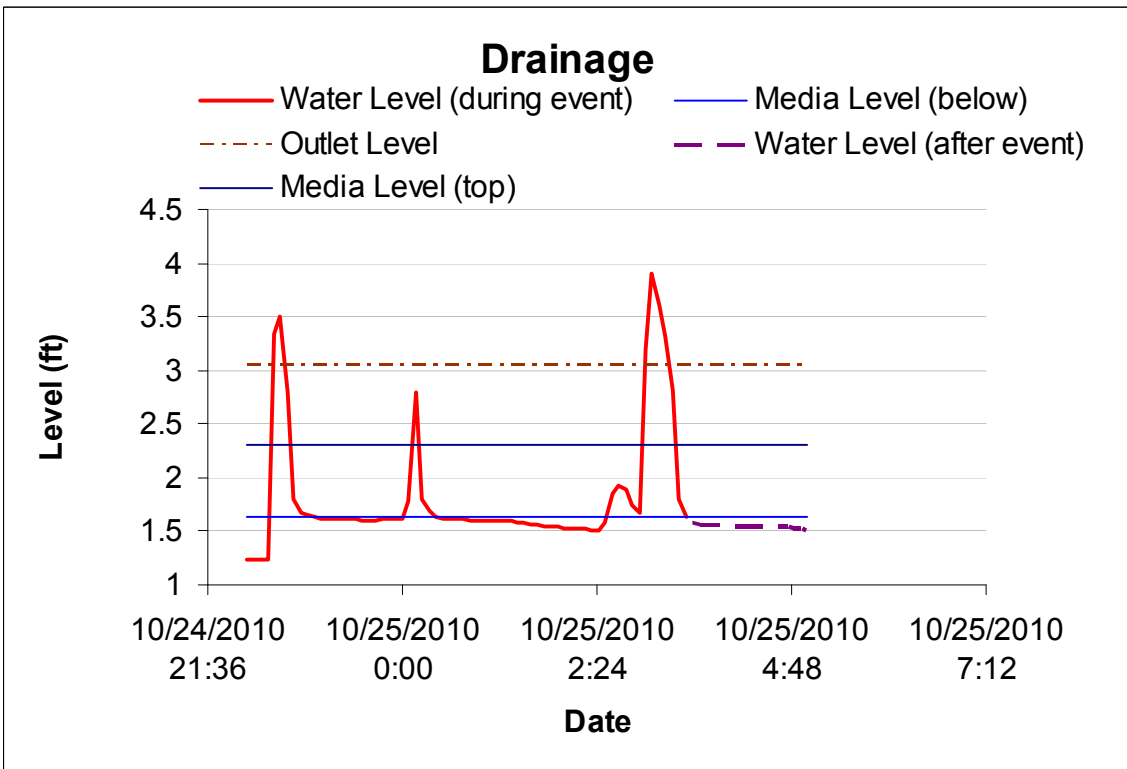
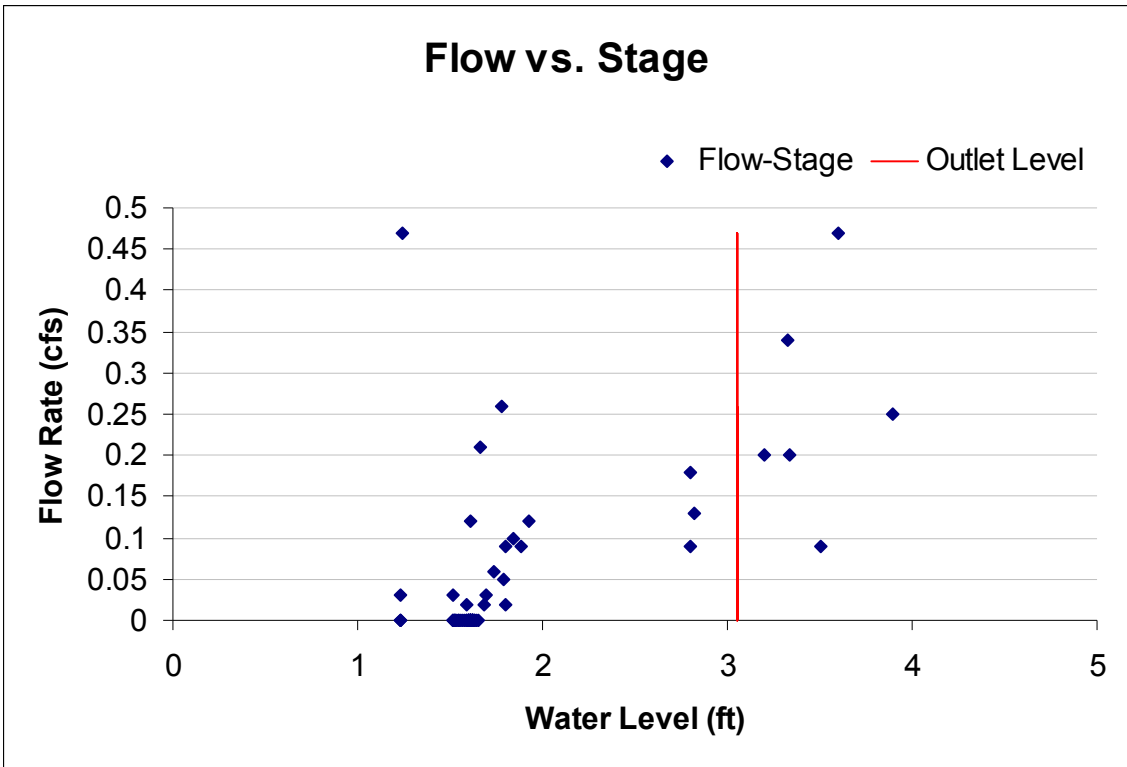

Appendix H.7: October 28, 2010 Rain Event Analysis

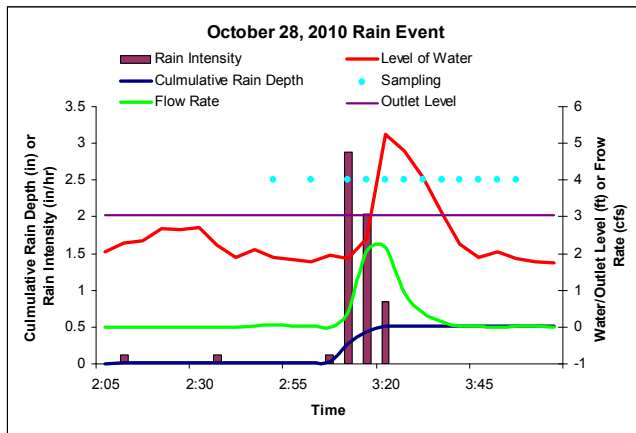

Site Information			
Site Name:	Bama Belle Parking Deck		
Site Location:	N(33°12'50") W(87°34'17")		
Drainage Area (ac):	0.9		
Percent Impervious (%):	67.8		
Runoff Curve Number	84.1		
Rational Number	0.6		
Storm Information – October 28, 2010 Storm			
	Goal	Value	QA note
Precipitation Total (in):	≥0.1	0.51	
Precipitation Duration (hr):	≥1	2.1	
Average Intensity (in/hr):	NA	0.24	
Peak Rain Intensity (in/hr):	NA	2.9	
Storm Volume (gal):	NA	14273	(0.593 in)
Maximum Discharge (cfs):	NA	2.2	
Ave Discharge Rate (cfs):	NA	0.25	
Peak to Ave Discharge Ratio:	NA	8.6	
Dry Period (hr):	≥6	≥6	
Estimated Rational Coefficient	NA	0.8	
Volumetric Runoff Coefficient	NA	1.2	

Sampling Information						
	Goal	IN	QA	Out	QA	note
Aliquots:	≥5	12		12		
% Storm:	≥75	100		100		
	Value					
Total Bypass Volume (gal):	468					
% Bypassed to Total (%):	3.3					

Analysis Information							
EMC Concentration (mg/L, CFU/100mL, #)							
	IN	note	OUT	note	MDL	note	% Conc. Reduction
TSS	103.6		21.7		NA		79.1
SSC	107.0		24.0		NA		77.6
TDS	130.9		60.8		NA		53.6
Conductivity	127.2		95.6		0 to 199,900 μS		24.8
PH	6.61		6.87		-2.00 to 19.99		-3.9
Turbidity	28.7		7.0		0 to 4000 NTU		75.6
Total COD	92		73		0 to 150 mg/L		20.7
Dissolved COD	79		55		0 to 150 mg/L		30.4
Total P	1.8		0.84		0.00 to 3.50 mg/L		53.3
Dissolved P	0.61		0.54		0.00 to 5.00 mg/L		11.5
Ammonia	0.04		0.01		0 to 2.5 mg/L		75.0
Nitrate	1.0		0.8		0 to 5.0 mg/L		20.0
Total N	3		2		0 to 2.5 mg/L		33.3
Dissolved N	2		1		0 to 2.5 mg/L		50.0
Total Zn	0.03		BDL		0.02 mg/L		>33.3
Dissolved Zn	BDL		BDL		0.02 mg/L		-
Total Cd	BDL		BDL		0.005 mg/L		-
Dissolved Cd	BDL		BDL		0.005 mg/L		-
Total Cr	BDL		BDL		0.02 mg/L		-
Dissolved Cr	BDL		BDL		0.02 mg/L		-
Total Cu	0.05		0.02		0.02 mg/L		60.0
Dissolved Cu	0.05		BDL		0.02 mg/L		>60.0
Total Pb	BDL		BDL		0.005 mg/L		-
Dissolved Pb	BDL		BDL		0.005 mg/L		-
E-Coli	1870		610		10-24196		67.4
Enterococci	1040		400		10-24196		61.5

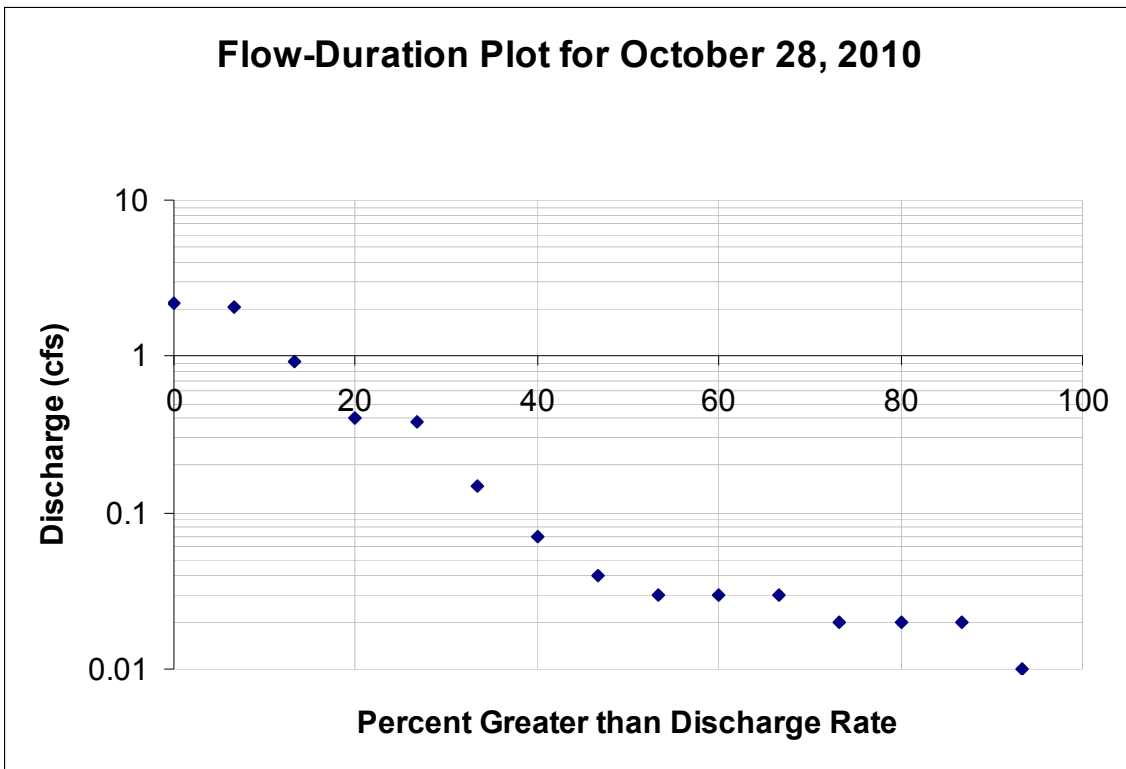
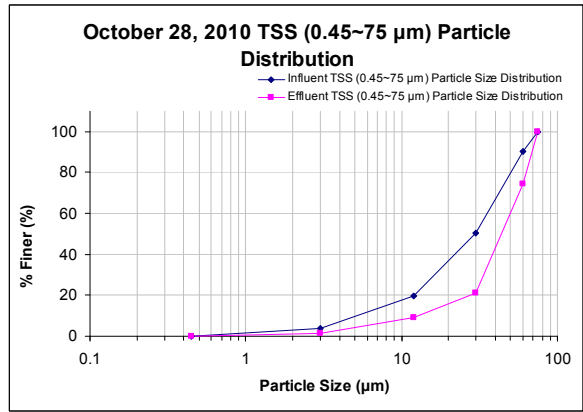
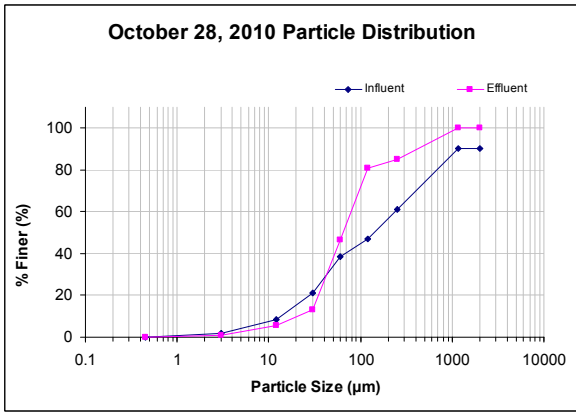

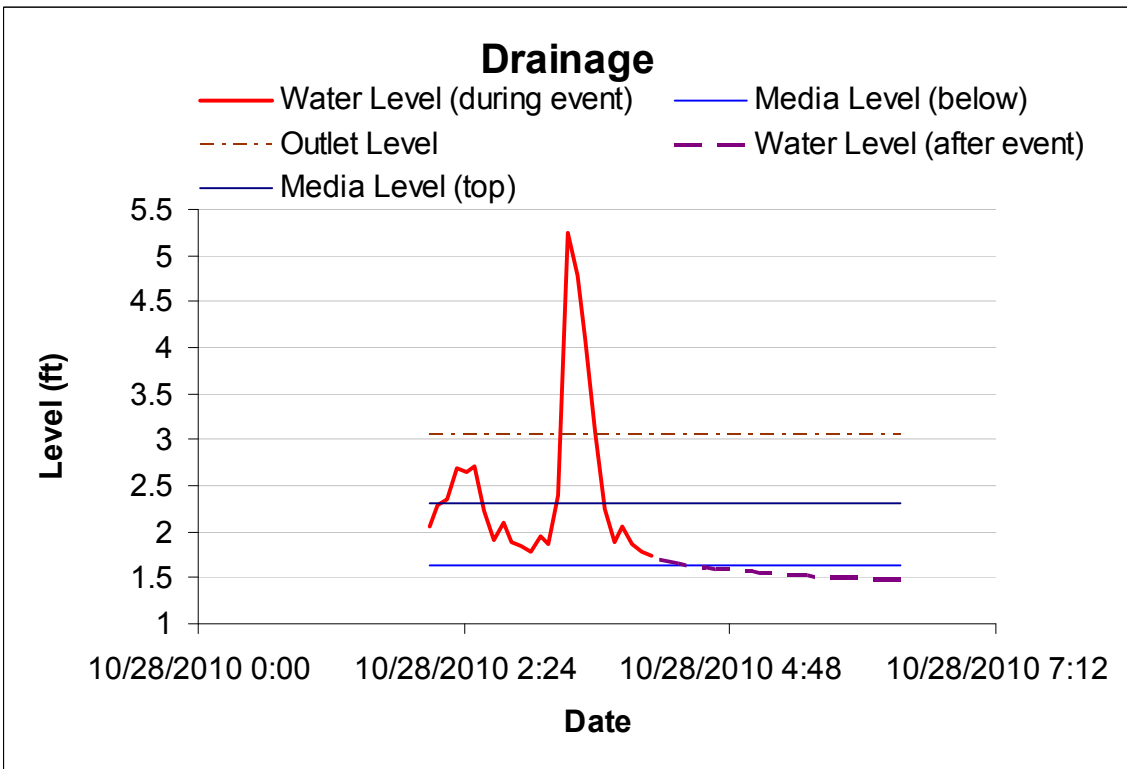
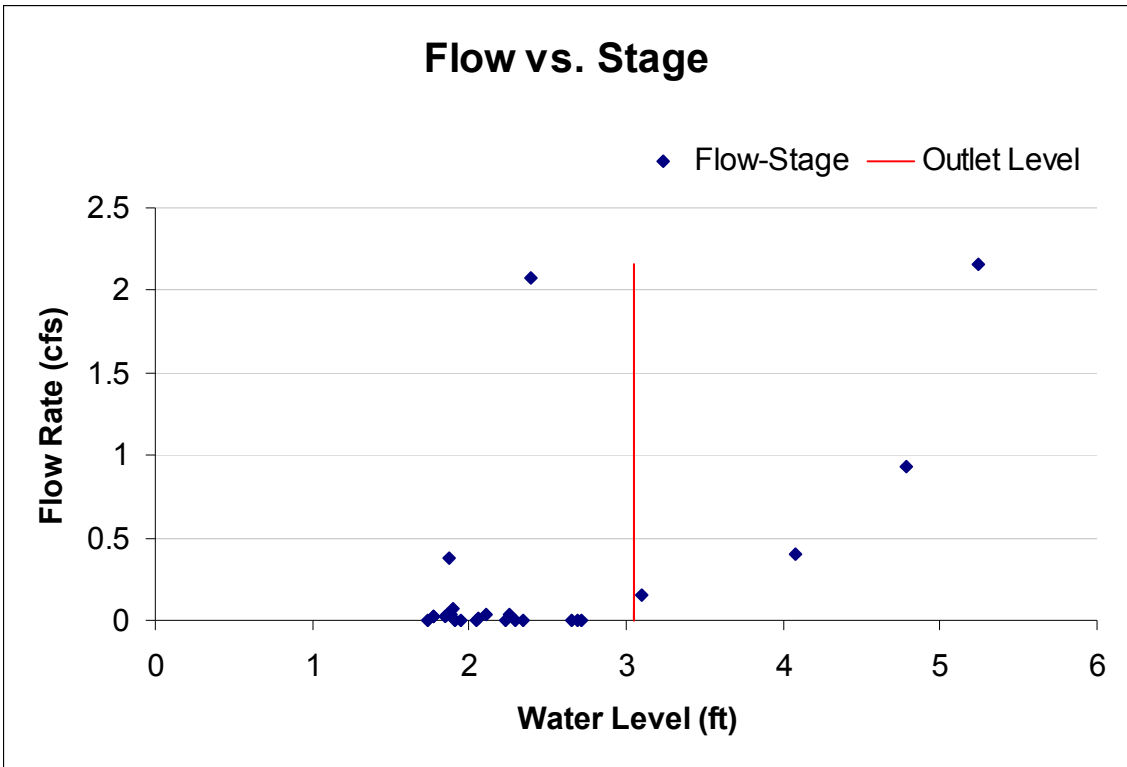

Appendix H.8: November 2, 2010 Rain Event Analysis

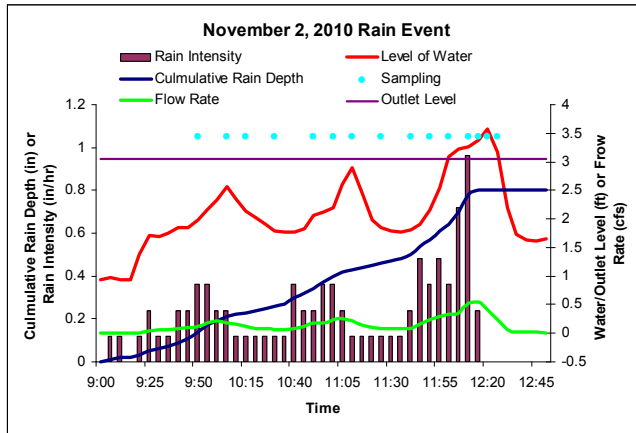

Site Information			
Site Name:	Bama Belle Parking Deck		
Site Location:	N(33°12'50") W(87°34'17")		
Drainage Area (ac):	0.9		
Percent Impervious (%):	67.8		
Runoff Curve Number	84.1		
Rational Number	0.6		
Storm Information – November 2, 2010 Storm			
	Goal	Value	QA note
Precipitation Total (in):	≥0.1	0.8	
Precipitation Duration (hr):	≥1	3.9	
Average Intensity (in/hr):	NA	0.20	
Peak Rain Intensity (in/hr):	NA	0.96	
Storm Volume (gal):	NA	15103	(0.628 in)
Maximum Discharge (cfs):	NA	0.55	
Ave Discharge Rate (cfs):	NA	0.14	
Peak to Ave Discharge Ratio:	NA	3.9	
Dry Period (hr):	≥6	≥6	
Estimated Rational Coefficient	NA	0.6	
Volumetric Runoff Coefficient	NA	0.8	

Sampling Information						
	Goal	IN	QA	Out	QA	note
Aliquots:	≥5	15		15		
% Storm:	≥75	100		100		
	Value					
Total Bypass Volume (gal):	128					
% Bypassed to Total (%):	0.84					

Analysis Information							
EMC Concentration (mg/L, CFU/100mL, #)							
	IN	note	OUT	note	MDL	note	% Conc. Reduction
TSS	72.0		37.0		NA		48.6
SSC	77.0		33.0		NA		57.1
TDS	77.0		35.0		NA		54.5
Conductivity	87.4		69.1		0 to 199,900 μS		20.9
PH	6.60		6.69		-2.00 to 19.99		-1.4
Turbidity	15.4		7.1		0 to 4000 NTU		54.0
Total COD	17		14		0 to 150 mg/L		17.6
Dissolved COD	15		12		0 to 150 mg/L		20.0
Total P	1.23		1.19		0.00 to 3.50 mg/L		3.3
Dissolved P	0.76		0.71		0.00 to 5.00 mg/L		6.6
Ammonia	0.34		0.01		0 to 2.5 mg/L		97.1
Nitrate	0.7		0.5		0 to 5.0 mg/L		28.6
Total N	2		1		0 to 2.5 mg/L		50.0
Dissolved N	1		0		0 to 2.5 mg/L		100
Total Zn	BDL		BDL		0.02 mg/L		-
Dissolved Zn	BDL		BDL		0.02 mg/L		-
Total Cd	BDL		BDL		0.005 mg/L		-
Dissolved Cd	BDL		BDL		0.005 mg/L		-
Total Cr	BDL		BDL		0.02 mg/L		-
Dissolved Cr	BDL		BDL		0.02 mg/L		-
Total Cu	BDL		BDL		0.02 mg/L		-
Dissolved Cu	BDL		BDL		0.02 mg/L		-
Total Pb	BDL		BDL		0.005 mg/L		-
Dissolved Pb	BDL		BDL		0.005 mg/L		-
E-Coli	3240		1210		10-24196		62.7
Enterococci	12660		9040		10-24196		28.6

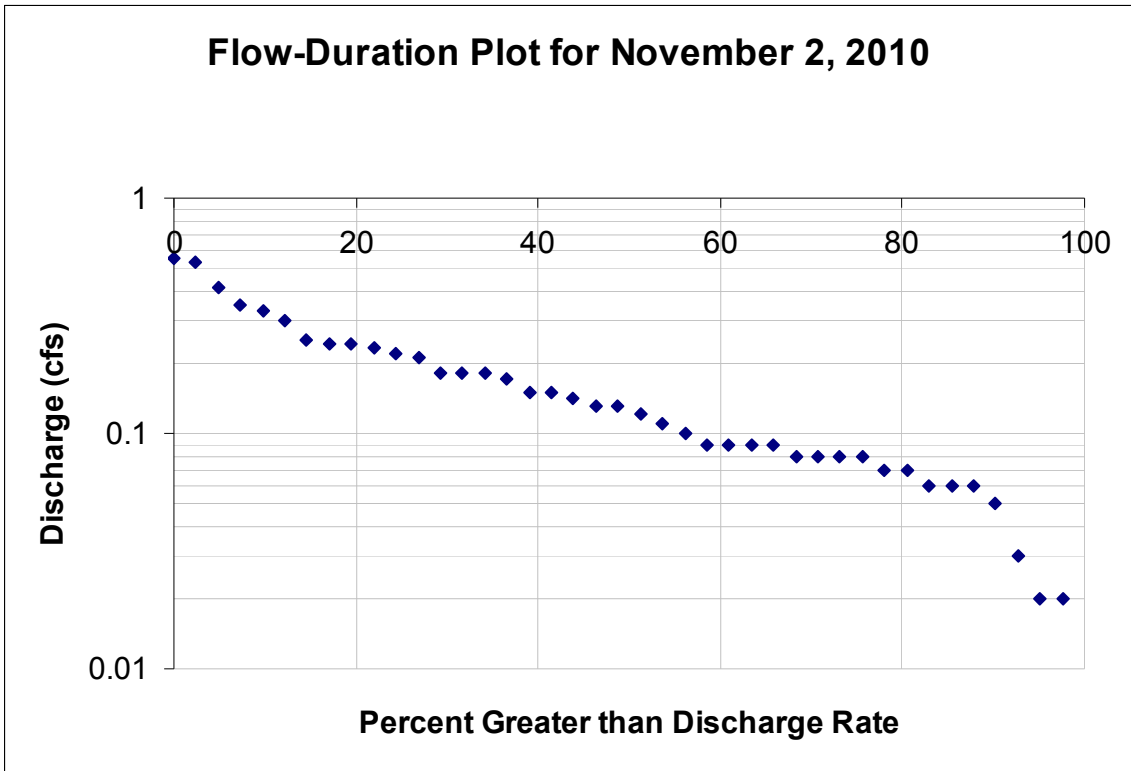
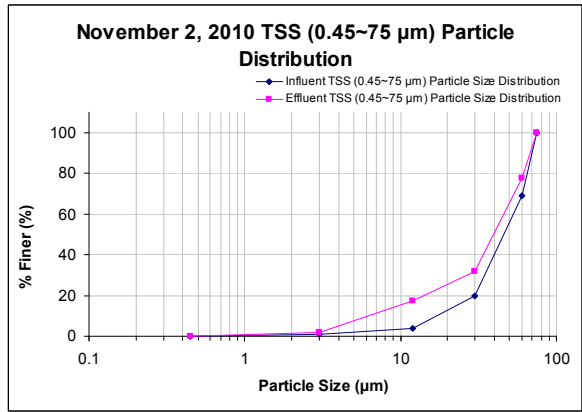
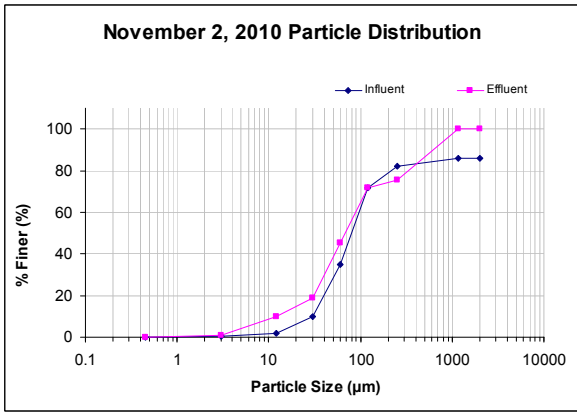

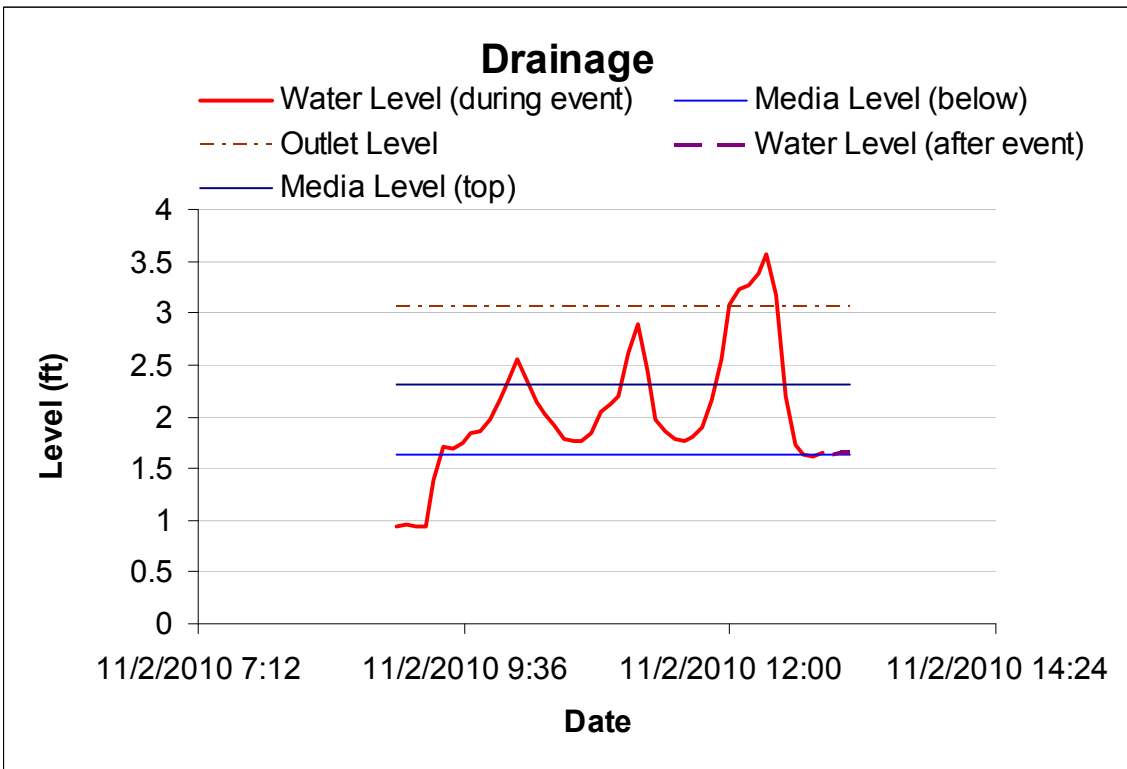
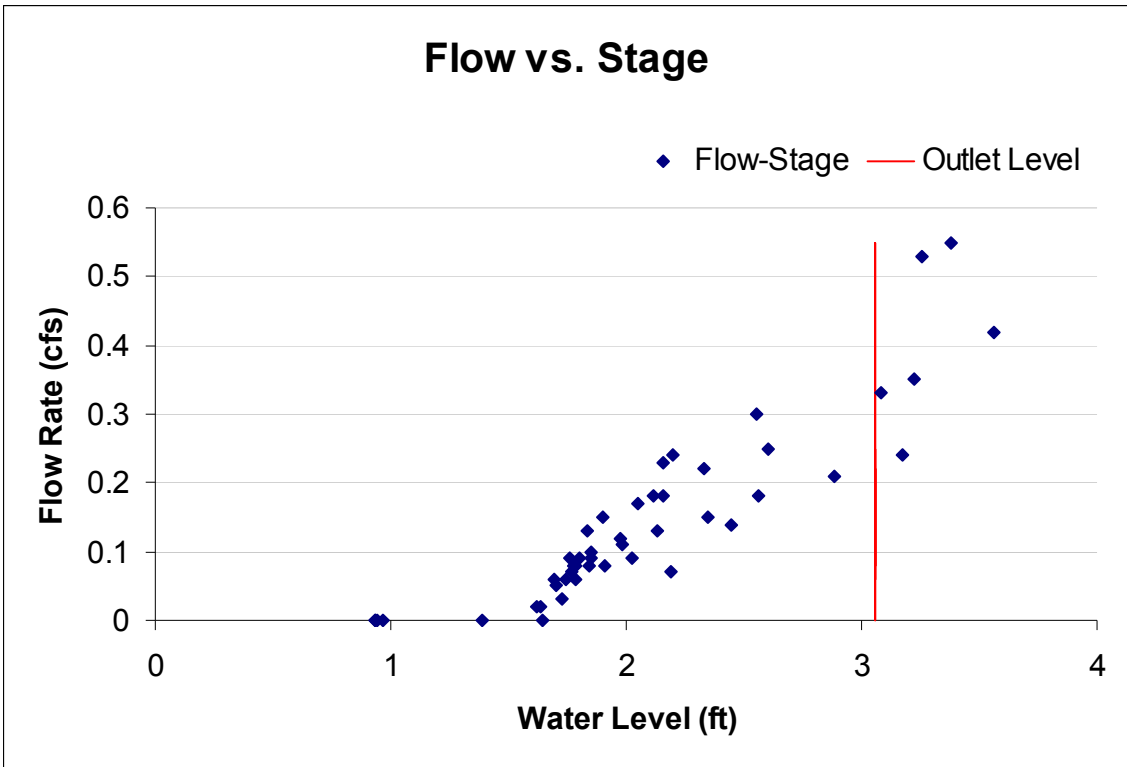

Appendix H.9: November 3, 2010 Rain Event Analysis

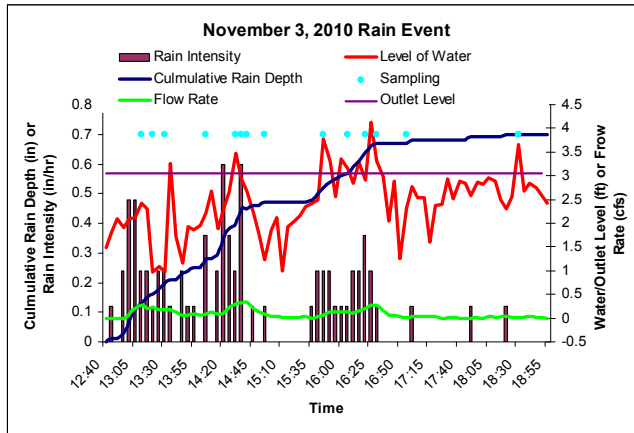

Site Information			
Site Name:	Bama Belle Parking Deck		
Site Location:	N(33°12'50") W(87°34'17")		
Drainage Area (ac):	0.9		
Percent Impervious (%):	67.8		
Runoff Curve Number	84.1		
Rational Number	0.6		
Storm Information – November 3, 2010 Storm			
	Goal	Value	QA note
Precipitation Total (in):	≥0.1	0.7	
Precipitation Duration (hr):	≥1	6.3	
Average Intensity (in/hr):	NA	0.11	
Peak Rain Intensity (in/hr):	NA	0.60	
Storm Volume (gal):	NA	14452	(0.600 in)
Maximum Discharge (cfs):	NA	0.35	
Ave Discharge Rate (cfs):	NA	0.08	
Peak to Ave Discharge Ratio:	NA	4.4	
Dry Period (hr):	≥6	≥6	
Estimated Rational Coefficient	NA	0.7	
Volumetric Runoff Coefficient	NA	0.9	

Sampling Information					
	Goal	IN	QA	Out	QA note
Aliquots:	≥5	14		14	
% Storm:	≥75	100		100	
	Value				
Total Bypass Volume (gal):	1553				
% Bypassed to Total (%):	10.7				

Analysis Information							
EMC Concentration (mg/L, CFU/100mL, #)							
	IN	note	OUT	note	MDL	note	% Conc. Reduction
TSS	87.0		19.0		NA		78.2
SSC	88.0		19.0		NA		78.4
TDS	126.0		61.7		NA		51.0
Conductivity	56.3		47.8		0 to 199,900 μS		15.1
PH	6.63		6.73		-2.00 to 19.99		-1.5
Turbidity	7.6		4.9		0 to 4000 NTU		36.0
Total COD	12		4		0 to 150 mg/L		66.7
Dissolved COD	4		1		0 to 150 mg/L		75.0
Total P	0.81		0.52		0.00 to 3.50 mg/L		35.8
Dissolved P	0.45		0.40		0.00 to 5.00 mg/L		13.0
Ammonia	0.03		0.01		0 to 2.5 mg/L		66.7
Nitrate	0.5		0.4		0 to 5.0 mg/L		20.0
Total N	3		2		0 to 2.5 mg/L		33.3
Dissolved N	2		1		0 to 2.5 mg/L		50.0
Total Zn	BDL		BDL		0.02 mg/L		-
Dissolved Zn	BDL		BDL		0.02 mg/L		-
Total Cd	BDL		BDL		0.005 mg/L		-
Dissolved Cd	BDL		BDL		0.005 mg/L		-
Total Cr	BDL		BDL		0.02 mg/L		-
Dissolved Cr	BDL		BDL		0.02 mg/L		-
Total Cu	BDL		BDL		0.02 mg/L		-
Dissolved Cu	BDL		BDL		0.02 mg/L		-
Total Pb	BDL		BDL		0.005 mg/L		-
Dissolved Pb	BDL		BDL		0.005 mg/L		-
E-Coli	46110		22820		10-24196		50.5
Enterococci	3860		820		10-24196		78.8

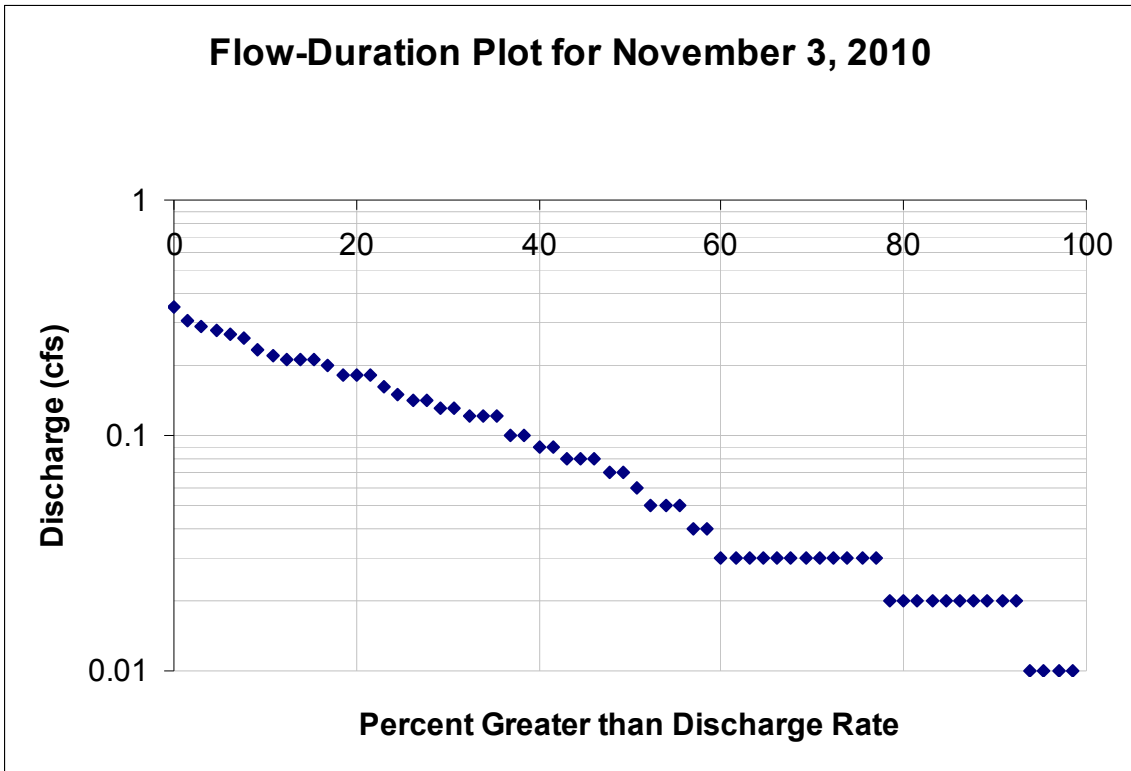
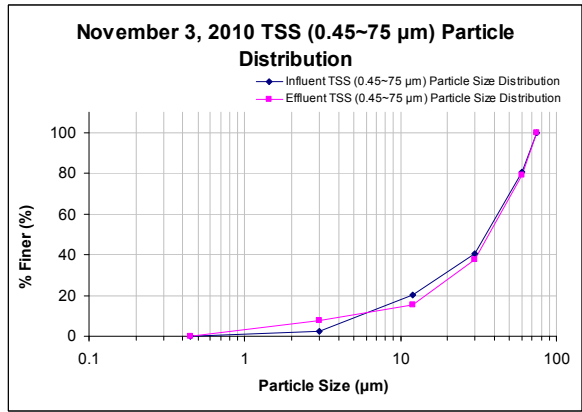
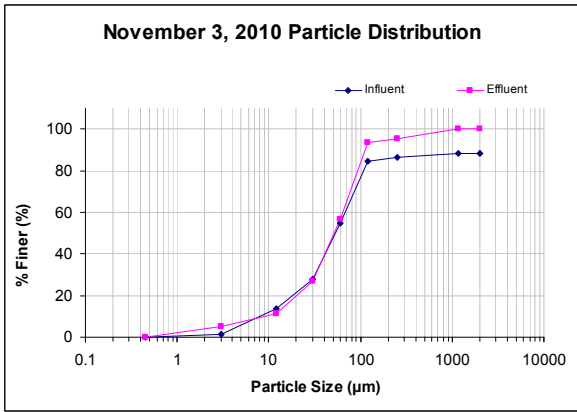

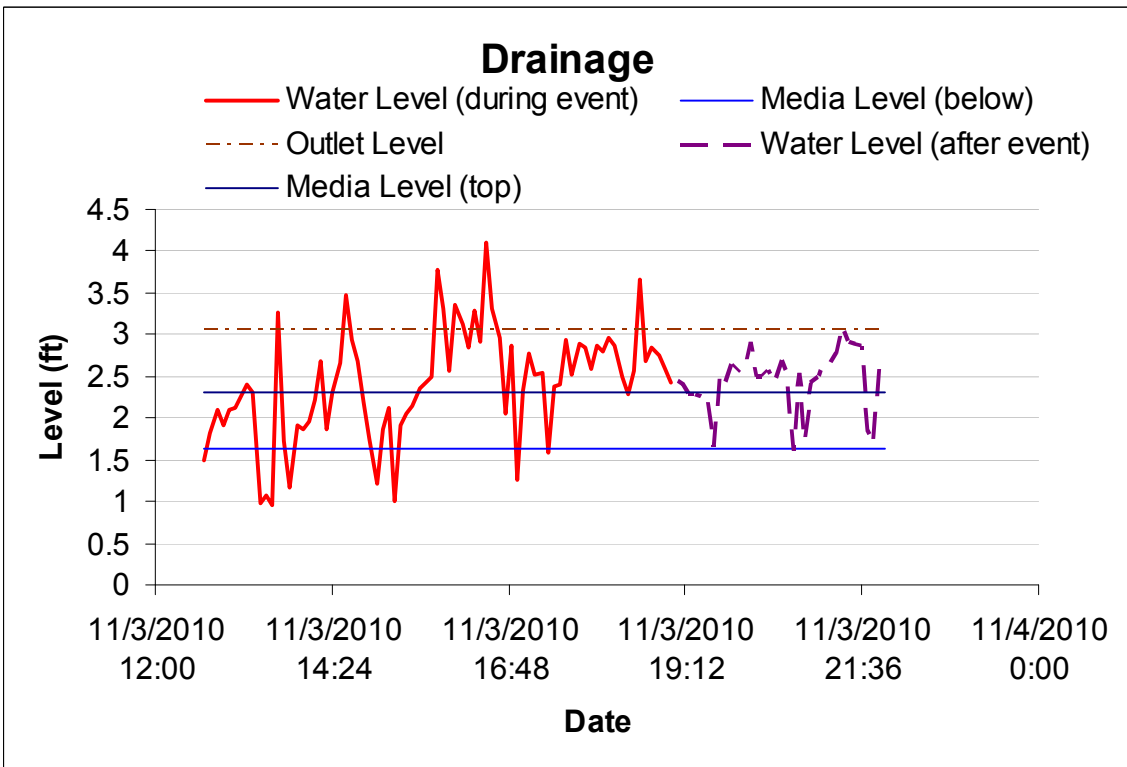
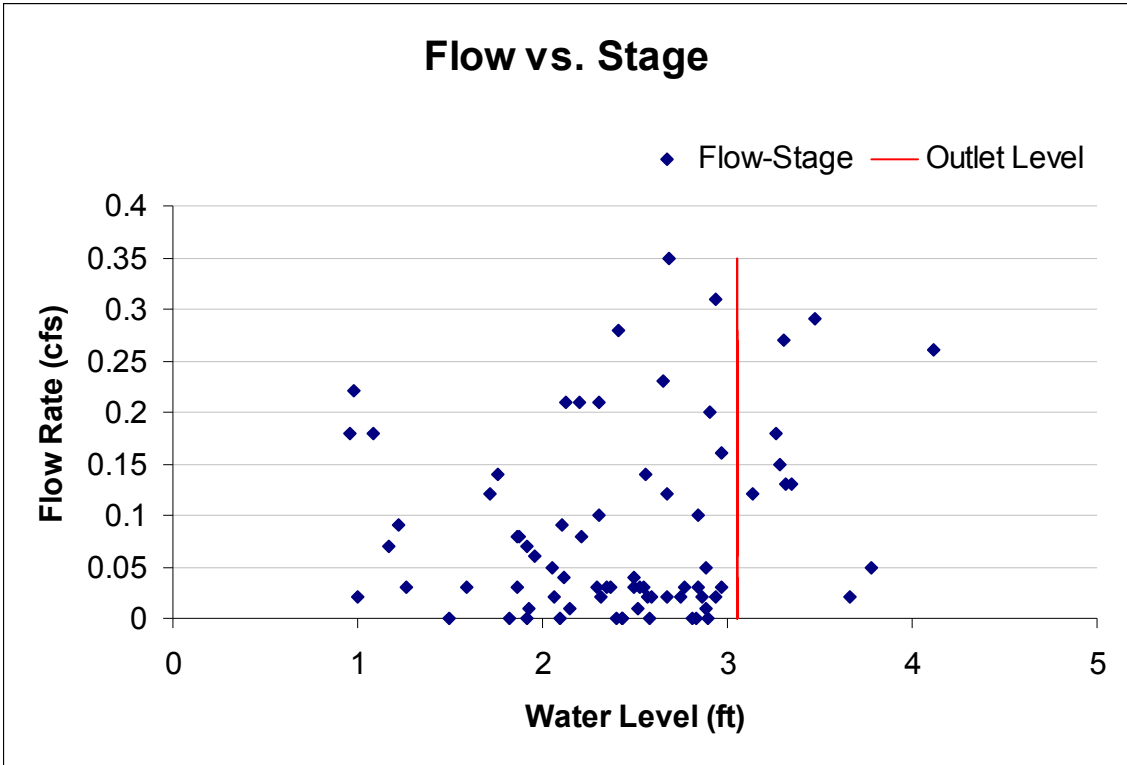

Appendix H.10: December 11, 2010 Rain Event Analysis

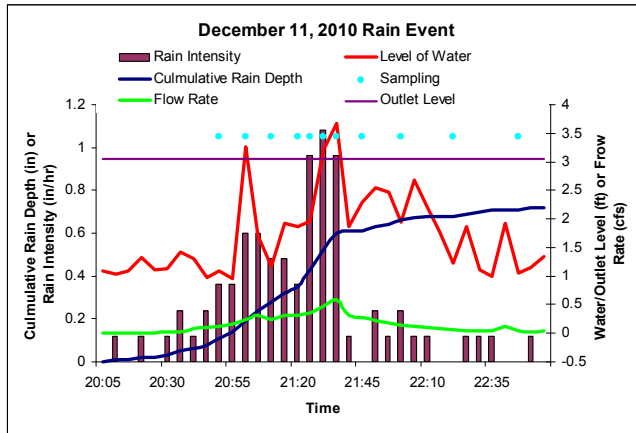

Site Information			
Site Name:	Bama Belle Parking Deck		
Site Location:	N(33°12'50") W(87°34'17")		
Drainage Area (ac):	0.9		
Percent Impervious (%):	67.8		
Runoff Curve Number	84.1		
Rational Number	0.6		
Storm Information – December 11, 2010 Storm			
	Goal	Value	QA note
Precipitation Total (in):	≥0.1	0.72	
Precipitation Duration (hr):	≥1	2.9	
Average Intensity (in/hr):	NA	0.25	
Peak Rain Intensity (in/hr):	NA	1.08	
Storm Volume (gal):	NA	11670	(0.485 in)
Maximum Discharge (cfs):	NA	0.58	
Ave Discharge Rate (cfs):	NA	0.15	
Peak to Ave Discharge Ratio:	NA	3.9	
Dry Period (hr):	≥6	≥6	
Estimated Rational Coefficient	NA	0.6	
Volumetric Runoff Coefficient	NA	0.7	

Sampling Information						
	Goal	IN	QA	Out	QA	note
Aliquots:	≥5	11		11		
% Storm:	≥75	100		100		
	Value					
Total Bypass Volume (gal):	93					
% Bypassed to Total (%):	0.8					

Analysis Information							
EMC Concentration (mg/L, CFU/100mL, #)							
	IN	note	OUT	note	MDL	note	% Conc. Reduction
TSS	95.0		39.0		NA		58.9
SSC	131.0		50.3		NA		61.6
TDS	126.0		115.8		NA		8.1
Conductivity	77.0		66.7		0 to 199,900 μS		13.4
PH	6.61		6.71		-2.00 to 19.99		-1.5
Turbidity	35.5		20.1		0 to 4000 NTU		43.4
Total COD	14		10		0 to 150 mg/L		28.6
Dissolved COD	5		1		0 to 150 mg/L		80.0
Total P	1.61		1.29		0.00 to 3.50 mg/L		19.9
Dissolved P	0.84		0.71		0.00 to 5.00 mg/L		15.5
Ammonia	0.12		0.03		0 to 2.5 mg/L		75.0
Nitrate	2.2		0.8		0 to 5.0 mg/L		63.6
Total N	2		1		0 to 2.5 mg/L		50.0
Dissolved N	1		0		0 to 2.5 mg/L		100.0
Total Zn	BDL		BDL		0.02 mg/L		-
Dissolved Zn	BDL		BDL		0.02 mg/L		-
Total Cd	BDL		BDL		0.005 mg/L		-
Dissolved Cd	BDL		BDL		0.005 mg/L		-
Total Cr	BDL		BDL		0.02 mg/L		-
Dissolved Cr	BDL		BDL		0.02 mg/L		-
Total Cu	BDL		BDL		0.02 mg/L		-
Dissolved Cu	BDL		BDL		0.02 mg/L		-
Total Pb	BDL		BDL		0.005 mg/L		-
Dissolved Pb	BDL		BDL		0.005 mg/L		-
E-Coli	610		200		10-24196		67.2
Enterococci	3500		2330		10-24196		33.4

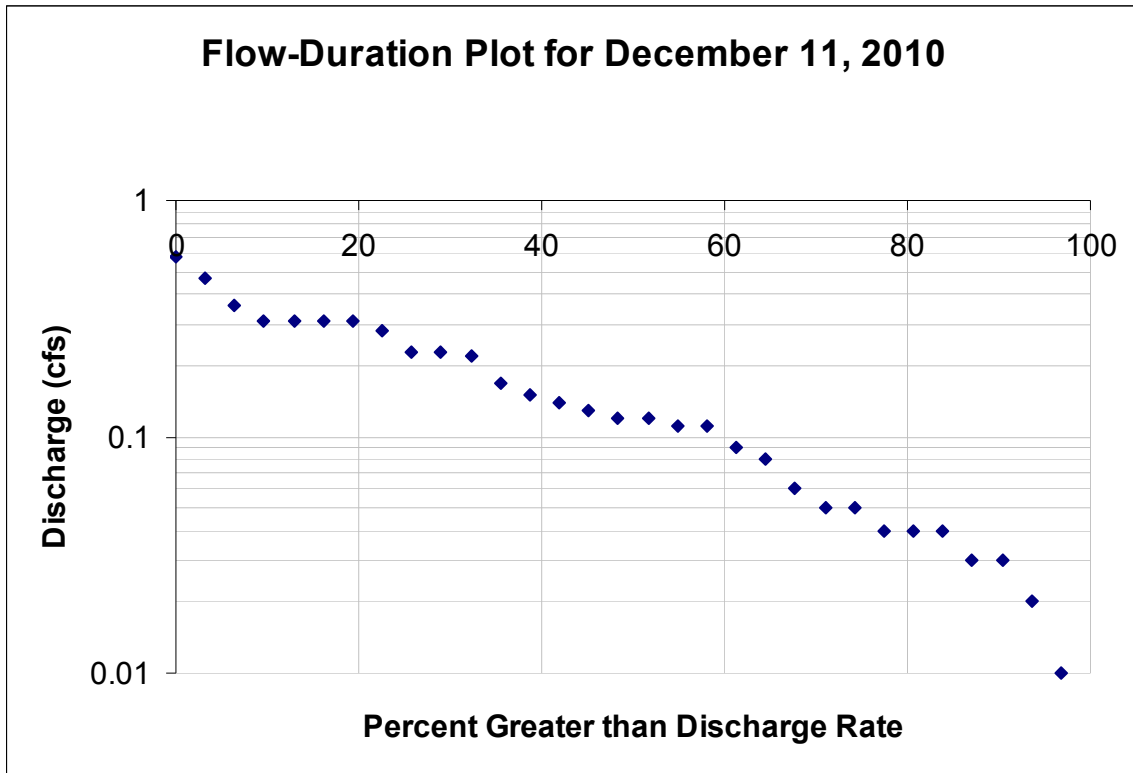
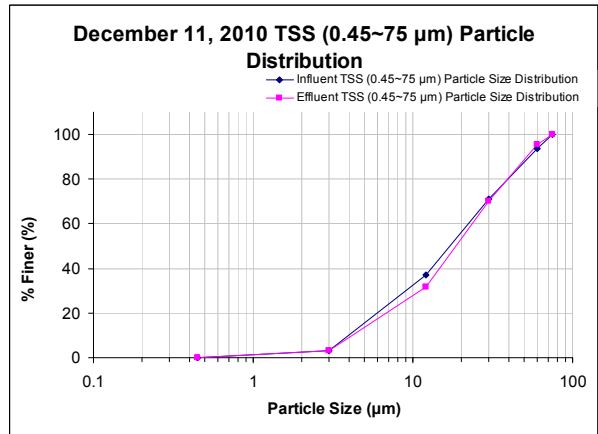
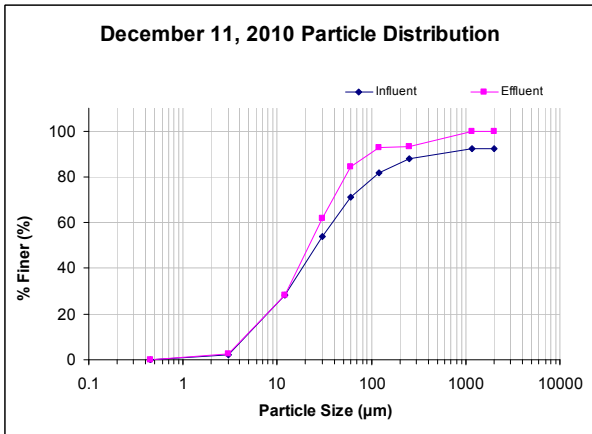

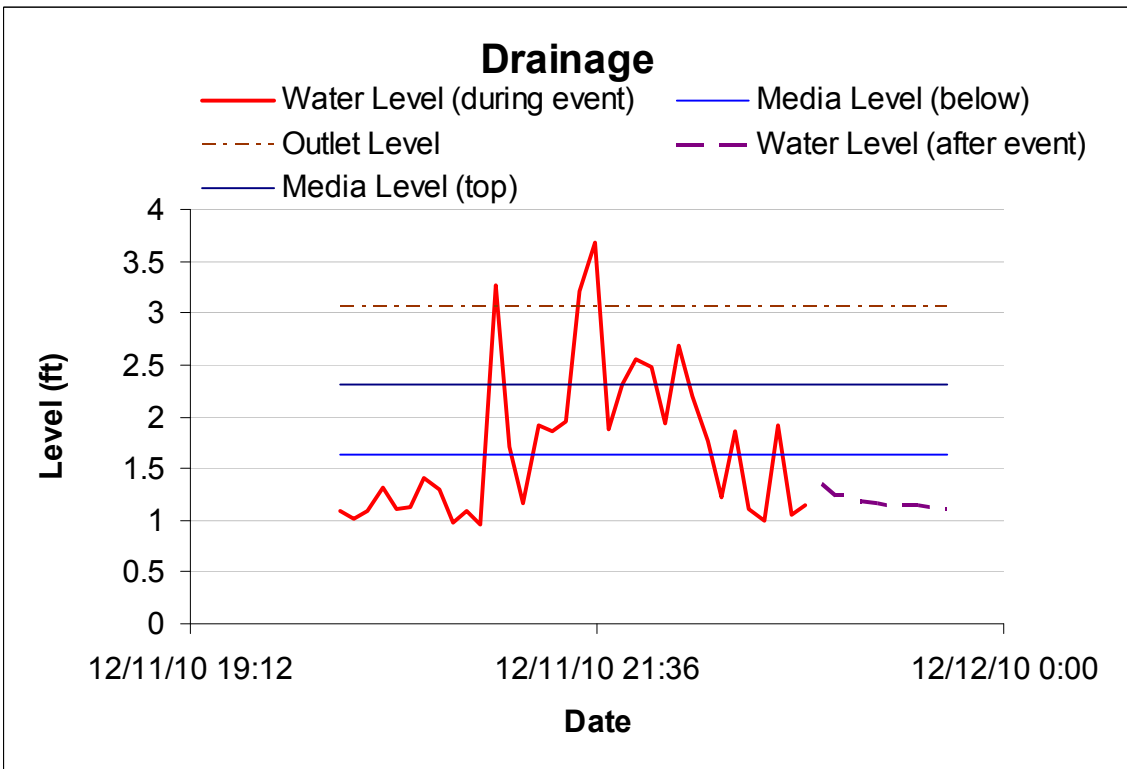
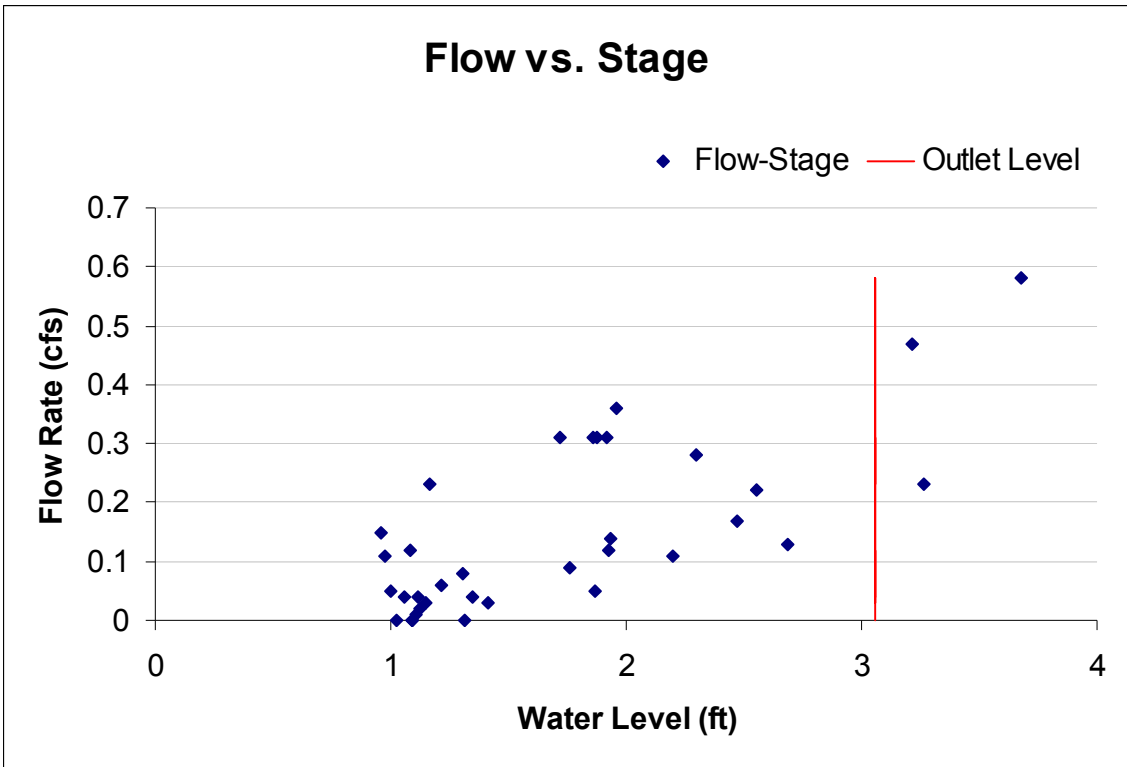

Appendix H.11: December 25, 2010 Rain Event Analysis

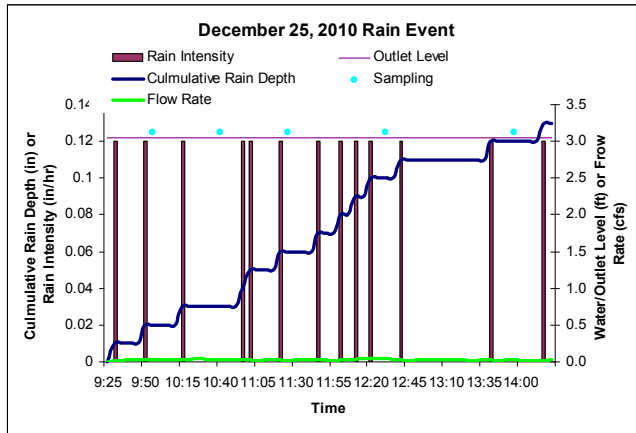

Site Information			
Site Name:	Bama Belle Parking Deck		
Site Location:	N(33°12'50") W(87°34'17")		
Drainage Area (ac):	0.9		
Percent Impervious (%):	67.8		
Runoff Curve Number	84.1		
Rational Number	0.6		
Storm Information – December 25, 2010 Storm			
	Goal	Value	QA note
Precipitation Total (in):	≥0.1	0.13	
Precipitation Duration (hr):	≥1	5.0	
Average Intensity (in/hr):	NA	0.03	
Peak Rain Intensity (in/hr):	NA	0.12	
Storm Volume (gal):	NA	3703	(0.154 in)
Maximum Discharge (cfs):	NA	0.04	
Ave Discharge Rate (cfs):	NA	0.03	
Peak to Ave Discharge Ratio:	NA	1.3	
Dry Period (hr):	≥6	≥6	
Estimated Rational Coefficient	NA	0.4	
Volumetric Runoff Coefficient	NA	1.2	

Sampling Information						
	Goal	IN	QA	Out	QA	note
Aliquots:	≥5	5		5		
% Storm:	≥75	100		100		
	Value					
Total Bypass Volume (gal):	NA					
% Bypassed to Total (%):	NA					

Analysis Information							
EMC Concentration (mg/L, CFU/100mL, #)							
	IN	note	OUT	note	MDL	note	% Conc. Reduction
TSS	91.0		35.0		NA		61.5
SSC	115.0		40.6		NA		64.7
TDS	90.0		74.2		NA		17.6
Conductivity	96.2		68.3		0 to 199,900 μS		29.0
PH	6.60		6.81		-2.00 to 19.99		-3.2
Turbidity	12.1		4.3		0 to 4000 NTU		64.4
Total COD	8		3		0 to 150 mg/L		62.5
Dissolved COD	2		1		0 to 150 mg/L		50.0
Total P	1.92		1.71		0.00 to 3.50 mg/L		10.9
Dissolved P	1.18		0.98		0.00 to 5.00 mg/L		16.9
Ammonia	0.11		0.01		0 to 2.5 mg/L		90.9
Nitrate	1.1		0.8		0 to 5.0 mg/L		27.3
Total N	4		1		0 to 2.5 mg/L		75.0
Dissolved N	2		1		0 to 2.5 mg/L		50.0
Total Zn	BDL		BDL		0.02 mg/L		-
Dissolved Zn	BDL		BDL		0.02 mg/L		-
Total Cd	BDL		BDL		0.005 mg/L		-
Dissolved Cd	BDL		BDL		0.005 mg/L		-
Total Cr	BDL		BDL		0.02 mg/L		-
Dissolved Cr	BDL		BDL		0.02 mg/L		-
Total Cu	BDL		BDL		0.02 mg/L		-
Dissolved Cu	BDL		BDL		0.02 mg/L		-
Total Pb	BDL		BDL		0.005 mg/L		-
Dissolved Pb	BDL		BDL		0.005 mg/L		-
E-Coli	2230		400		10-24196		82.1
Enterococci	1210		630		10-24196		47.9

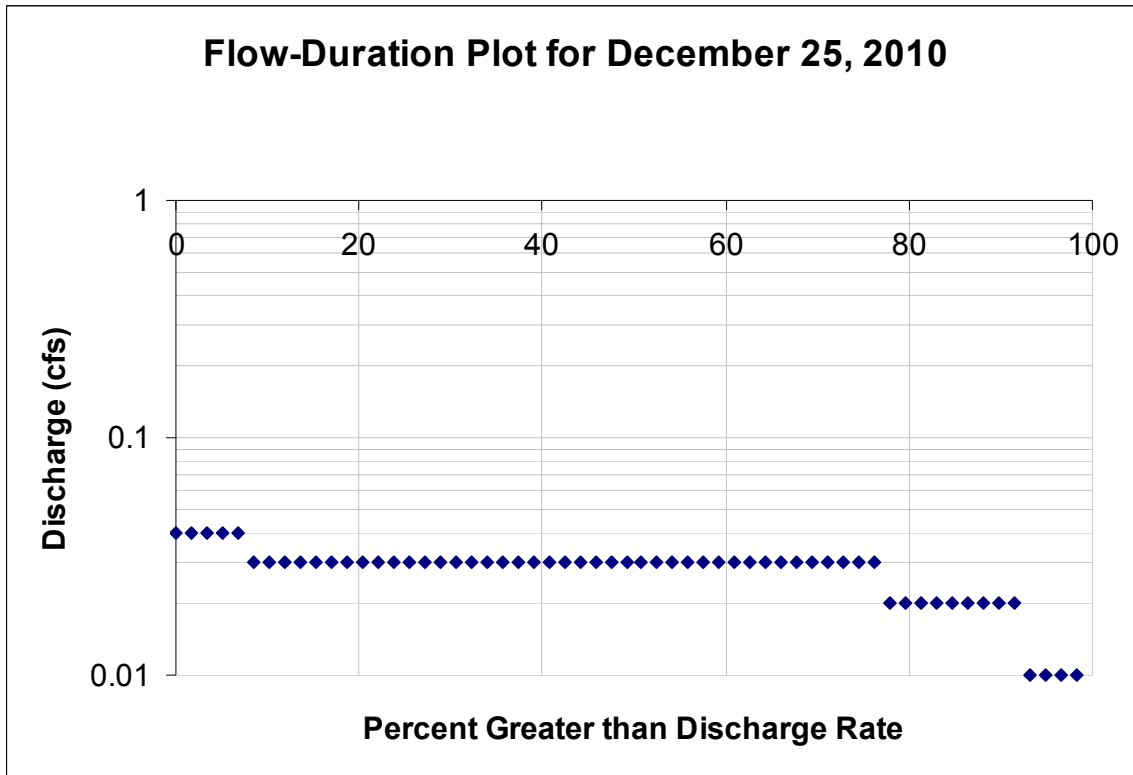
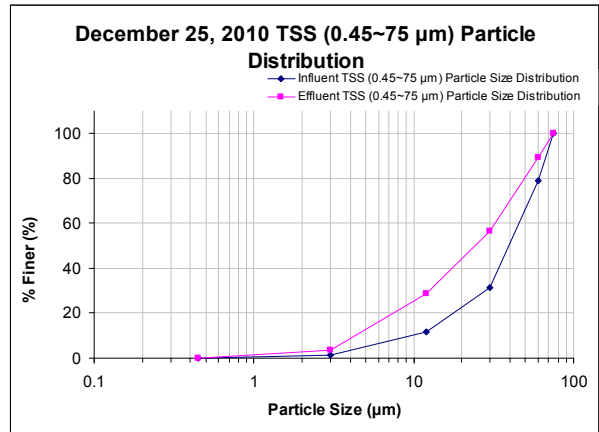
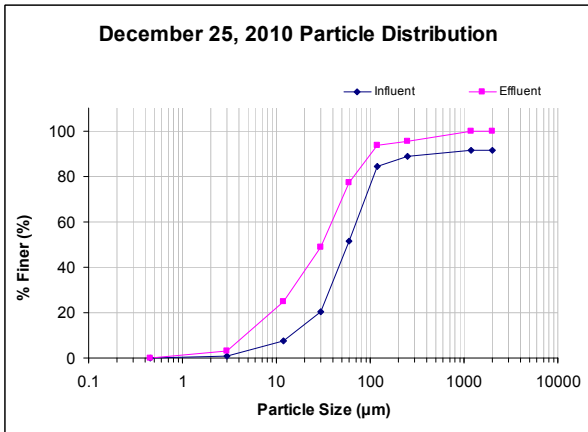

Appendix H.12: December 31, 2010 Rain Event Analysis

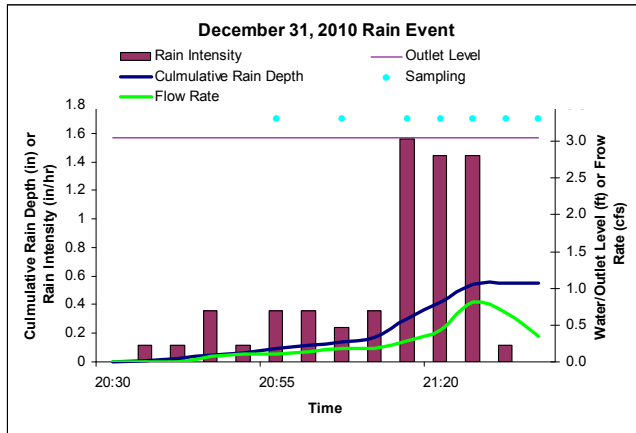

Site Information			
Site Name:	Bama Belle Parking Deck		
Site Location:	N(33°12'50") W(87°34'17")		
Drainage Area (ac):	0.9		
Percent Impervious (%):	67.8		
Runoff Curve Number	84.1		
Rational Number	0.6		
Storm Information – December 31, 2010 Storm			
	Goal	Value	QA note
Precipitation Total (in):	≥0.1	0.55	
Precipitation Duration (hr):	≥1	1.2	
Average Intensity (in/hr):	NA	0.47	
Peak Rain Intensity (in/hr):	NA	1.56	
Storm Volume (gal):	NA	7495	(0.311 in)
Maximum Discharge (cfs):	NA	0.82	
Ave Discharge Rate (cfs):	NA	0.24	
Peak to Ave Discharge Ratio:	NA	3.4	
Dry Period (hr):	≥6	≥6	
Estimated Rational Coefficient	NA	0.6	
Volumetric Runoff Coefficient	NA	0.6	

Sampling Information						
	Goal	IN	QA	Out	QA	note
Aliquots:	≥5	7		7		
% Storm:	≥75	100		100		
	Value					
Total Bypass Volume (gal):	NA					
% Bypassed to Total (%):	NA					

Analysis Information							
EMC Concentration (mg/L, CFU/100mL, #)							
	IN	note	OUT	note	MDL	note	% Conc. Reduction
TSS	65.0		12.0		NA		81.5
SSC	80.0		29.0		NA		63.8
TDS	119.0		115.8		NA		2.7
Conductivity	93.1		66.1		0 to 199,900 μS		29.0
PH	6.58		6.66		-2.00 to 19.99		-1.2
Turbidity	18.6		8.3		0 to 4000 NTU		55.6
Total COD	25		8		0 to 150 mg/L		68.0
Dissolved COD	6		4		0 to 150 mg/L		33.3
Total P	1.93		1.71		0.00 to 3.50 mg/L		11.4
Dissolved P	1.19		0.85		0.00 to 5.00 mg/L		28.6
Ammonia	0.1		0.01		0 to 2.5 mg/L		90.0
Nitrate	1.3		0.6		0 to 5.0 mg/L		53.8
Total N	5		2		0 to 2.5 mg/L		60.0
Dissolved N	2		1		0 to 2.5 mg/L		50.0
Total Zn	BDL		BDL		0.02 mg/L		-
Dissolved Zn	BDL		BDL		0.02 mg/L		-
Total Cd	BDL		BDL		0.005 mg/L		-
Dissolved Cd	BDL		BDL		0.005 mg/L		-
Total Cr	BDL		BDL		0.02 mg/L		-
Dissolved Cr	BDL		BDL		0.02 mg/L		-
Total Cu	BDL		BDL		0.02 mg/L		-
Dissolved Cu	BDL		BDL		0.02 mg/L		-
Total Pb	BDL		BDL		0.005 mg/L		-
Dissolved Pb	BDL		BDL		0.005 mg/L		-
E-Coli	2060		1320		10-24196		35.9
Enterococci	4410		2950		10-24196		33.1

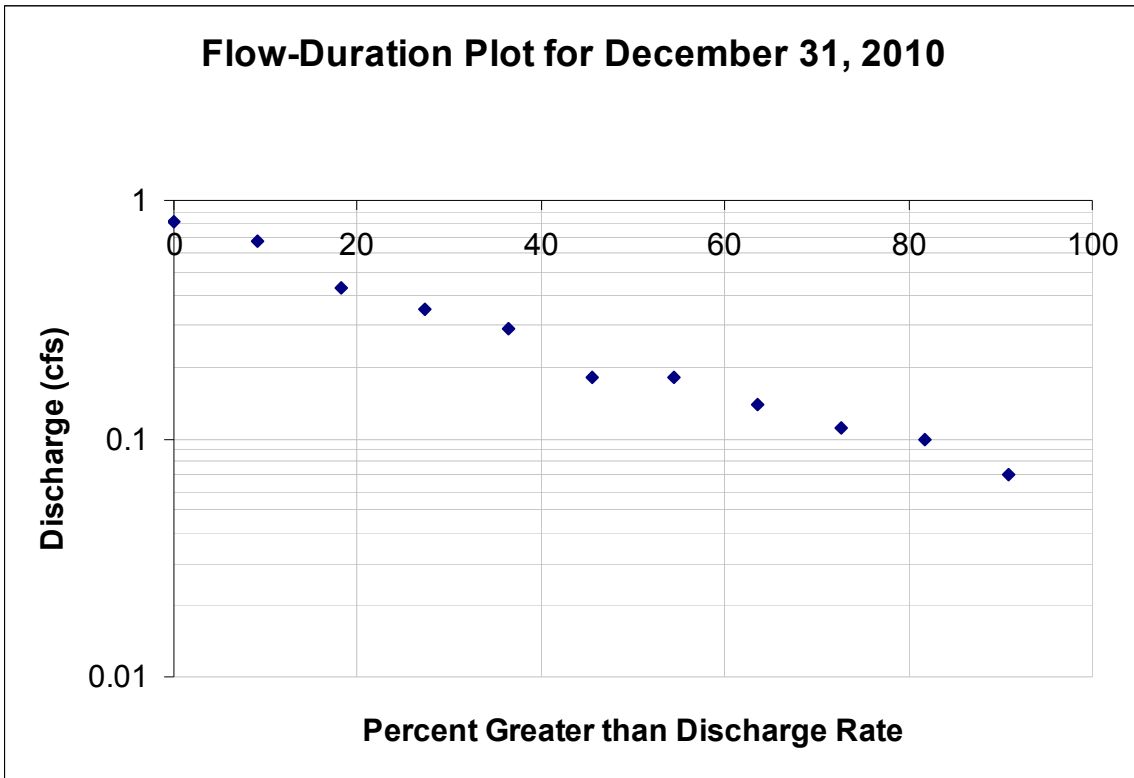
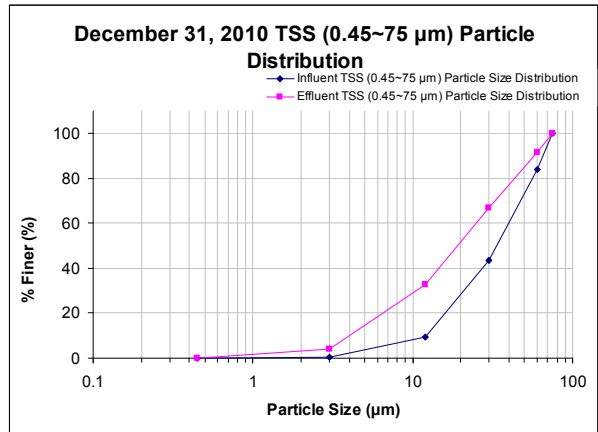
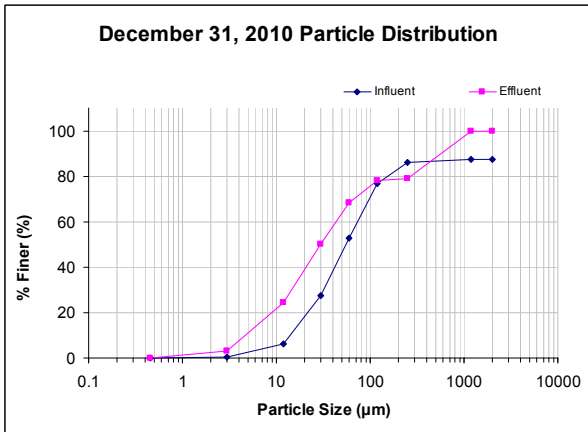

Appendix H.13: January 1, 2011 Rain Event Analysis

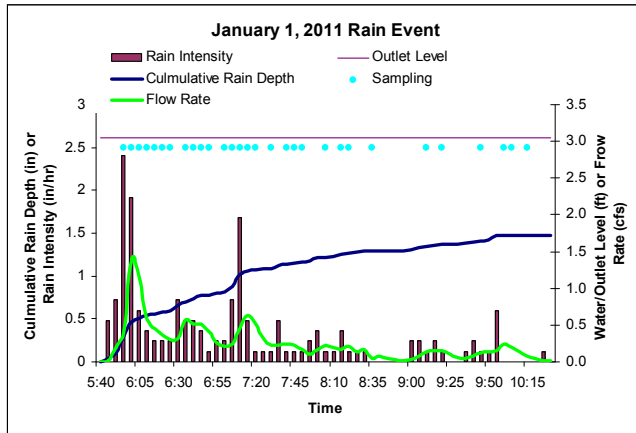

Site Information			
Site Name:	Bama Belle Parking Deck		
Site Location:	N(33°12'50") W(87°34'17")		
Drainage Area (ac):	0.9		
Percent Impervious (%):	67.8		
Runoff Curve Number	84.1		
Rational Number	0.6		
Storm Information – January 1, 2011 Storm			
	Goal	Value	QA note
Precipitation Total (in):	≥0.1	1.48	
Precipitation Duration (hr):	≥1	4.9	
Average Intensity (in/hr):	NA	0.30	
Peak Rain Intensity (in/hr):	NA	2.40	
Storm Volume (gal):	NA	32338	(1.344 in)
Maximum Discharge (cfs):	NA	1.40	
Ave Discharge Rate (cfs):	NA	0.24	
Peak to Ave Discharge Ratio:	NA	5.8	
Dry Period (hr):	≥6	≥6	
Estimated Rational Coefficient	NA	0.7	
Volumetric Runoff Coefficient	NA	0.9	

Sampling Information					
	Goal	IN	QA	Out	QA note
Aliquots:	≥5	30		30	
% Storm:	≥75	100		100	
	Value				
Total Bypass Volume (gal):	NA				
% Bypassed to Total (%):	NA				

Analysis Information							
EMC Concentration (mg/L, CFU/100mL, #)							
	IN	note	OUT	note	MDL	note	% Conc. Reduction
TSS	49.0		7.0		NA		85.7
SSC	52.0		17.0		NA		67.3
TDS	55.0		33.3		NA		39.5
Conductivity	101.5		58.1		0 to 199,900 μS		42.8
PH	7.32		7.31		-2.00 to 19.99		0.1
Turbidity	5.3		4.7		0 to 4000 NTU		12.0
Total COD	12		5		0 to 150 mg/L		58.3
Dissolved COD	7		4		0 to 150 mg/L		42.9
Total P	0.82		0.65		0.00 to 3.50 mg/L		20.7
Dissolved P	0.37		0.32		0.00 to 5.00 mg/L		13.5
Ammonia	0.06		0.05		0 to 2.5 mg/L		16.7
Nitrate	0.6		0.5		0 to 5.0 mg/L		16.7
Total N	5		4		0 to 2.5 mg/L		20.0
Dissolved N	4		3		0 to 2.5 mg/L		25.0
Total Zn	BDL		BDL		0.02 mg/L		-
Dissolved Zn	BDL		BDL		0.02 mg/L		-
Total Cd	BDL		BDL		0.005 mg/L		-
Dissolved Cd	BDL		BDL		0.005 mg/L		-
Total Cr	BDL		BDL		0.02 mg/L		-
Dissolved Cr	BDL		BDL		0.02 mg/L		-
Total Cu	BDL		BDL		0.02 mg/L		-
Dissolved Cu	BDL		BDL		0.02 mg/L		-
Total Pb	BDL		BDL		0.005 mg/L		-
Dissolved Pb	BDL		BDL		0.005 mg/L		-
E-Coli	1180		740		10-24196		37.3
Enterococci	13760		10630		10-24196		22.7

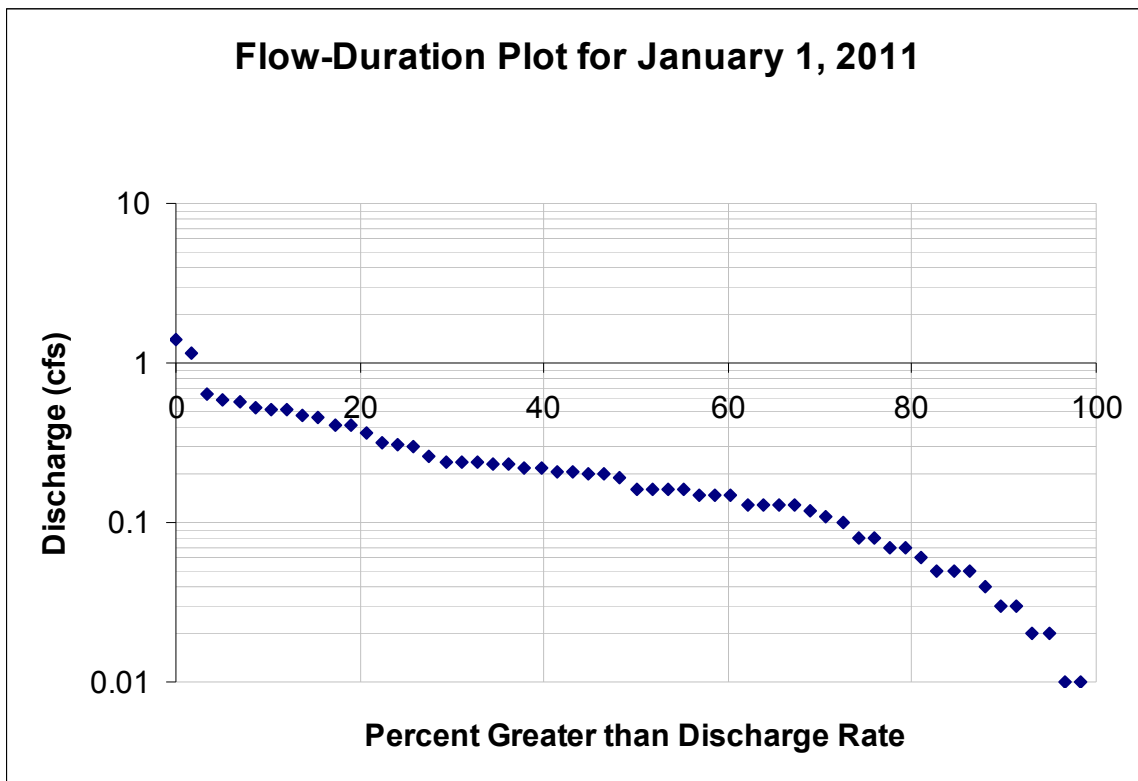
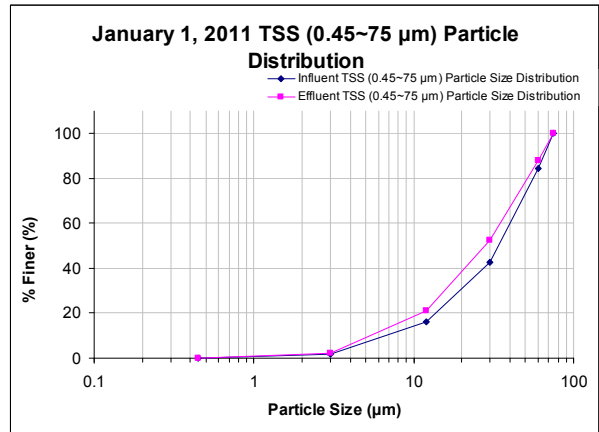
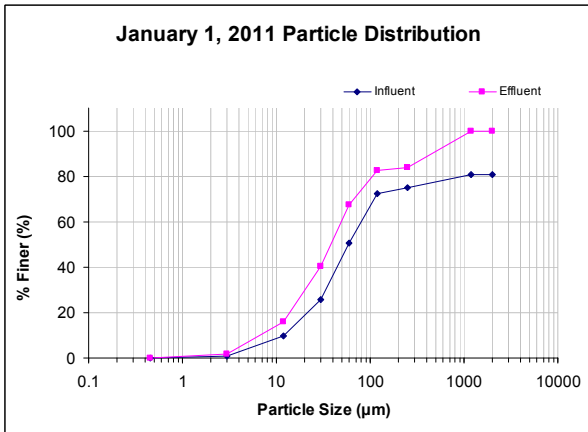

Appendix H.14: January 10, 2011 Rain Event Analysis

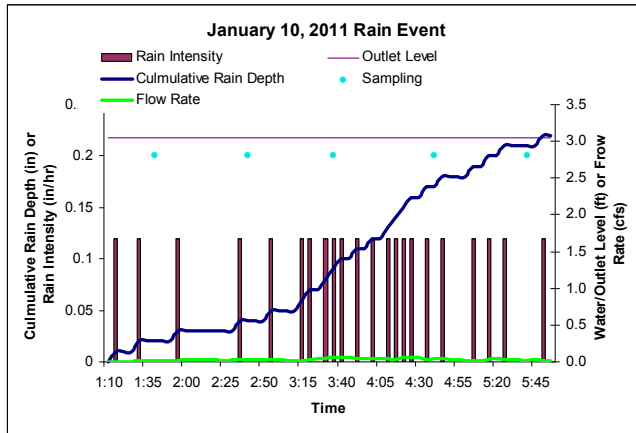

Site Information				
Site Name:	Bama Belle Parking Deck			
Site Location:	N(33°12'50") W(87°34'17")			
Drainage Area (ac):	0.9			
Percent Impervious (%):	67.8			
Runoff Curve Number	84.1			
Rational Number	0.6			
Storm Information – January 10, 2011 Storm				
	Goal	Value	QA	note
Precipitation Total (in):	≥0.1	0.22		
Precipitation Duration (hr):	≥1	4.8		
Average Intensity (in/hr):	NA	0.05		
Peak Rain Intensity (in/hr):	NA	0.12		
Storm Volume (gal):	NA	3950		(0.164 in)
Maximum Discharge (cfs):	NA	0.06		
Ave Discharge Rate (cfs):	NA	0.03		
Peak to Ave Discharge Ratio:	NA	2.0		
Dry Period (hr):	≥6	≥6		
Estimated Rational Coefficient	NA	0.6		
Volumetric Runoff Coefficient	NA	0.7		

Sampling Information						
	Goal	IN	QA	Out	QA	note
Aliquots:	≥5	5		5		
% Storm:	≥75	100		100		
	Value					
Total Bypass Volume (gal):	NA					
% Bypassed to Total (%):	NA					

Analysis Information							
EMC Concentration (mg/L, CFU/100mL, #)							
	IN	note	OUT	note	MDL	note	% Conc. Reduction
TSS	23.0		4.0		NA		82.6
SSC	29.0		6.0		NA		79.3
TDS	92.0		95.8		NA		-4.1
Conductivity	72.4		70.0		0 to 199,900 μS		3.3
PH	7.20		7.18		-2.00 to 19.99		0.3
Turbidity	8.0		2.7		0 to 4000 NTU		66.7
Total COD	89		23		0 to 150 mg/L		74.2
Dissolved COD	20		10		0 to 150 mg/L		50.0
Total P	0.74		0.69		0.00 to 3.50 mg/L		6.8
Dissolved P	0.36		0.34		0.00 to 5.00 mg/L		5.6
Ammonia	0.07		0.01		0 to 2.5 mg/L		85.7
Nitrate	0.5		0.4		0 to 5.0 mg/L		20.0
Total N	6		3		0 to 2.5 mg/L		50.0
Dissolved N	3		1		0 to 2.5 mg/L		66.7
Total Zn	BDL		BDL		0.02 mg/L		-
Dissolved Zn	BDL		BDL		0.02 mg/L		-
Total Cd	BDL		BDL		0.005 mg/L		-
Dissolved Cd	BDL		BDL		0.005 mg/L		-
Total Cr	BDL		BDL		0.02 mg/L		-
Dissolved Cr	BDL		BDL		0.02 mg/L		-
Total Cu	BDL		BDL		0.02 mg/L		-
Dissolved Cu	BDL		BDL		0.02 mg/L		-
Total Pb	BDL		BDL		0.005 mg/L		-
Dissolved Pb	BDL		BDL		0.005 mg/L		-
E-Coli	1180		610		10-24196		48.3
Enterococci	12390		11340		10-24196		8.5

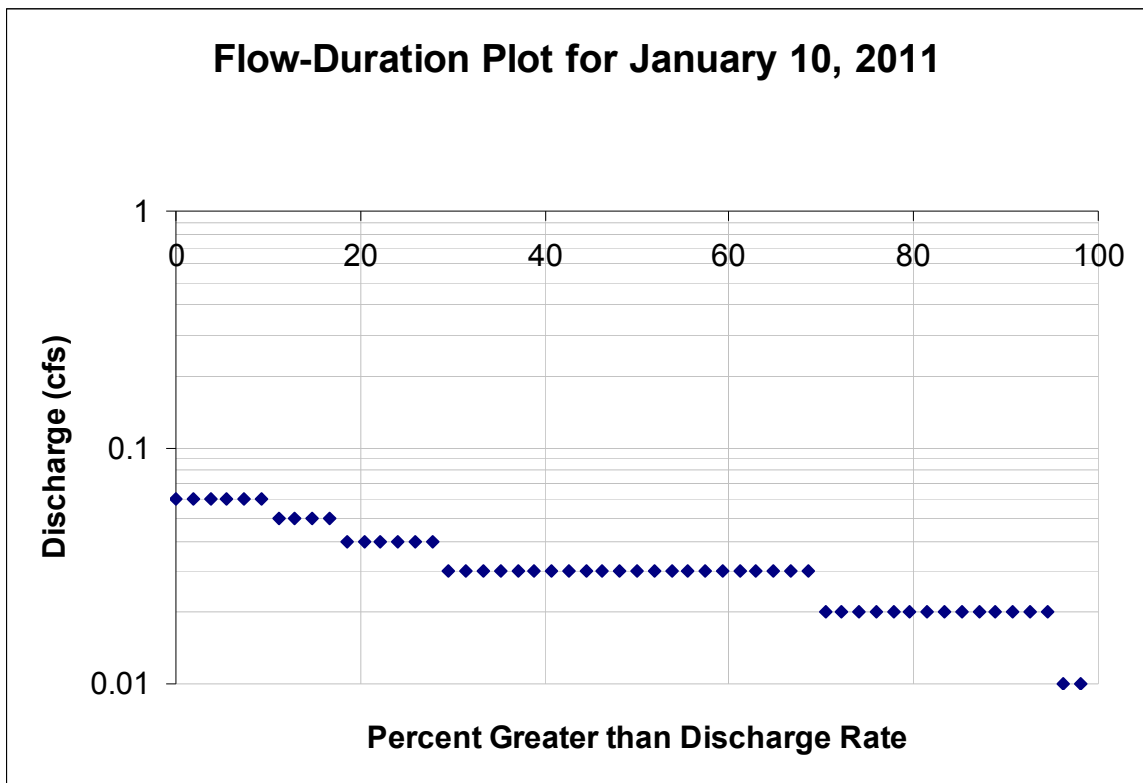
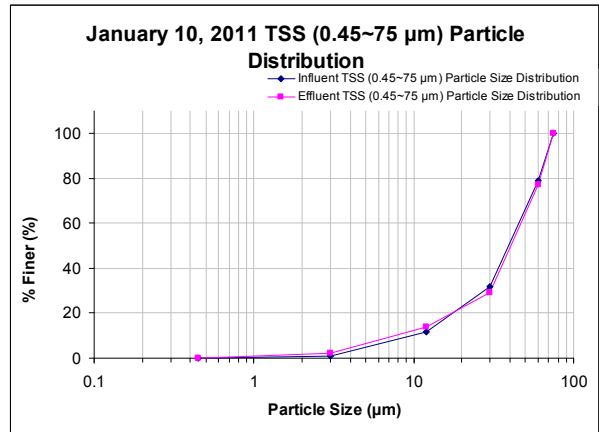
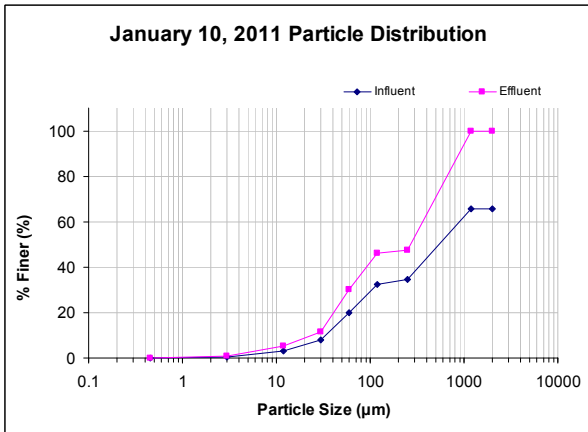

Appendix H.15: January 25, 2011 Rain Event Analysis

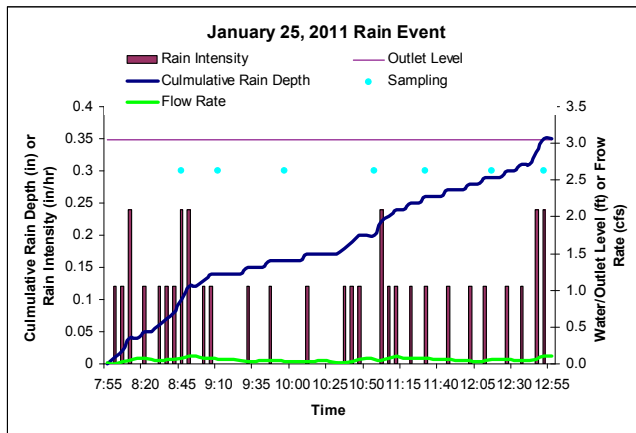

Site Information			
Site Name:	Bama Belle Parking Deck		
Site Location:	N(33°12'50") W(87°34'17")		
Drainage Area (ac):	0.9		
Percent Impervious (%):	67.8		
Runoff Curve Number	84.1		
Rational Number	0.6		
Storm Information – January 25, 2011 Storm			
	Goal	Value	QA note
Precipitation Total (in):	≥0.1	0.35	
Precipitation Duration (hr):	≥1	5.1	
Average Intensity (in/hr):	NA	0.07	
Peak Rain Intensity (in/hr):	NA	0.24	
Storm Volume (gal):	NA	7473	(0.311 in)
Maximum Discharge (cfs):	NA	0.11	
Ave Discharge Rate (cfs):	NA	0.05	
Peak to Ave Discharge Ratio:	NA	2.2	
Dry Period (hr):	≥6	≥6	
Estimated Rational Coefficient	NA	0.5	
Volumetric Runoff Coefficient	NA	0.9	

Sampling Information						
	Goal	IN	QA	Out	QA	note
Aliquots:	≥5	7		7		
% Storm:	≥75	100		100		
		Value				
Total Bypass Volume (gal):	NA					
% Bypassed to Total (%):	NA					

Analysis Information						
EMC Concentration (mg/L, CFU/100mL, #)						
	IN	note	OUT	note	MDL	note
						% Conc. Reduction
TSS	40.0		13.0		NA	67.5
SSC	43.0		17.9		NA	58.4
TDS	106.0		54.2		NA	48.9
Conductivity	80.3		76.2		0 to 199,900 μS	5.1
PH	7.14		7.10		-2.00 to 19.99	0.6
Turbidity	20.0		9.4		0 to 4000 NTU	53.0
Total COD	85		14		0 to 150 mg/L	83.5
Dissolved COD	59		11		0 to 150 mg/L	81.4
Total P	1.62		0.90		0.00 to 3.50 mg/L	44.4
Dissolved P	0.41		0.40		0.00 to 5.00 mg/L	2.4
Ammonia	0.12		0.07		0 to 2.5 mg/L	41.7
Nitrate	0.9		0.8		0 to 5.0 mg/L	11.1
Total N	4		2		0 to 2.5 mg/L	50.0
Dissolved N	3		1		0 to 2.5 mg/L	66.7
Total Zn	BDL		BDL		0.02 mg/L	-
Dissolved Zn	BDL		BDL		0.02 mg/L	-
Total Cd	BDL		BDL		0.005 mg/L	-
Dissolved Cd	BDL		BDL		0.005 mg/L	-
Total Cr	BDL		BDL		0.02 mg/L	-
Dissolved Cr	BDL		BDL		0.02 mg/L	-
Total Cu	BDL		BDL		0.02 mg/L	-
Dissolved Cu	BDL		BDL		0.02 mg/L	-
Total Pb	BDL		BDL		0.005 mg/L	-
Dissolved Pb	BDL		BDL		0.005 mg/L	-
E-Coli	960		740		10-24196	22.9
Enterococci	10580		10190		10-24196	3.7

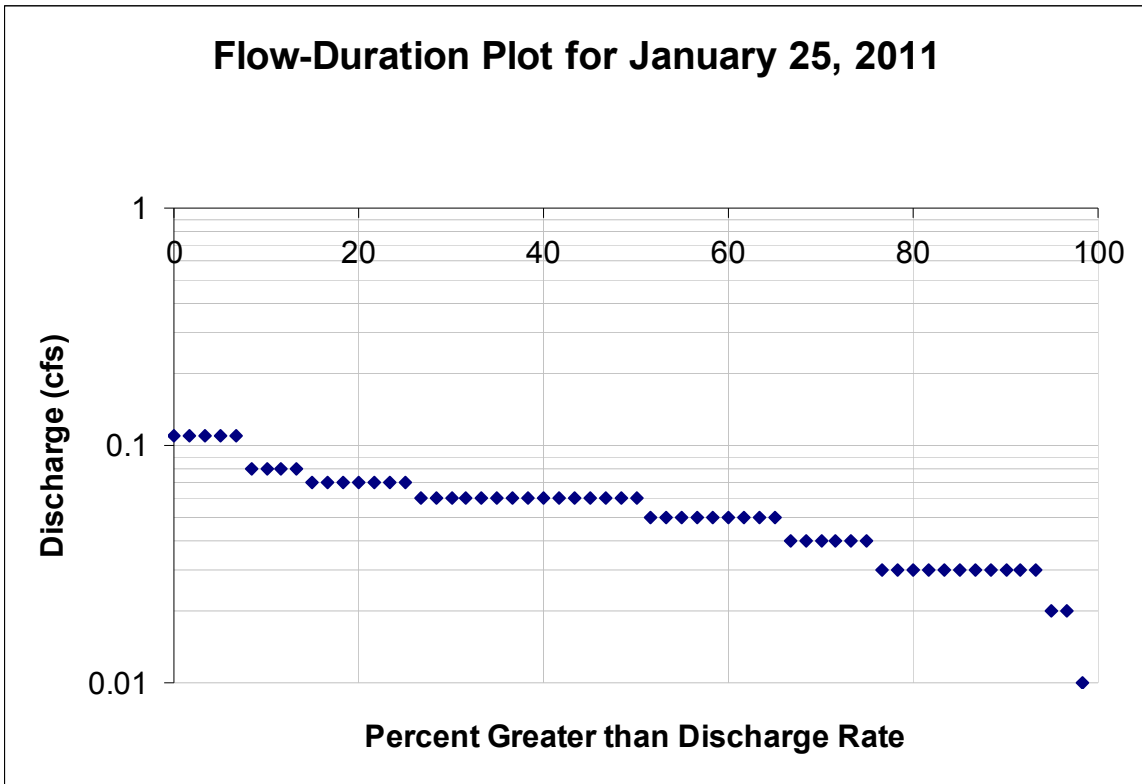
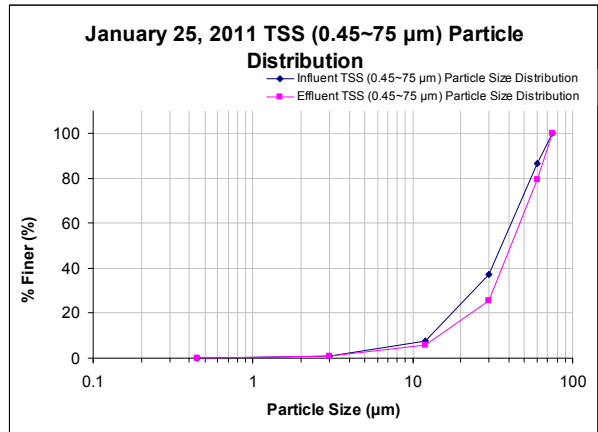
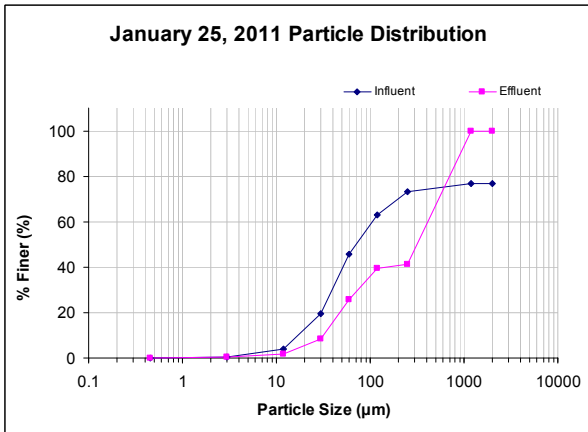

Appendix H.16: February 25, 2011 Rain Event Analysis

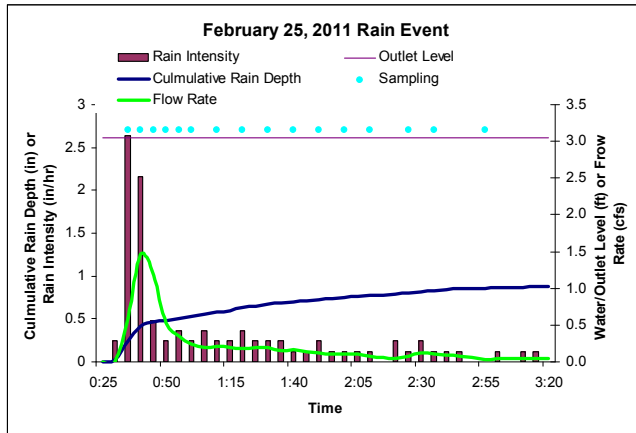

Site Information			
Site Name:	Bama Belle Parking Deck		
Site Location:	N(33°12'50") W(87°34'17")		
Drainage Area (ac):	0.9		
Percent Impervious (%):	67.8		
Runoff Curve Number	84.1		
Rational Number	0.6		
Storm Information – February 25, 2011 Storm			
	Goal	Value	QA note
Precipitation Total (in):	≥0.1	0.88	
Precipitation Duration (hr):	≥1	3.0	
Average Intensity (in/hr):	NA	0.29	
Peak Rain Intensity (in/hr):	NA	2.64	
Storm Volume (gal):	NA	16472	(0.684 in)
Maximum Discharge (cfs):	NA	1.46	
Ave Discharge Rate (cfs):	NA	0.20	
Peak to Ave Discharge Ratio:	NA	7.3	
Dry Period (hr):	≥6	≥6	
Estimated Rational Coefficient	NA	0.6	
Volumetric Runoff Coefficient	NA	0.8	

Sampling Information					
	Goal	IN	QA	Out	QA note
Aliquots:	≥5	16		16	
% Storm:	≥75	100		100	
	Value				
Total Bypass Volume (gal):	NA				
% Bypassed to Total (%):	NA				

Analysis Information							
EMC Concentration (mg/L, CFU/100mL, #)							
	IN	note	OUT	note	MDL	note	% Conc. Reduction
TSS	15.0		7.0		NA		53.3
SSC	27.0		6.3		NA		76.7
TDS	29.0		11.7		NA		59.7
Conductivity	50.7		37.4		0 to 199,900 μS		26.2
PH	7.22		7.23		-2.00 to 19.99		-0.1
Turbidity	8.9		5.9		0 to 4000 NTU		33.7
Total COD	6		3		0 to 150 mg/L		50.0
Dissolved COD	3		2		0 to 150 mg/L		33.3
Total P	0.71		0.62		0.00 to 3.50 mg/L		12.7
Dissolved P	0.38		0.30		0.00 to 5.00 mg/L		21.1
Ammonia	0.02		0.02		0 to 2.5 mg/L		0
Nitrate	0.5		0.4		0 to 5.0 mg/L		20.0
Total N	3		2		0 to 2.5 mg/L		33.3
Dissolved N	2		1		0 to 2.5 mg/L		50.0
Total Zn	BDL		BDL		0.02 mg/L		-
Dissolved Zn	BDL		BDL		0.02 mg/L		-
Total Cd	BDL		BDL		0.005 mg/L		-
Dissolved Cd	BDL		BDL		0.005 mg/L		-
Total Cr	BDL		BDL		0.02 mg/L		-
Dissolved Cr	BDL		BDL		0.02 mg/L		-
Total Cu	BDL		BDL		0.02 mg/L		-
Dissolved Cu	BDL		BDL		0.02 mg/L		-
Total Pb	BDL		BDL		0.005 mg/L		-
Dissolved Pb	BDL		BDL		0.005 mg/L		-
E-Coli	1090		620		10-24196		43.1
Enterococci	15530		10170		10-24196		34.5

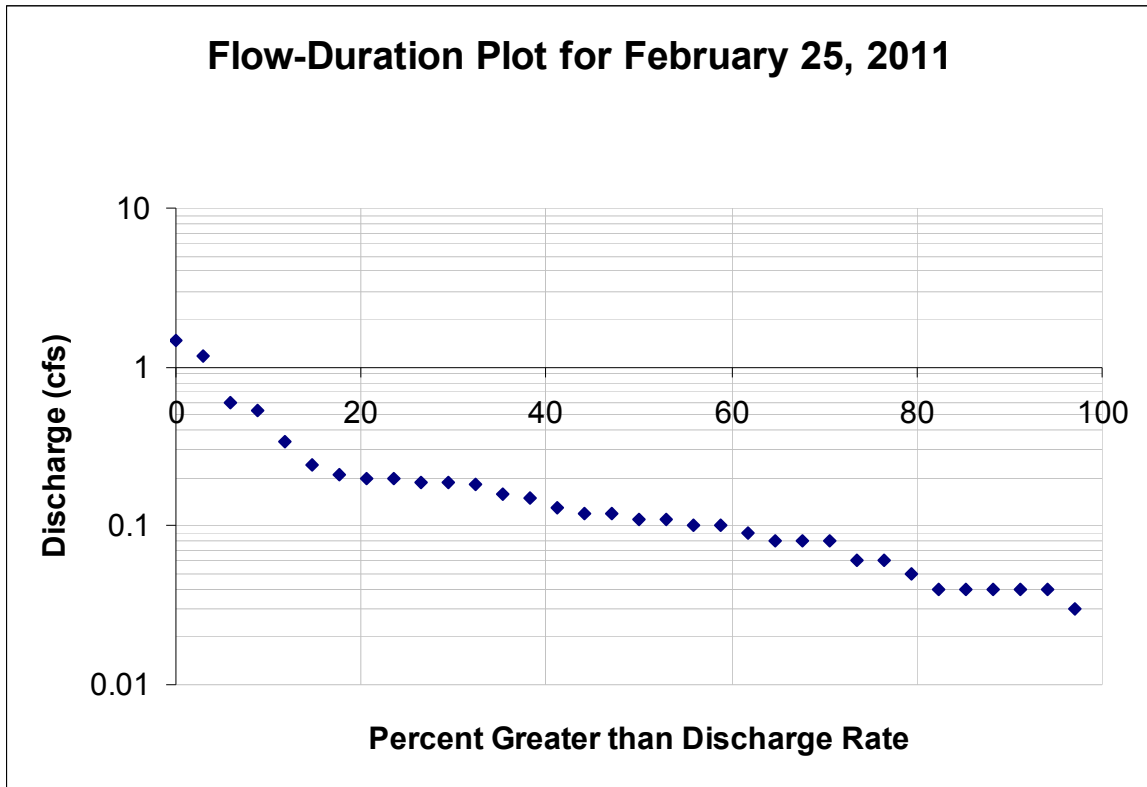
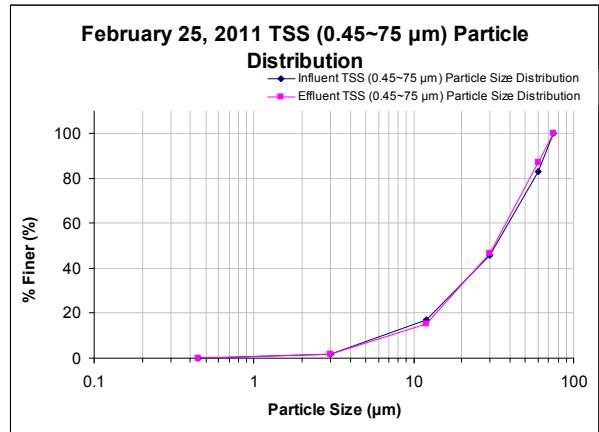
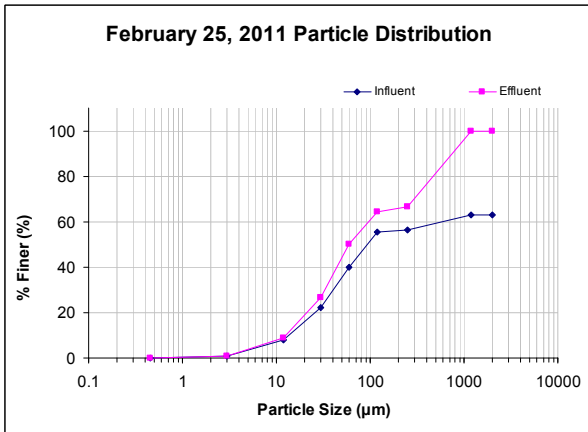

Appendix H.17: March 4, 2011 Rain Event Analysis

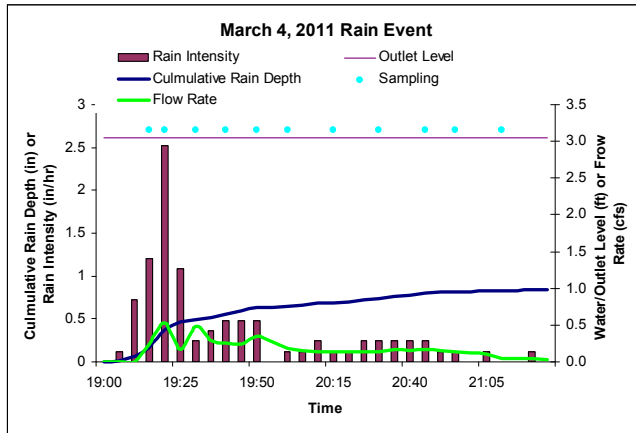

Site Information				
Site Name:	Bama Belle Parking Deck			
Site Location:	N(33°12'50") W(87°34'17")			
Drainage Area (ac):	0.9			
Percent Impervious (%):	67.8			
Runoff Curve Number	84.1			
Rational Number	0.6			
Storm Information – March 4, 2011 Storm				
	Goal	Value	QA	note
Precipitation Total (in):	≥0.1	0.84		
Precipitation Duration (hr):	≥1	2.5		
Average Intensity (in/hr):	NA	0.34		
Peak Rain Intensity (in/hr):	NA	2.52		
Storm Volume (gal):	NA	11176		(0.464 in)
Maximum Discharge (cfs):	NA	0.53		
Ave Discharge Rate (cfs):	NA	0.34		
Peak to Ave Discharge Ratio:	NA	1.6		
Dry Period (hr):	≥6	≥6		
Estimated Rational Coefficient	NA	0.2		
Volumetric Runoff Coefficient	NA	0.6		

Sampling Information					
	Goal	IN	QA	Out	QA note
Aliquots:	≥5	11		11	
% Storm:	≥75	100		100	
	Value				
Total Bypass Volume (gal):	NA				
% Bypassed to Total (%):	NA				

Analysis Information							
EMC Concentration (mg/L, CFU/100mL, #)							
	IN	note	OUT	note	MDL	note	% Conc. Reduction
TSS	30.0		16.0		NA		46.7
SSC	33.0		11.6		NA		64.8
TDS	106.0		107.5		NA		-1.4
Conductivity	343		200		0 to 199,900 μS		41.7
PH	6.89		6.85		-2.00 to 19.99		0.6
Turbidity	6.5		3.9		0 to 4000 NTU		39.5
Total COD	23		19		0 to 150 mg/L		17.4
Dissolved COD	18		11		0 to 150 mg/L		38.9
Total P	0.69		0.59		0.00 to 3.50 mg/L		14.5
Dissolved P	0.26		0.13		0.00 to 5.00 mg/L		50.0
Dissolved TP	0.61		0.56		0.00 to 3.50 mg/L		8.2
Ammonia	0.09		0.05		0 to 2.5 mg/L		44.4
Nitrate	0.8		0.7		0 to 5.0 mg/L		12.5
Total N	3		1		0 to 2.5 mg/L		66.7
Dissolved N	2		1		0 to 2.5 mg/L		50.0
Total Zn	BDL		BDL		0.02 mg/L		-
Dissolved Zn	BDL		BDL		0.02 mg/L		-
Total Cd	BDL		BDL		0.005 mg/L		-
Dissolved Cd	BDL		BDL		0.005 mg/L		-
Total Cr	BDL		BDL		0.02 mg/L		-
Dissolved Cr	BDL		BDL		0.02 mg/L		-
Total Cu	BDL		BDL		0.02 mg/L		-
Dissolved Cu	BDL		BDL		0.02 mg/L		-
Total Pb	BDL		BDL		0.005 mg/L		-
Dissolved Pb	BDL		BDL		0.005 mg/L		-
E-Coli	630		310		10-24196		50.8
Enterococci	15390		10920		10-24196		29.0

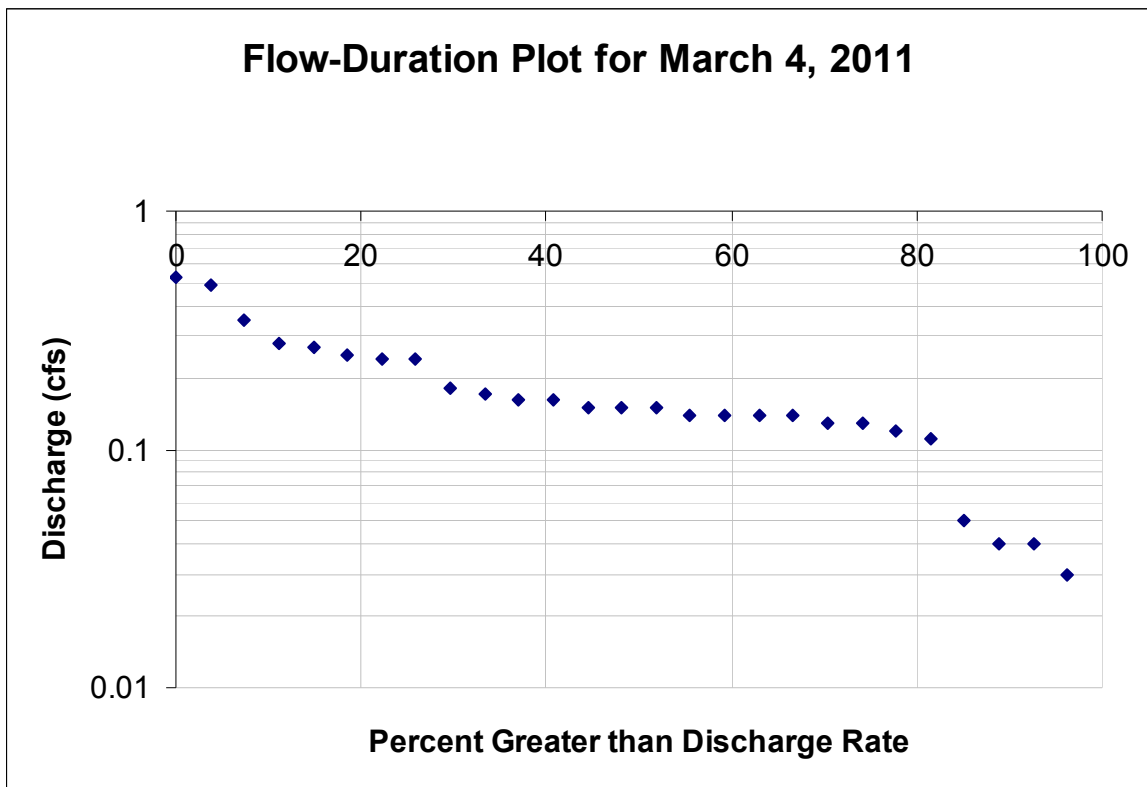
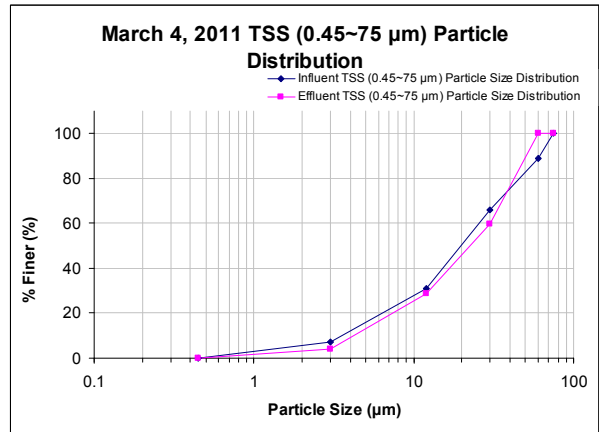
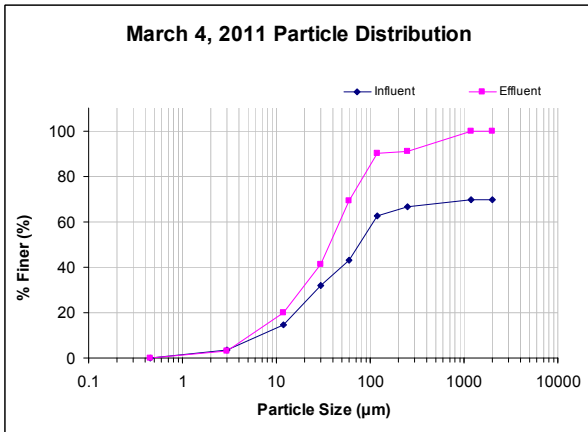

Appendix H.18: March 28, 2011 Rain Event Analysis

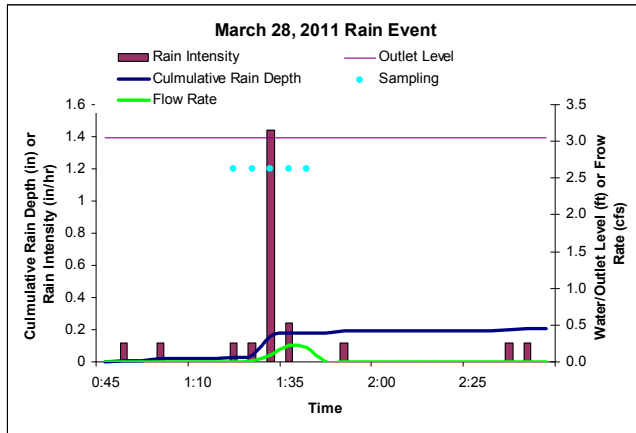

Site Information			
Site Name:	Bama Belle Parking Deck		
Site Location:	N(33°12'50") W(87°34'17")		
Drainage Area (ac):	0.9		
Percent Impervious (%):	67.8		
Runoff Curve Number	84.1		
Rational Number	0.6		
Storm Information – March 28, 2011 Storm			
	Goal	Value	QA note
Precipitation Total (in):	≥0.1	0.21	
Precipitation Duration (hr):	≥1	2.1	
Average Intensity (in/hr):	NA	0.1	
Peak Rain Intensity (in/hr):	NA	1.44	
Storm Volume (gal):	NA	1145	(0.048 in)
Maximum Discharge (cfs):	NA	0.22	
Ave Discharge Rate (cfs):	NA	0.02	
Peak to Ave Discharge Ratio:	NA	11.0	
Dry Period (hr):	≥6	≥6	
Estimated Rational Coefficient	NA	0.2	
Volumetric Runoff Coefficient	NA	0.2	

Sampling Information						
	Goal	IN	QA	Out	QA	note
Aliquots:	≥5	5		5		
% Storm:	≥75	100		100		
	Value					
Total Bypass Volume (gal):	NA					
% Bypassed to Total (%):	NA					

Analysis Information							
EMC Concentration (mg/L, CFU/100mL, #)							
	IN	note	OUT	note	MDL	note	% Conc. Reduction
TSS	27.0		21.0		NA		22.2
SSC	24.0		21.1		NA		12.1
TDS	91.0		75.8		NA		16.7
Conductivity	119.8		59.0		0 to 199,900 μS		50.8
PH	7.35		7.69		-2.00 to 19.99		-4.6
Turbidity	10.0		7.2		0 to 4000 NTU		27.9
Total COD	8		4		0 to 150 mg/L		50.0
Dissolved COD	4		2		0 to 150 mg/L		50.0
Total P	0.65		0.57		0.00 to 3.50 mg/L		12.3
Dissolved P	0.24		0.22		0.00 to 5.00 mg/L		8.3
Dissolved TP	0.55		0.49		0.00 to 3.50 mg/L		10.9
Ammonia	0.08		0.03		0 to 2.5 mg/L		62.5
Nitrate	0.6		0.5		0 to 5.0 mg/L		16.7
Total N	3		2		0 to 2.5 mg/L		33.3
Dissolved N	2		1		0 to 2.5 mg/L		50.0
Total Zn	BDL		BDL		0.02 mg/L		-
Dissolved Zn	BDL		BDL		0.02 mg/L		-
Total Cd	BDL		BDL		0.005 mg/L		-
Dissolved Cd	BDL		BDL		0.005 mg/L		-
Total Cr	BDL		BDL		0.02 mg/L		-
Dissolved Cr	BDL		BDL		0.02 mg/L		-
Total Cu	BDL		BDL		0.02 mg/L		-
Dissolved Cu	BDL		BDL		0.02 mg/L		-
Total Pb	BDL		BDL		0.005 mg/L		-
Dissolved Pb	BDL		BDL		0.005 mg/L		-
E-Coli	730		410		10-24196		43.8
Enterococci	16580		13310		10-24196		19.7

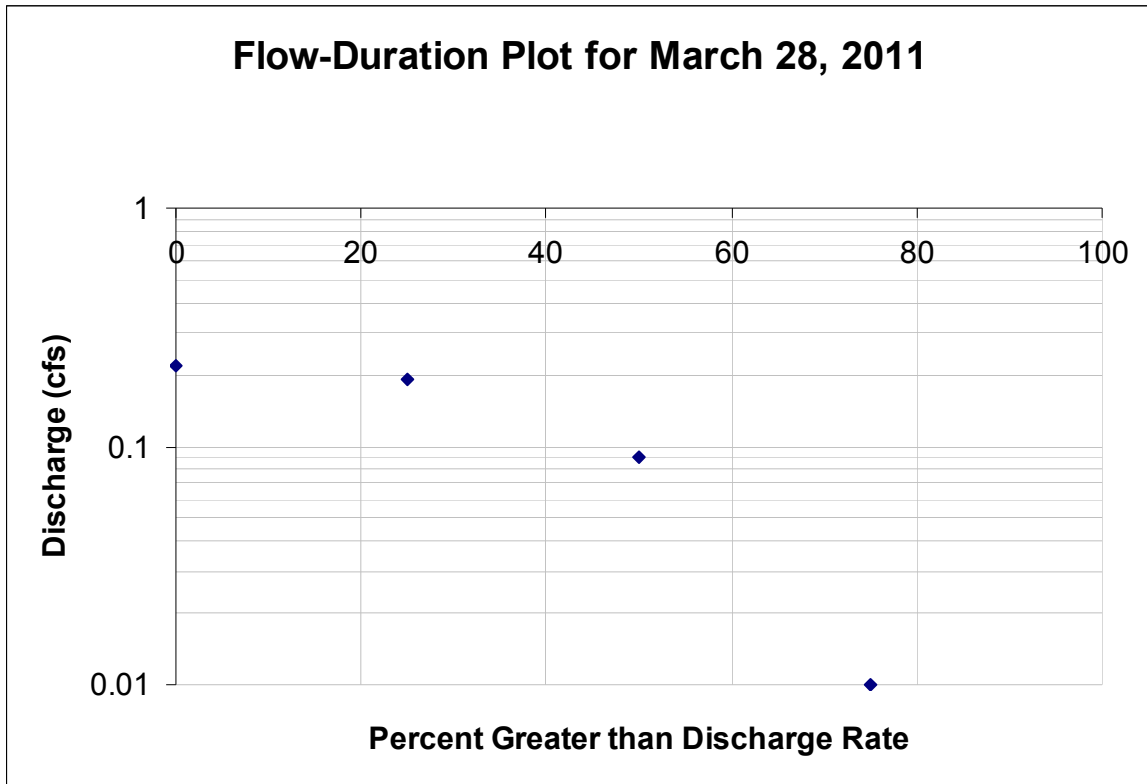
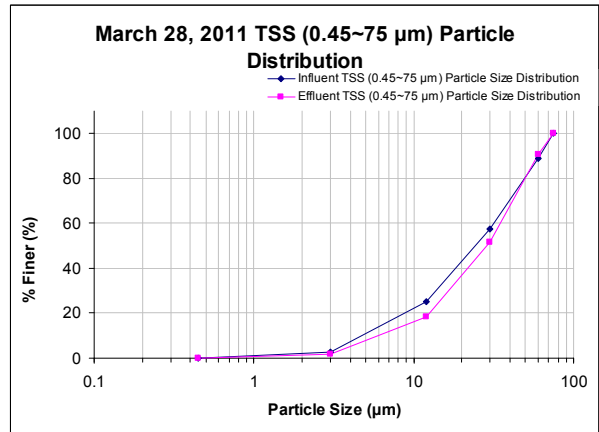
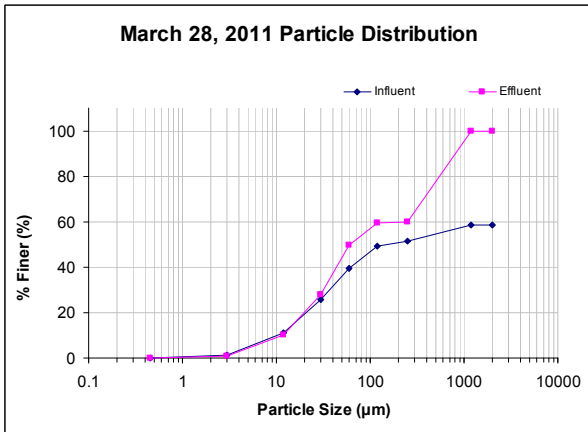

Appendix H.19: March 29, 2011 Rain Event Analysis

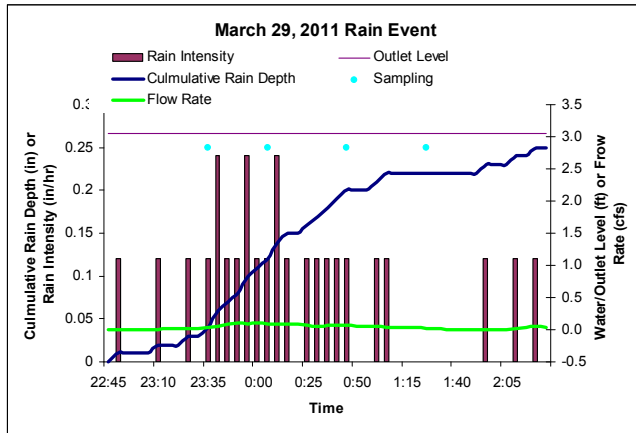

Site Information			
Site Name:	Bama Belle Parking Deck		
Site Location:	N(33°12'50") W(87°34'17")		
Drainage Area (ac):	0.9		
Percent Impervious (%):	67.8		
Runoff Curve Number	84.1		
Rational Number	0.6		
Storm Information – March 29, 2011 Storm			
	Goal	Value	QA note
Precipitation Total (in):	≥0.1	0.25	
Precipitation Duration (hr):	≥1	3.8	
Average Intensity (in/hr):	NA	0.07	
Peak Rain Intensity (in/hr):	NA	0.24	
Storm Volume (gal):	NA	3793	(0.158 in)
Maximum Discharge (cfs):	NA	0.35	
Ave Discharge Rate (cfs):	NA	0.08	
Peak to Ave Discharge Ratio:	NA	0.23	
Dry Period (hr):	≥6	≥6	
Estimated Rational Coefficient	NA	0.5	
Volumetric Runoff Coefficient	NA	0.6	

Sampling Information						
	Goal	IN	QA	Out	QA	note
Aliquots:	≥5	4		4		
% Storm:	≥75	100		100		
	Value					
Total Bypass Volume (gal):	NA					
% Bypassed to Total (%):	NA					

Analysis Information							
EMC Concentration (mg/L, CFU/100mL, #)							
	IN	note	OUT	note	MDL	note	% Conc. Reduction
TSS	42.0		13.0		NA		69.0
SSC	37.0		11.6		NA		68.6
TDS	59.0		28.3		NA		52.0
Conductivity	69.2		61.0		0 to 199,900 μS		11.8
PH	7.21		7.42		-2.00 to 19.99		-2.9
Turbidity	15.7		7.2		0 to 4000 NTU		54.1
Total COD	26		18		0 to 150 mg/L		30.8
Dissolved COD	15		11		0 to 150 mg/L		26.7
Total P	0.76		0.62		0.00 to 3.50 mg/L		18.4
Dissolved P	0.23		0.12		0.00 to 5.00 mg/L		47.8
Dissolved TP	0.61		0.58		0.00 to 3.50 mg/L		4.9
Ammonia	0.05		0.01		0 to 2.5 mg/L		80.0
Nitrate	0.5		0.4		0 to 5.0 mg/L		20.0
Total N	3		2		0 to 2.5 mg/L		33.3
Dissolved N	2		1		0 to 2.5 mg/L		50.0
Total Zn	BDL		BDL		0.02 mg/L		-
Dissolved Zn	BDL		BDL		0.02 mg/L		-
Total Cd	BDL		BDL		0.005 mg/L		-
Dissolved Cd	BDL		BDL		0.005 mg/L		-
Total Cr	BDL		BDL		0.02 mg/L		-
Dissolved Cr	BDL		BDL		0.02 mg/L		-
Total Cu	BDL		BDL		0.02 mg/L		-
Dissolved Cu	BDL		BDL		0.02 mg/L		-
Total Pb	BDL		BDL		0.005 mg/L		-
Dissolved Pb	BDL		BDL		0.005 mg/L		-
E-Coli	8450		6290		10-24196		25.6
Enterococci	3110		1790		10-24196		42.4

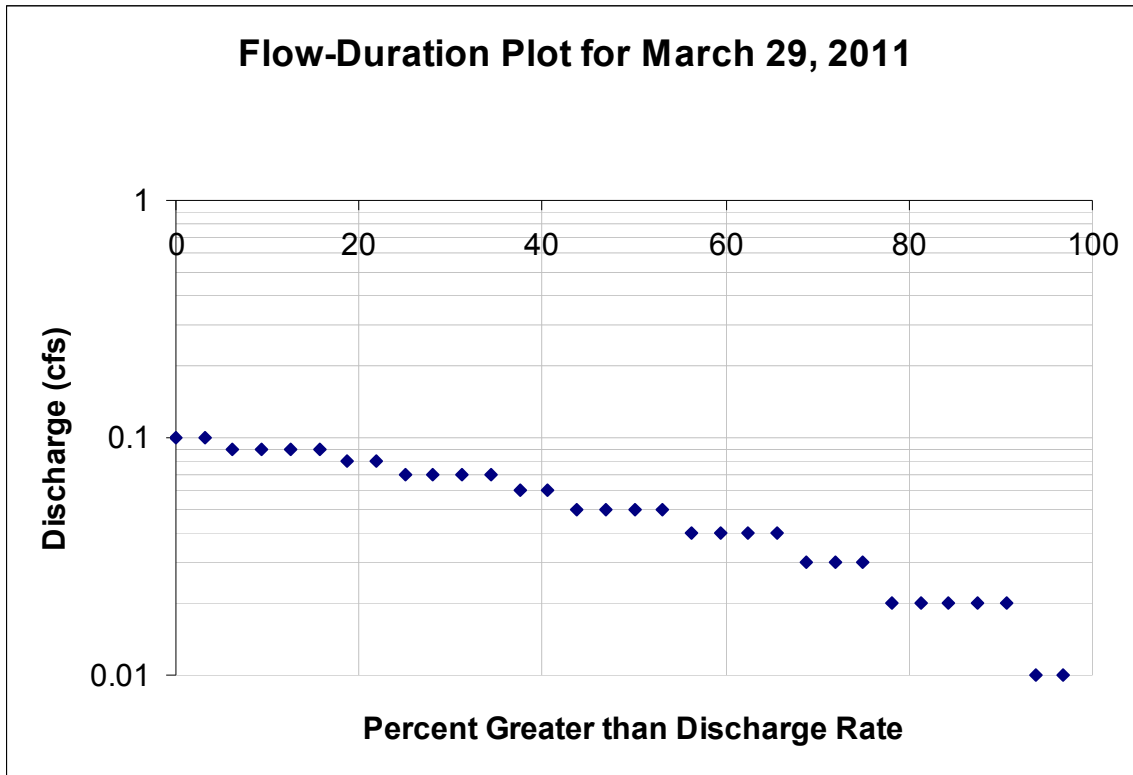
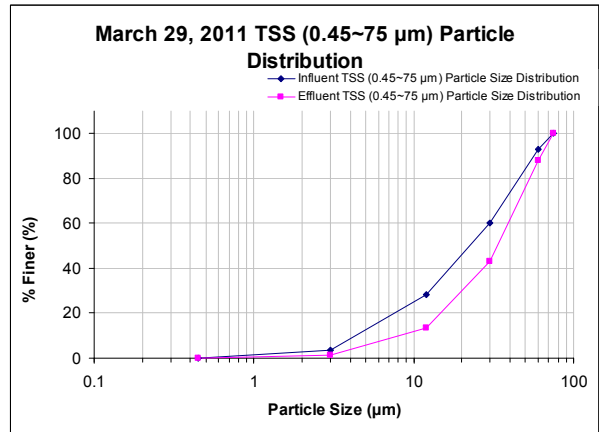
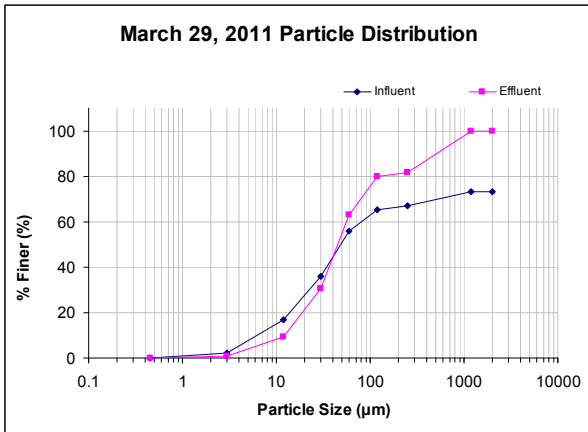

Appendix H.20: April 11, 2011 Rain Event Analysis

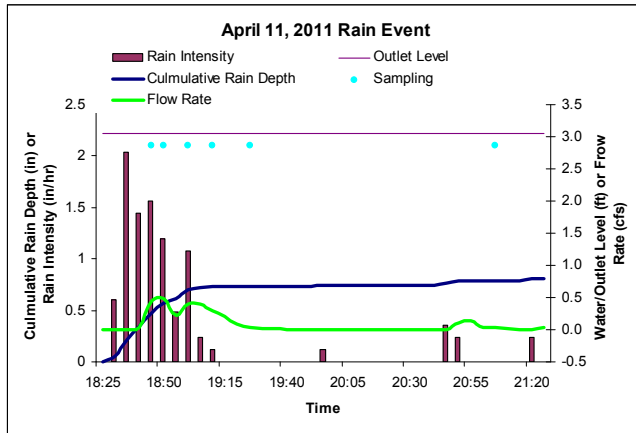

Site Information			
Site Name:	Bama Belle Parking Deck		
Site Location:	N(33°12'50") W(87°34'17")		
Drainage Area (ac):	0.9		
Percent Impervious (%):	67.8		
Runoff Curve Number	84.1		
Rational Number	0.6		
Storm Information – April 11, 2011 Storm			
	Goal	Value	QA note
Precipitation Total (in):	≥0.1	0.81	
Precipitation Duration (hr):	≥1	3.1	
Average Intensity (in/hr):	NA	0.26	
Peak Rain Intensity (in/hr):	NA	2.04	
Storm Volume (gal):	NA	6643	(0.276 in)
Maximum Discharge (cfs):	NA	0.48	
Ave Discharge Rate (cfs):	NA	0.08	
Peak to Ave Discharge Ratio:	NA	6.0	
Dry Period (hr):	≥6	≥6	
Estimated Rational Coefficient	NA	0.3	
Volumetric Runoff Coefficient	NA	0.3	

Sampling Information						
	Goal	IN	QA	Out	QA	note
Aliquots:	≥5	6		6		
% Storm:	≥75	100		100		
		Value				
Total Bypass Volume (gal):	NA					
% Bypassed to Total (%):	NA					

Analysis Information							
EMC Concentration (mg/L, CFU/100mL, #)							
	IN	note	OUT	note	MDL	note	% Conc. Reduction
TSS	115.0		64.0		NA		44.3
SSC	101.0		69.0		NA		31.7
TDS	106.0		90.8		NA		14.3
Conductivity	79.6		67.1		0 to 199,900 μS		15.7
PH	7.39		7.24		-2.00 to 19.99		2.0
Turbidity	18.9		10.0		0 to 4000 NTU		47.1
Total COD	45		29		0 to 150 mg/L		35.6
Dissolved COD	25		19		0 to 150 mg/L		24.0
Total P	0.86		0.72		0.00 to 3.50 mg/L		16.3
Dissolved P	0.28		0.19		0.00 to 5.00 mg/L		32.1
Dissolved TP	0.71		0.59		0.00 to 3.50 mg/L		16.9
Ammonia	0.06		0.04		0 to 2.5 mg/L		33.3
Nitrate	0.7		0.4		0 to 5.0 mg/L		42.9
Total N	3		2		0 to 2.5 mg/L		33.3
Dissolved N	2		1		0 to 2.5 mg/L		50.0
Total Zn	BDL		BDL		0.02 mg/L		-
Dissolved Zn	BDL		BDL		0.02 mg/L		-
Total Cd	BDL		BDL		0.005 mg/L		-
Dissolved Cd	BDL		BDL		0.005 mg/L		-
Total Cr	BDL		BDL		0.02 mg/L		-
Dissolved Cr	BDL		BDL		0.02 mg/L		-
Total Cu	BDL		BDL		0.02 mg/L		-
Dissolved Cu	BDL		BDL		0.02 mg/L		-
Total Pb	BDL		BDL		0.005 mg/L		-
Dissolved Pb	BDL		BDL		0.005 mg/L		-
E-Coli	11190		8620		10-24196		23.0
Enterococci	2260		1340		10-24196		40.7

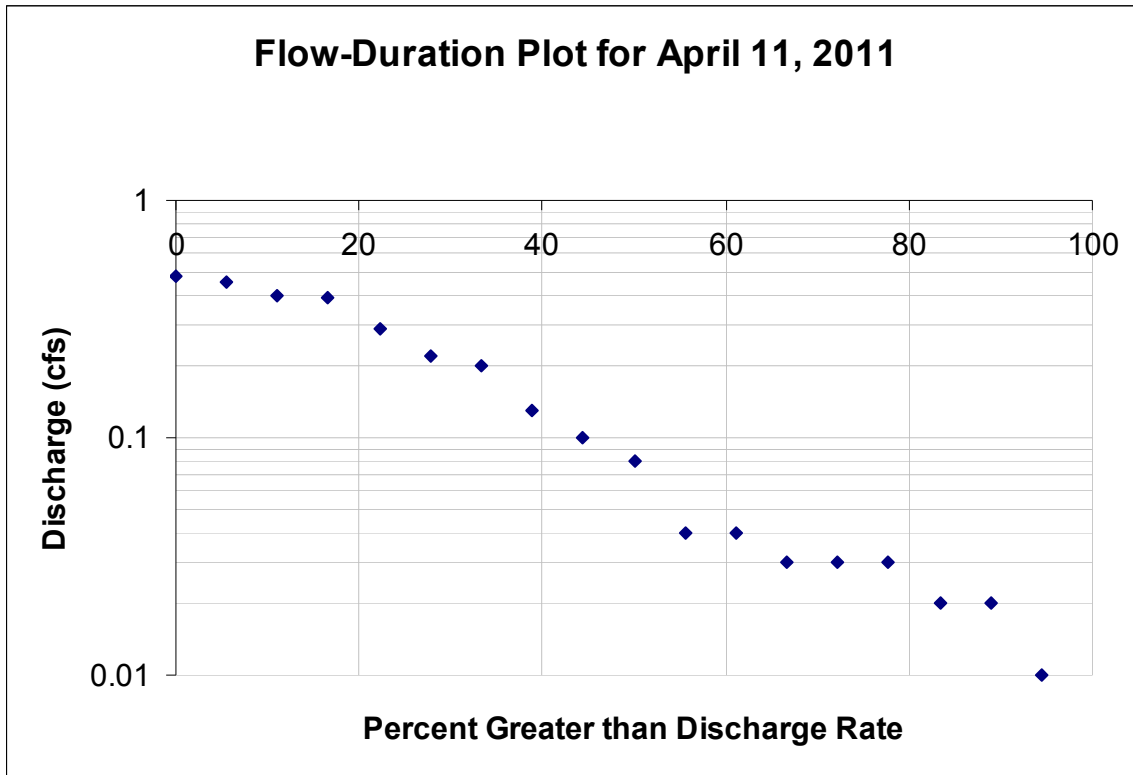
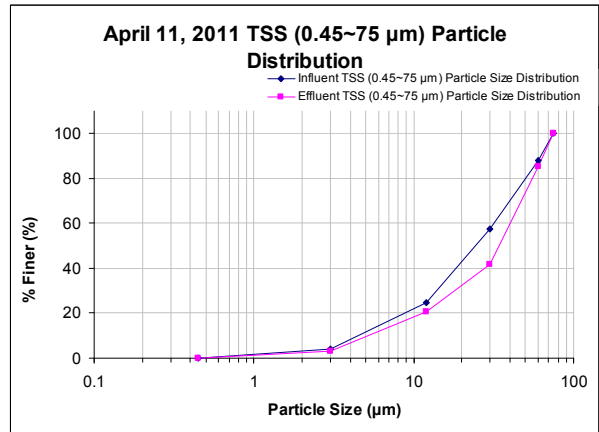
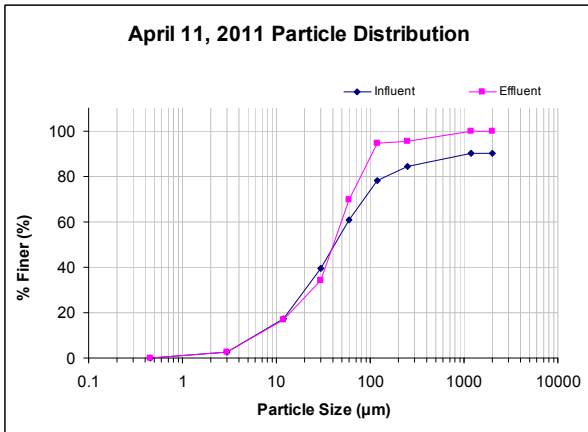

Appendix I.1: BamaBelle Full-Scale and SBIR II (pilot-scale) Performance for “Low” Flow Rate

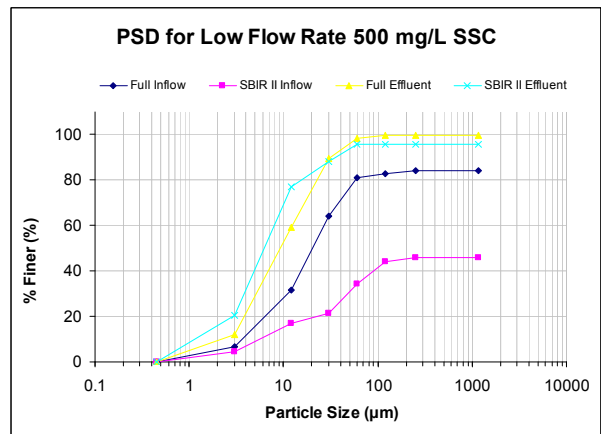
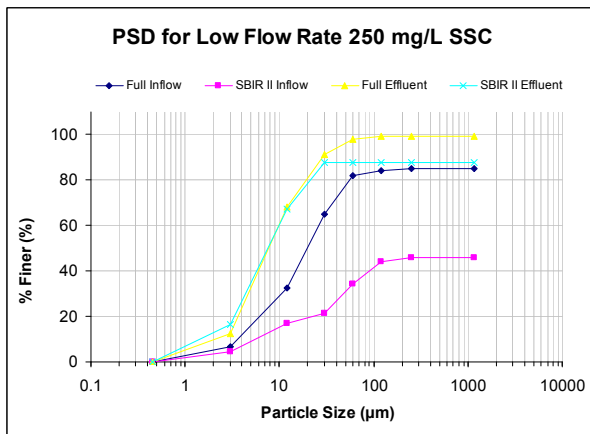
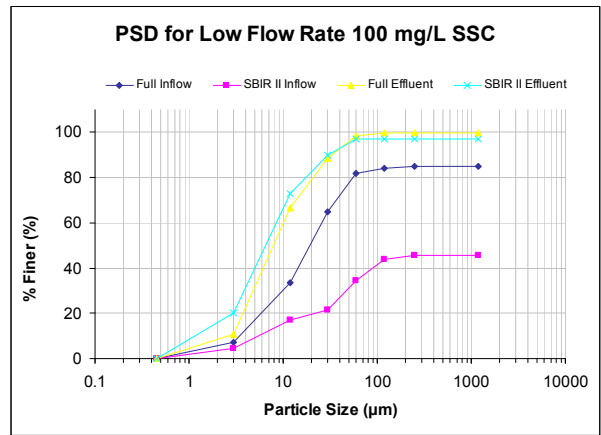
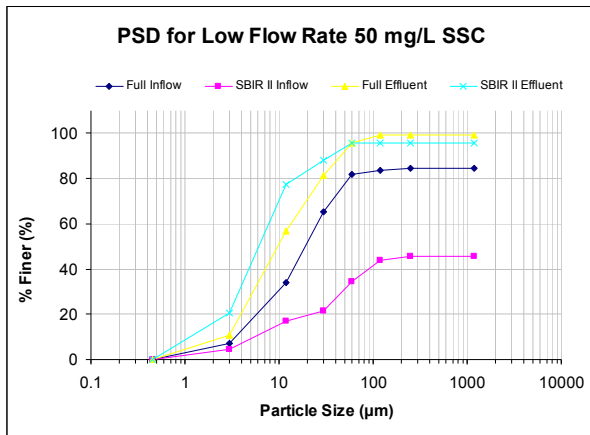

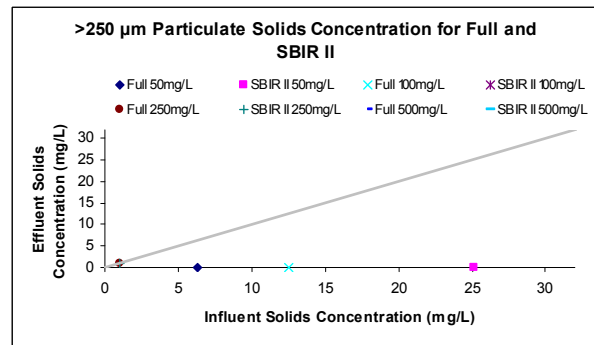
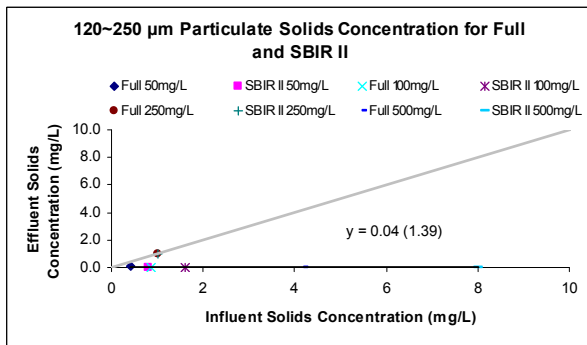
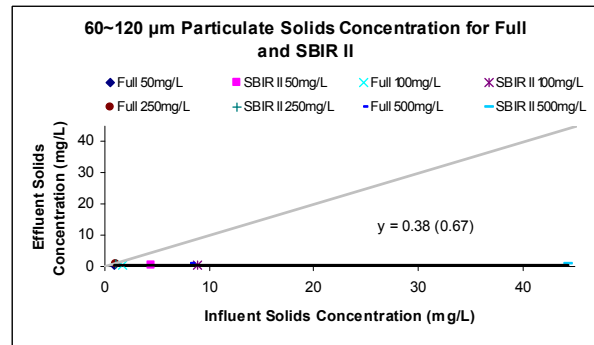
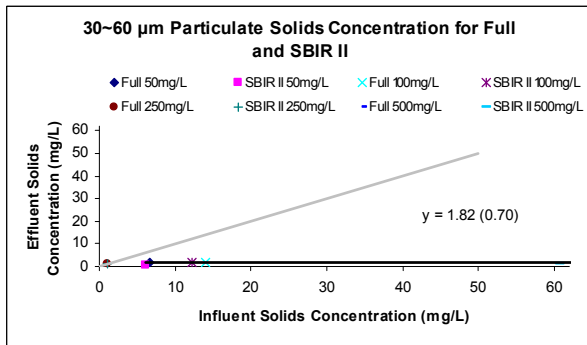
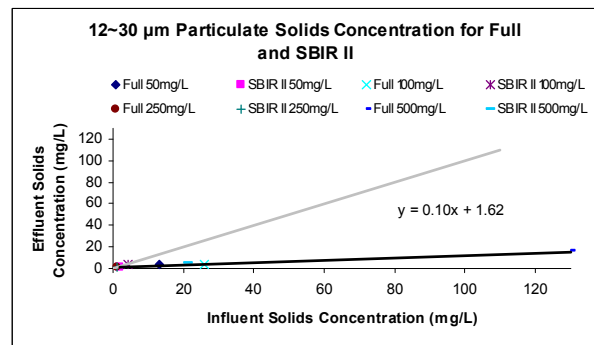
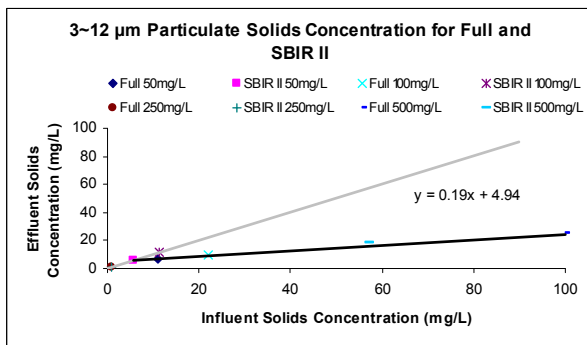
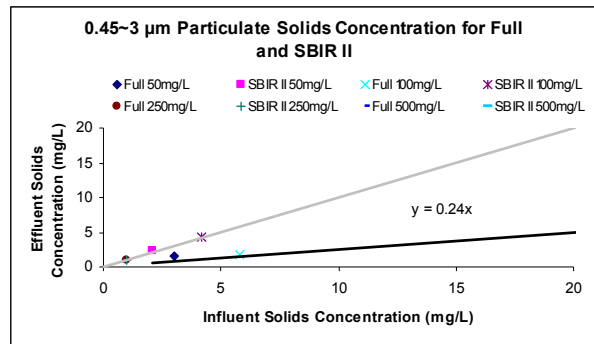
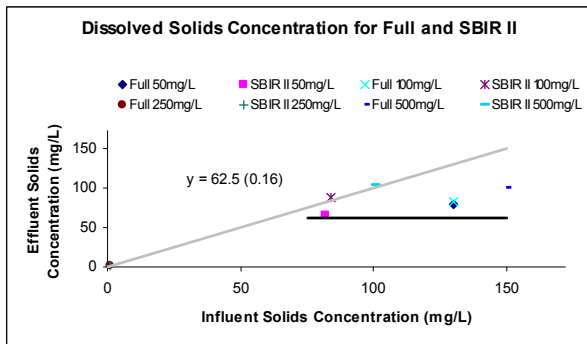

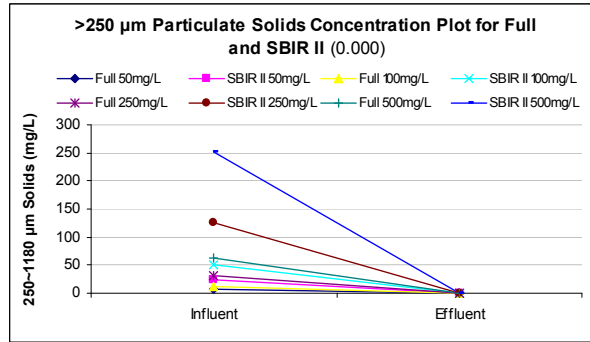
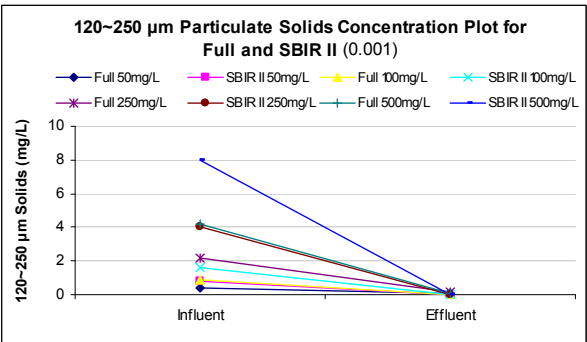
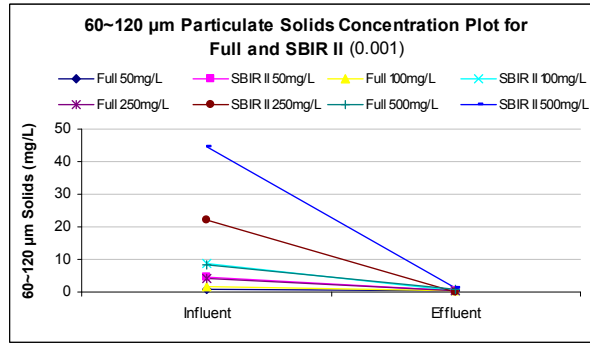
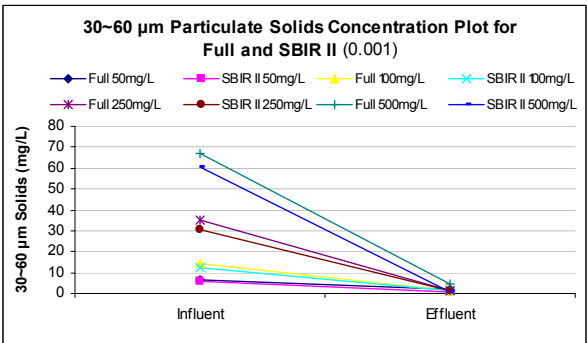
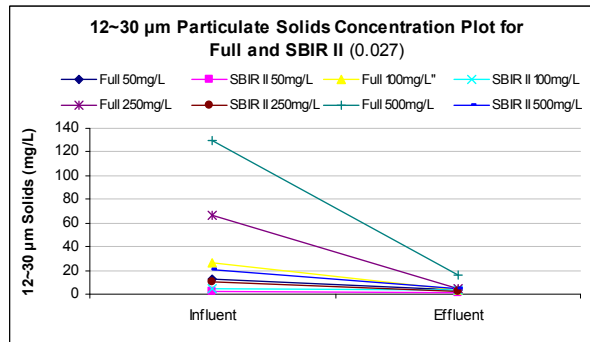
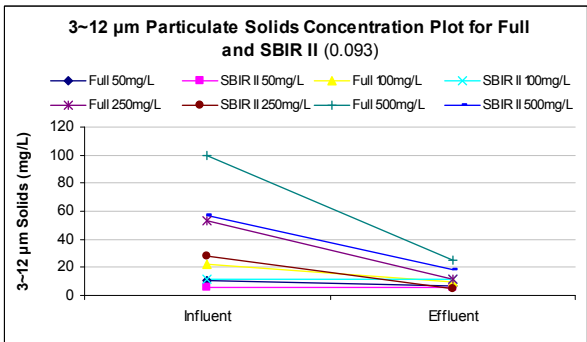
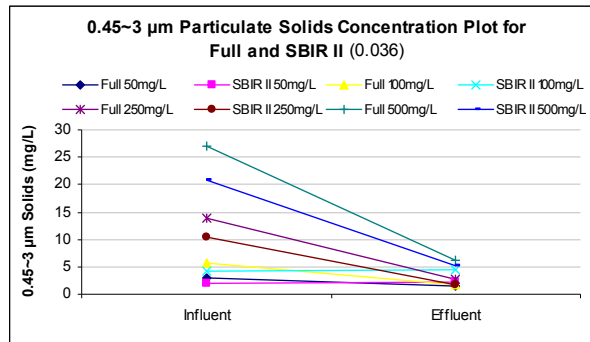
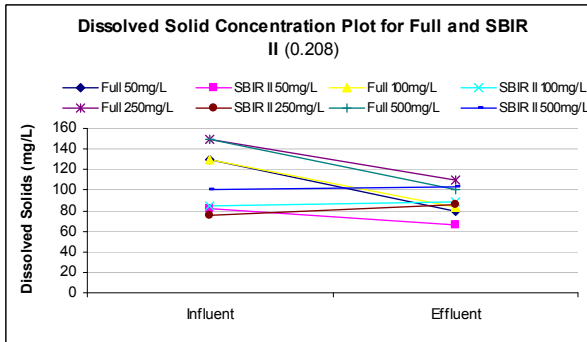

Appendix I.2: BamaBelle Full-Scale and SBIR II (pilot-scale) Performance for “Medium” Flow Rate

Rate

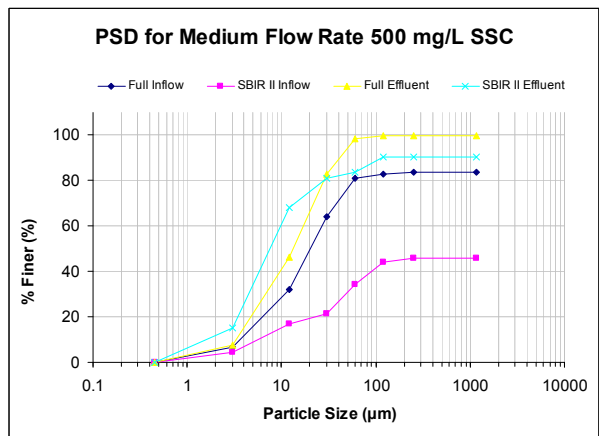
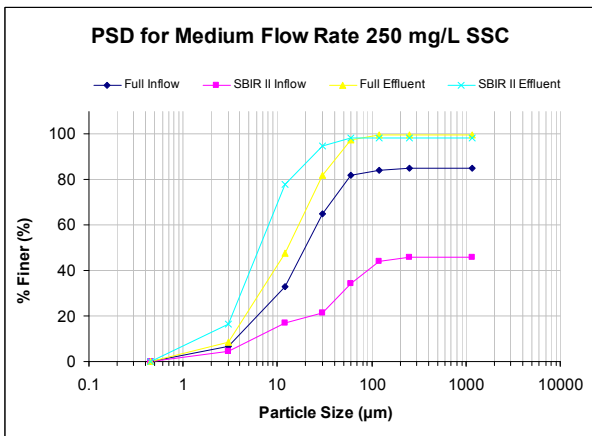
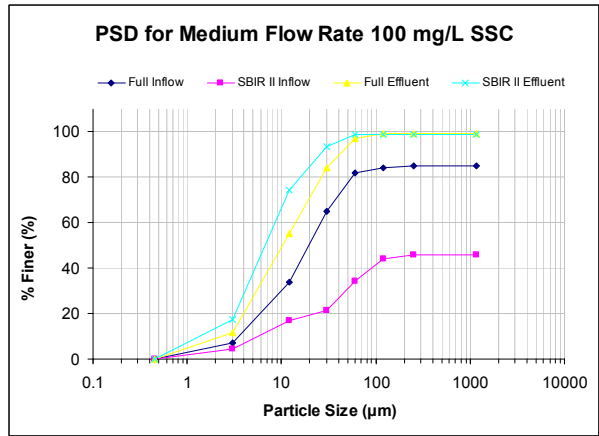
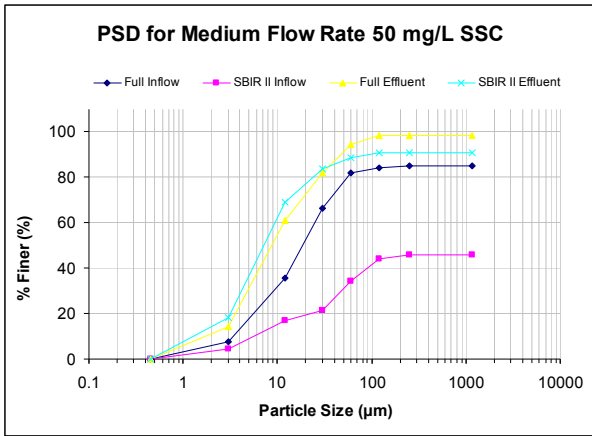

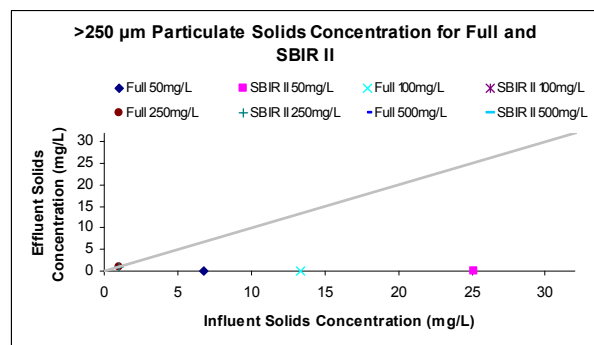
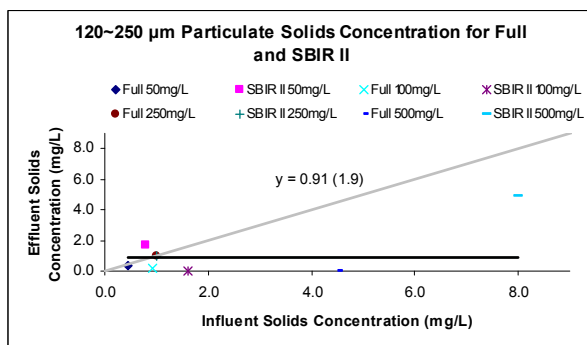
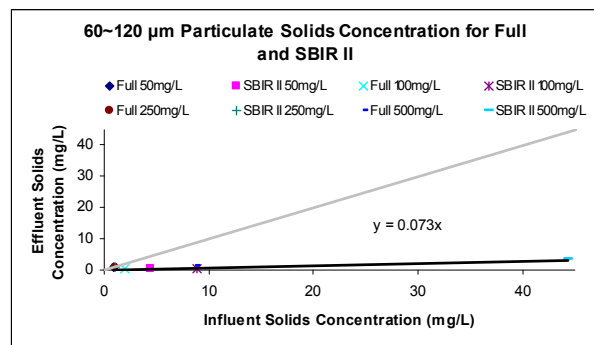
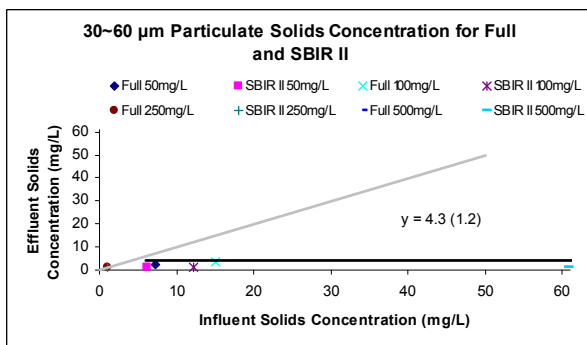
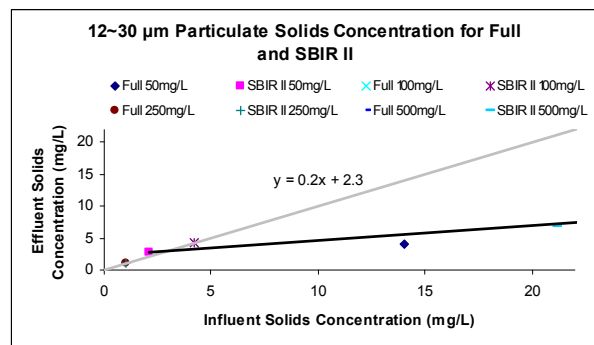
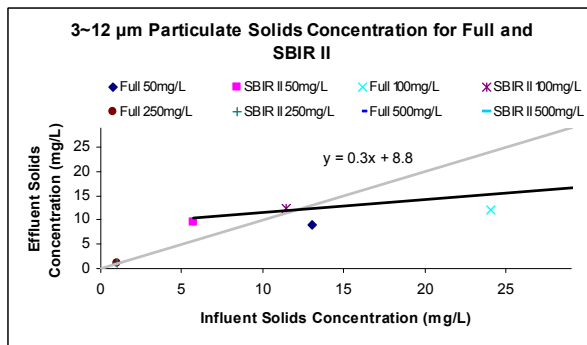
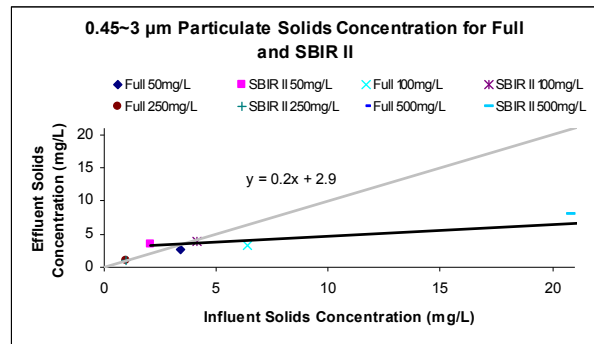
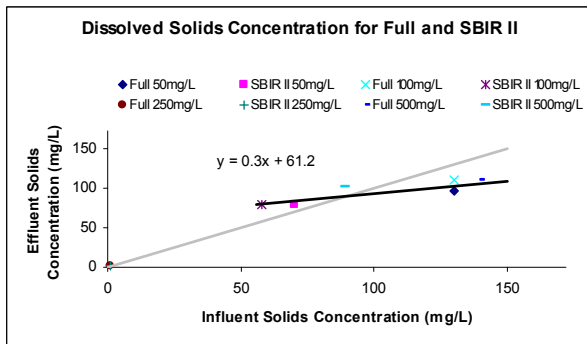

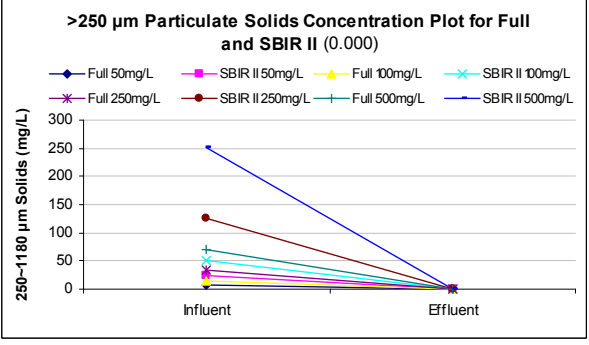
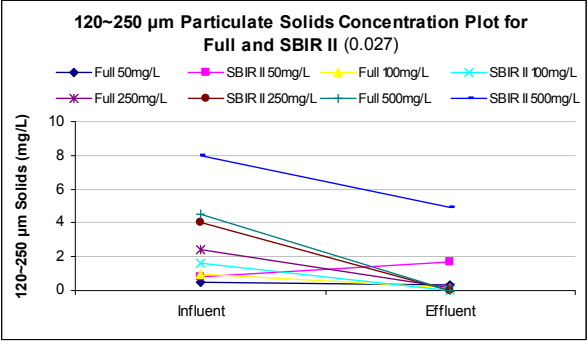
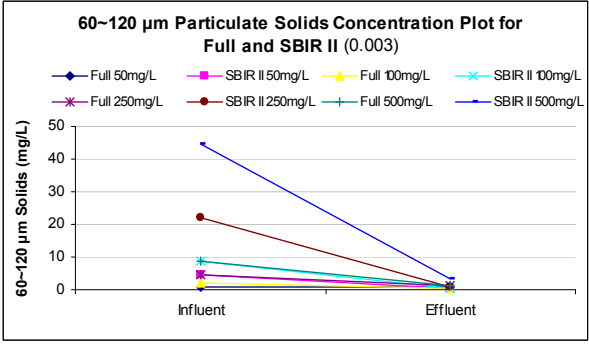
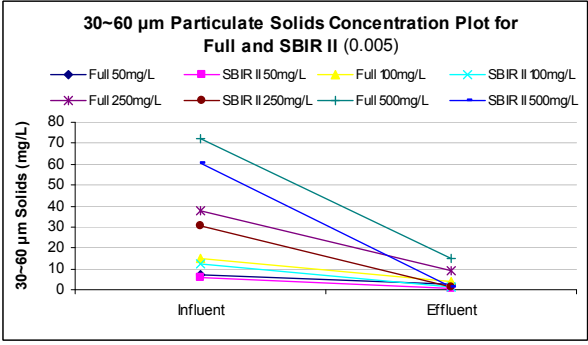
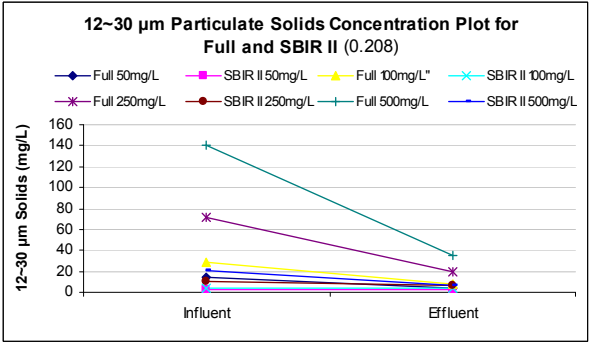
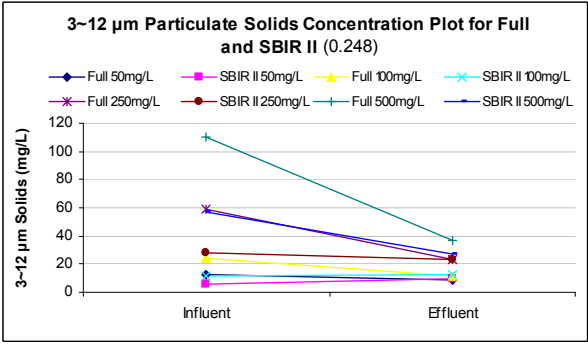
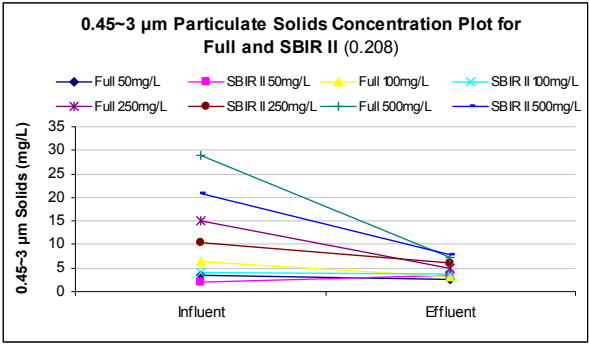
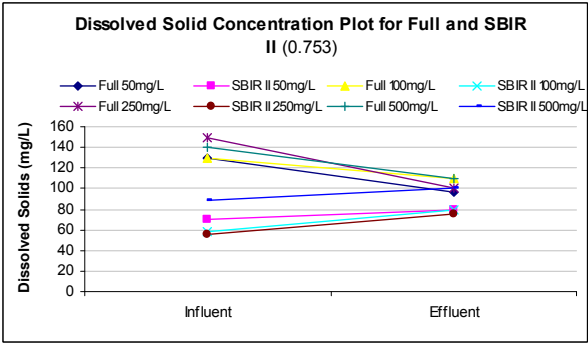

Appendix I.3: BamaBelle Full-Scale and SBIR II (pilot-scale) Performance for “High” Flow

Rate

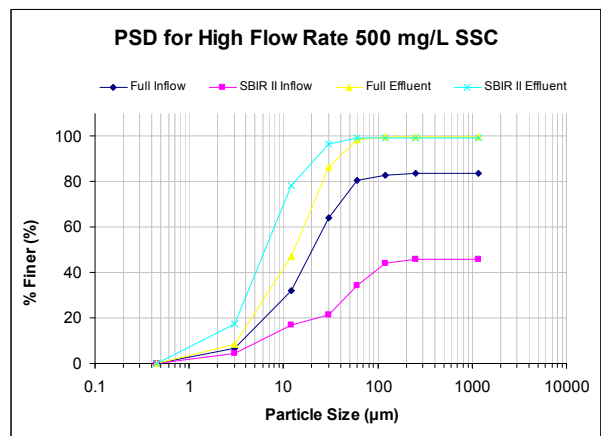
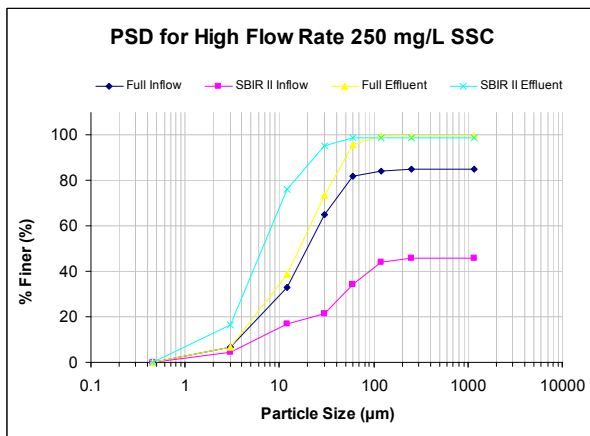
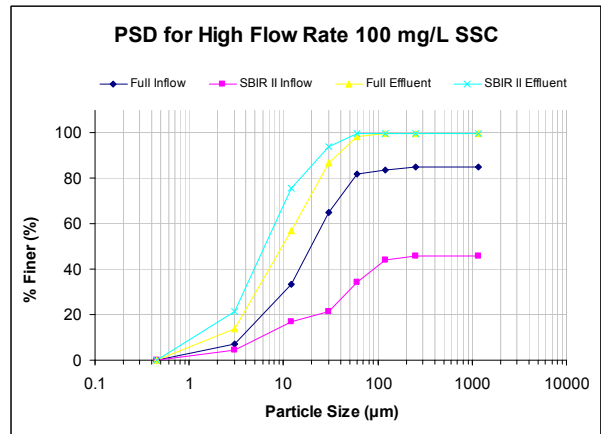
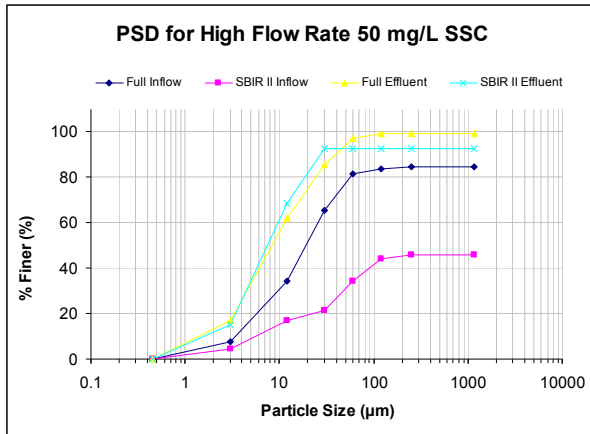

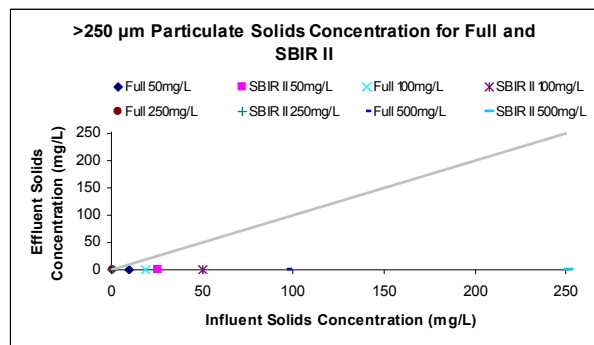
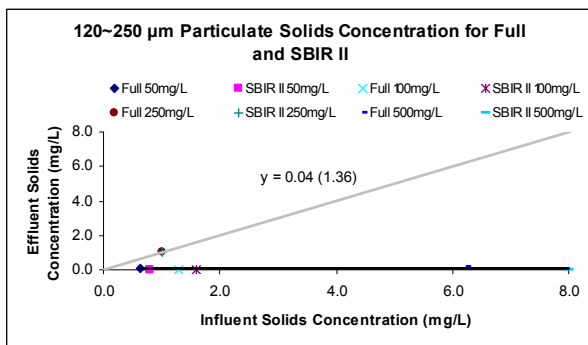
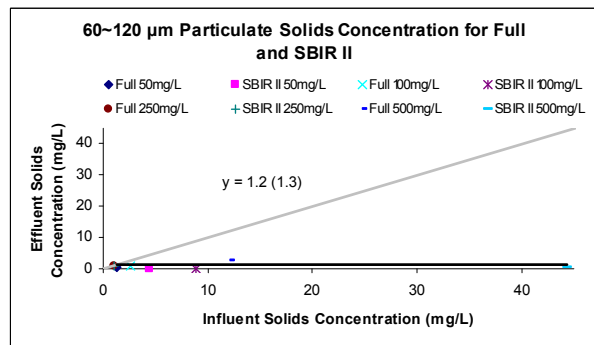
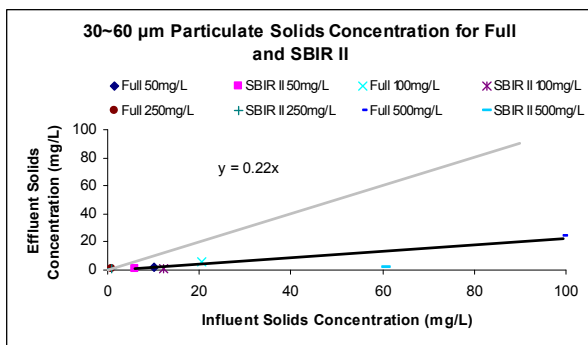
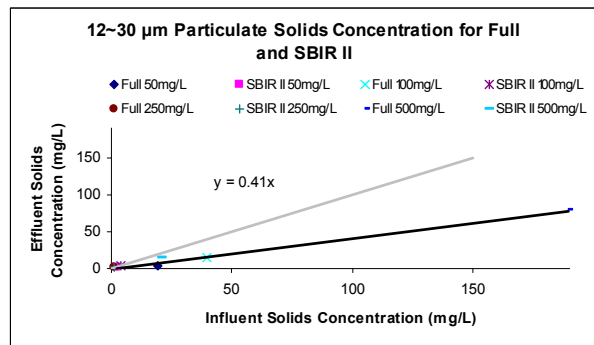
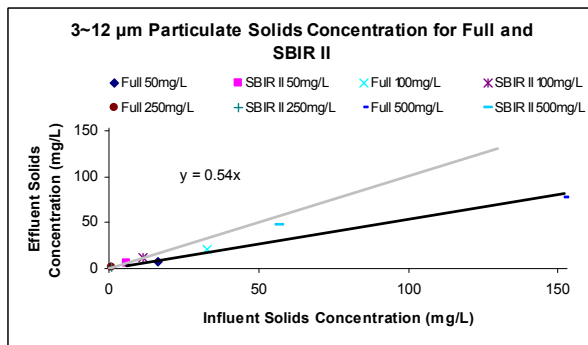
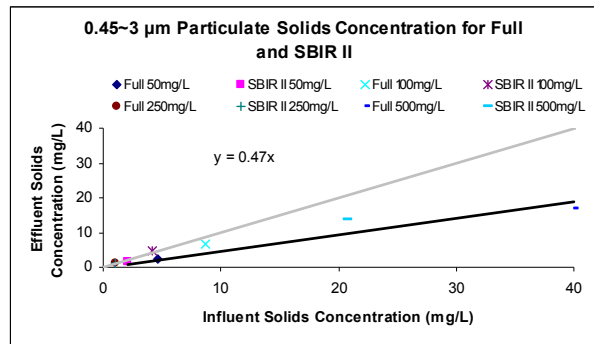
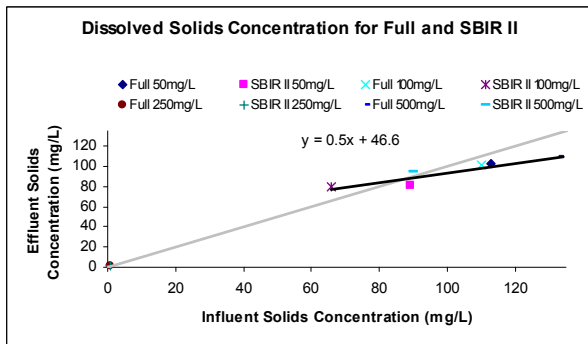

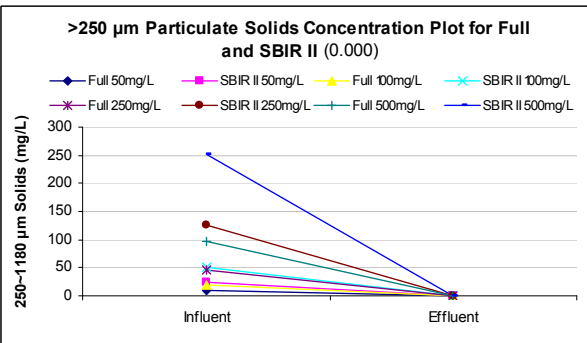
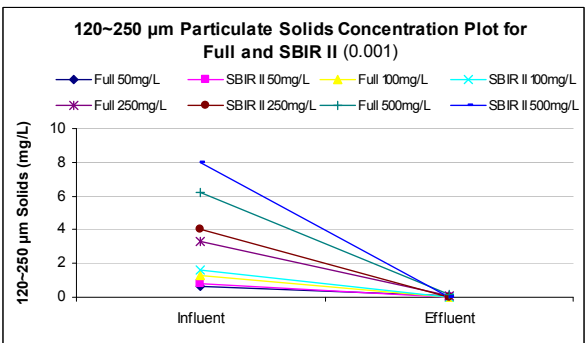
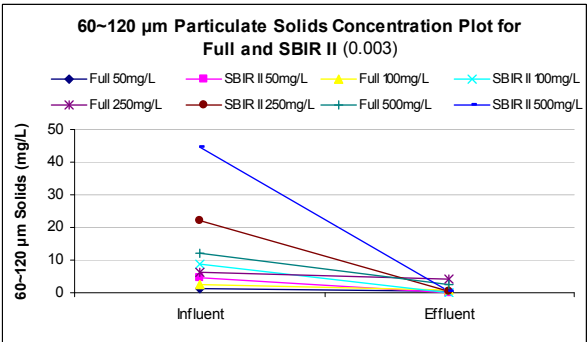
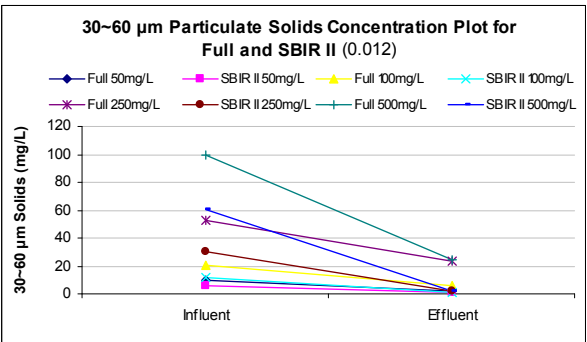
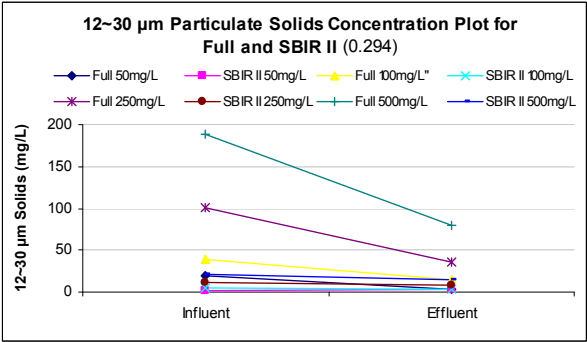
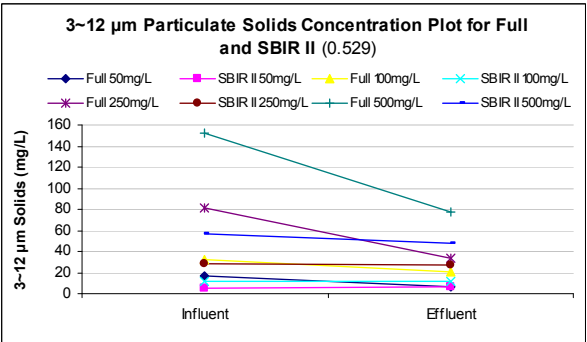
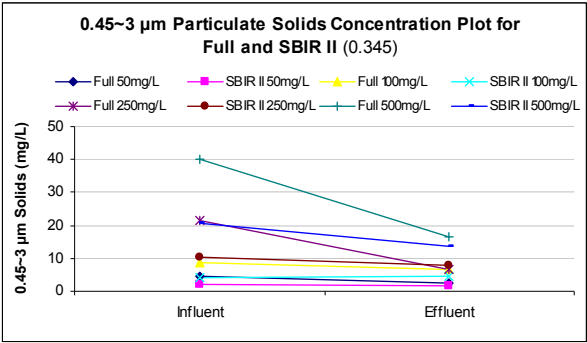
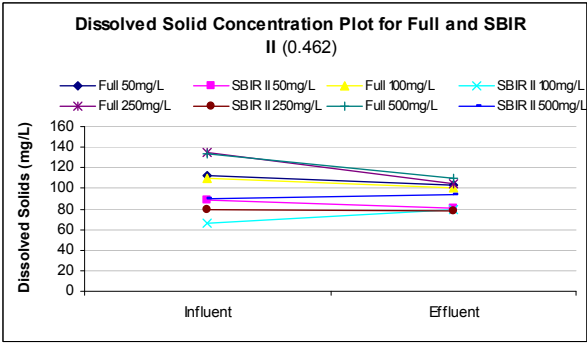

Appendix J: Logistic Regression Analysis for the TAPE Qualification

Binary Logistic Regression:

Link Function: Logit

Response Information

Variable	Value	Count	
Treatability	1	15	(Event)
	0	5	
Total		20	

Logistic Regression Table

Predictor	Coef	SE Coef	Z	P	Odds Ratio	95% CI
						Lower
Constant	8.96199	6.91679	1.30	0.195		
Subsamples	0.177843	0.254447	0.70	0.485	1.19	0.73
TAPE	-0.128005	2.77381	-0.05	0.963	0.88	0.00
SSC Influent (mg/L)	-0.0762556	0.0559159	-1.36	0.173	0.93	0.83
Reduction (%)	0.148406	0.111582	1.33	0.184	1.16	0.93
Peak Intensity (in/hr)	-3.41330	2.81263	-1.21	0.225	0.03	0.00
Duration (hr)	-2.13707	1.63982	-1.30	0.192	0.12	0.00

Predictor	Upper
Constant	
Subsamples	1.97
TAPE	202.08
SSC Influent (mg/L)	1.03
Reduction (%)	1.44
Peak Intensity (in/hr)	8.16
Duration (hr)	2.94

Log-Likelihood = -5.986

Test that all slopes are zero: G = 10.520, DF = 6, P-Value = 0.104

Goodness-of-Fit Tests

Method	Chi-Square	DF	P
Pearson	10.9642	13	0.614
Deviance	11.9729	13	0.530
Hosmer-Lemeshow	3.2508	8	0.918

Table of Observed and Expected Frequencies:

(See Hosmer-Lemeshow Test for the Pearson Chi-Square Statistic)

Value	Group										Total	
	1	2	3	4	5	6	7	8	9	10		
1												
Obs	0	1	2	1	1	2	2	2	2	2		15
Exp	0.1	0.9	1.3	1.4	1.6	1.8	2.0	2.0	2.0	2.0		
0												
Obs	2	1	0	1	1	0	0	0	0	0		5

Exp	1.9	1.1	0.7	0.6	0.4	0.2	0.0	0.0	0.0	0.0	
Total	2	2	2	2	2	2	2	2	2	2	20

Measures of Association:
 (Between the Response Variable and Predicted Probabilities)

Pairs	Number	Percent	Summary Measures	
Concordant	66	88.0	Somers' D	0.76
Discordant	9	12.0	Goodman-Kruskal Gamma	0.76
Ties	0	0.0	Kendall's Tau-a	0.30
Total	75	100.0		